

Technical Publications

**DOC2238423
Revision 06**

OEC ELITE DICOM CONFORMANCE STATEMENT

Copyright© 2016-2022 by GE HealthCare Co.

Do not duplicate

THIS PAGE LEFT INTENTIONALLY BLANK

CONFORMANCE STATEMENT OVERVIEW

OEC Elite is a system used to assist trained surgeons. The system provides X-ray images while the surgeon performs a medical procedure. Images from the system help the surgeon to visualize the patients' anatomy to localize surgical regions of interest and pathology.

The content is consistent with the 2016c and 2018c version of the DICOM Standard.

The content covers all versions/models of OEC Elite to date, some functionality may not be present because of the Option selected or if the motorized version of the product is selected. This content is a superset of all Models and Options of the OEC Elite.

The system uses the DICOM protocol to send images to printers and PACS servers and to receive worklists of scheduled exams from the HIS (Hospital Information System), RIS (Radiology Information System), or PACS (Picture Archive Communications Server).

Table 0.1 provides an overview of the network services supported by GEHC OEC ELITE.

Table 0.1 – NETWORK SERVICES

SOP Classes	User of Service (SCU)	Provider of Service (SCP)
Transfer		
Computed Radiography Image Storage	Yes	Yes
Digital X-Ray Image Storage – For Presentation	No	Yes
Digital X-Ray Image Storage – For Processing	No	Yes
Digital Mammography X-Ray Image Storage – For Presentation	No	Yes
Digital Mammography X-Ray Image Storage – For Processing	No	Yes
CT Image Storage	No	Yes
Ultrasound Multi-frame Image Storage	No	Yes
MR Image Storage	No	Yes
Ultrasound Image Storage	No	Yes
Secondary Capture Image Storage	Yes	Yes
Multi-frame Grayscale Byte SC	Yes	Yes
X-Ray Angiographic Image Storage	Yes	Yes
X-Ray Radiofluoroscopic Image Storage	Yes	Yes
Nuclear Medicine Image Storage	No	Yes
X-Ray Radiation Dose SR	Yes	No
Positron Emission Tomography Image Storage	No	Yes
RT Image Storage	No	Yes
Query/Retrieve		
Patient Root Query/Retrieve Information Model – FIND	Yes	No
Patient Root Query/Retrieve Information Model – MOVE	Yes	No

SOP Classes	User of Service (SCU)	Provider of Service (SCP)
Study Root Query/Retrieve Information Model – FIND	Yes	No
Study Root Query/Retrieve Information Model – MOVE	Yes	No
Print Management		
Basic Film Session SOP Class	Yes	No
Basic Film Box SOP Class	Yes	No
Basic Grayscale Image Box SOP Class	Yes	No
Basic Grayscale Print Management Meta SOP Class	Yes	No
Printer SOP Class	Yes	No
Presentation LUT SOP Class	Yes	No
Workflow Management		
Storage Commitment Push Model SOP Class	Yes	No
Modality Performed Procedure Step SOP Class	Yes	No
Modality Performed Procedure Step Retrieve SOP Class	No	No
Modality Worklist Information Model – FIND SOP Class	Yes	No

Table 0.2 provides an overview of the Media Storage Application Profiles supported by OEC ELITE.

Table 0.2 – MEDIA SUPPORT

Media Storage Application Profile	Write Files (FSC or FSU)	Read Files (FSR)
USB		
Raw Data Storage	Yes	Yes
Computed Radiography Image Storage	Yes	Yes
Digital X-Ray Image Storage – For Presentation	No	Yes
Digital X-Ray Image Storage – For Processing	No	Yes
Digital Mammography X-Ray Image Storage – For Presentation	No	Yes
Digital Mammography X-Ray Image Storage – For Processing	No	Yes
CT Image Storage	No	Yes
Ultrasound Multi-frame Image Storage	No	Yes
MR Image Storage	No	Yes
Ultrasound Image Storage	No	Yes
Secondary Capture Image Storage	Yes	Yes
Multi-frame Grayscale Byte SC	Yes	Yes
X-Ray Angiographic Image Storage	Yes	Yes
X-Ray Radiofluoroscopic Image Storage	Yes	Yes
Nuclear Medicine Image Storage	No	Yes
X-Ray Radiation Dose SR	Yes	No

Media Storage Application Profile	Write Files (FSC or FSU)	Read Files (FSR)
Positron Emission Tomography Image Storage	No	Yes
RT Image Storage	No	Yes

REVISION HISTORY

Revision	Author	Date	Description
1	Brett C. Anderson	19 April 2019	Initial release using 1.1 DICOM Template
2	Brett C. Anderson	30 September 2019	Clarification to also indicate conformance to prior DICOM standard 2016c
3	Mahy Hussain	20 April 2020	Updated information regarding Secure option package
4	Mahy Hussain	29 May 2020	Updated TLS ciphers
5	Laura Bentivegna	13 April 2023	Remove Radiation Dose Module from MPPS Updated company name
6	Laura Bentivegna	See MyWorkshop	Clarify what SOP Classes cannot be generated Add information that system has a single network interface Update DICOM Tag (0018,1164) description to clarify that it does not adjust due to magnification or geometric calibration

THIS PAGE LEFT INTENTIONALLY BLANK

TABLE OF CONTENTS

1. INTRODUCTION..... 12

1.1 Overview 12

1.2 Overall DICOM Conformance Statement Document Structure..... 14

1.3 Intended Audience 15

1.4 Scope and Field of Application..... 15

1.5 Important Remarks 15

1.6 References 16

1.7 Definitions 16

1.8 Symbols and Abbreviations..... 18

2. NETWORK CONFORMANCE STATEMENT21

2.1 Introduction 21

2.2 Implementation Model 22

2.3 AE Specifications 24

2.4 Communication Profiles 48

2.5 Extensions / Specializations/ Privatizations 49

2.6 Configuration 49

2.7 Support of Extended Character Sets 51

2.8 Codes and Controlled Terminology 51

2.9 Security Profiles 51

3. MEDIA STORAGE CONFORMANCE STATEMENT53

3.1 Introduction 53

3.2 Implementation Model 53

3.3 AE Specifications 55

3.4 Augmented and Private Application Profiles 58

3.5	Extensions / Specializations / Privatizations.....	58
3.6	Configuration	60
3.7	Support of Extended Character Sets	60
4.	X-RAY ANGIOGRAPHIC INFORMATION OBJECT IMPLEMENTATION	61
4.1	Introduction	61
4.2	OEC Elite Mapping of DICOM Entities	61
4.3	IOD Module Table	61
4.4	Information Module Definitions	63
4.5	Standard Extended and Private Data Attributes	75
4.6	Standard Extended and Private Context Groups	75
5.	X-RAY RF INFORMATION OBJECT IMPLEMENTATION.....	76
5.1	Introduction	76
5.2	OEC Elite Mapping of DICOM Entities	76
5.3	IOD Module Table	76
5.4	Information Module Definitions	77
5.5	Standard Extended and Private Data Attributes	79
5.6	Standard Extended and Private Context Groups	79
6.	CR INFORMATION OBJECT IMPLEMENTATION	80
6.1	Introduction	80
6.2	OEC Elite Mapping of DICOM Entities	80
6.3	IOD Module Table	80
6.4	Information Module Definitions	81
6.5	Standard Extended and Private Data Attributes	84
6.6	Standard Extended and Private Context Groups	87
7.	SECONDARY CAPTURE INFORMATION OBJECT IMPLEMENTATION.....	88
7.1	Introduction	88
7.2	OEC Elite Mapping of DICOM Entities	88

7.3	IOD Module Table	88
7.4	Information Module Definitions	89
7.5	Standard Extended and Private Data Attributes	90
7.6	Standard Extended and Private Context Groups	90
8.	MULTI-FRAME GRAYSCALE BYTE SC INFORMATION OBJECT IMPLEMENTATION	91
8.1	Introduction	91
8.2	OEC Elite Mapping of DICOM Entities	91
8.3	IOD Module Table	91
8.4	Information Module Definitions	92
8.5	Standard Extended and Private Data Attributes	93
8.6	Standard Extended and Private Context Groups	93
9.	X-RAY RADIATION DOSE STRUCTURED REPORT INFORMATION OBJECT IMPLEMENTATION	94
9.1	Introduction	94
9.2	OEC Elite Mapping of DICOM Entities	94
9.3	IOD Module Table	94
9.4	Information Module Definitions	95
9.5	Standard Extended and Private Data Attributes	99
9.6	Standard Extended and Private Context Groups	99
9.7	Standard, Standard Extended and Private Templates	99
10.	MODALITY WORKLIST QUERY IMPLEMENTATION	109
10.1	Introduction	109
10.2	OEC Elite Mapping of DICOM Entities	109
10.3	Worklist Query Module Table.....	109
10.4	Worklist Query Module Definitions	110
11.	MODALITY PERFORMED PROCEDURE STEP IMPLEMENTATION	116
11.1	Introduction	116

11.2	Relationship between Scheduled and Performed Procedure Steps.....	116
11.3	Modality Performed Procedure Step Module Table	116
11.4	Modality Performed Procedure Step Module Definitions	116
12.	STORAGE COMMITMENT PUSH MODEL IMPLEMENTATION.....	122
12.1	Storage Commitment Push Model Information Object Definition	122
13.	BASIC DIRECTORY INFORMATION OBJECT IMPLEMENTATION	124
13.1	IOD Module Table	124
13.2	Information Module Definitions	124
13.3	Private Data Dictionary	129
14.	PRINT MANAGEMENT IMPLEMENTATION	130
14.1	Introduction	130
14.2	Basic Film Session SOP Class.....	130
14.3	Basic Film Box SOP Class.....	131
14.4	Basic Grayscale Image Box SOP Class.....	133
14.5	Printer SOP Class.....	134
14.6	Presentation LUT SOP Class	135
15.	QUERY IMPLEMENTATION	136
15.1	OEC Elite Mapping of DICOM Entities	136
15.2	Information Model Keys	136
15.3	Private Data Attributes.....	140

1. INTRODUCTION

1.1 OVERVIEW

This DICOM Conformance Statement is divided into Sections as described below:

Section 1 (Introduction), which describes the overall structure, intent, and references for this Conformance Statement

Section 2 (Network Conformance Statement), which specifies the GEHC equipment compliance to the DICOM requirements for the implementation of Networking features.

Section 3 (Media Storage Conformance Statement), which specifies the GEHC equipment compliance to the DICOM requirements for the implementation of Media Storage features.

Section 4 (XA Information Object Implementations), which specifies the GEHC equipment compliance to DICOM requirements for the implementation of an X-Ray Angiography Information Object. Also covers common modules for RF, SC and CR).

Section 5 (RF Information Object Implementations), which specifies the GEHC equipment compliance to DICOM requirements for the implementation of an X-Ray Radio fluoroscopy Information Object.

Section 6 (SC Information Object Implementation), which specifies the GEHC equipment compliance to DICOM requirements for the implementation of a Secondary Capture and Multi-frame Grayscale Byte Secondary Capture Image Information Objects.

Section 7 (CR Information Object Implementation), which specifies the GEHC equipment compliance to DICOM requirements for the implementation of a Computed Radiography Image Information Object.

Section 8 (Multi-frame Grayscale Byte SC Information Object Implementation), which specifies the GEHC equipment compliance to DICOM requirements for the implementation of a Multi-frame Grayscale Byte SC Image Information Object.

Section 9 (X-Ray RDSR Information Object Implementation), which specifies the GEHC equipment compliance to DICOM requirements for the implementation of a X-Ray Radiation Dose SR Information Object.

Section 10 (Modality Worklist Information Model), which specifies the GEHC equipment compliance to DICOM requirements for the implementation of the Modality Worklist service.

Section 11 (Storage Commitment Push Model Implementation), which specifies the GEHC equipment compliance to DICOM requirements for the implementation of the Storage Commitment Push Model SOP Class.

Section 12 (Basic Directory Information Object Implementation), which specifies the GEHC equipment compliance to DICOM requirements for the implementation of a Basic Directory Information Object.

Section 13 (Basic Print Meta SOP Class Information Model), which specifies the GEHC equipment compliance to DICOM requirements for the implementation of the Basic Print Meta SOP Classes (Grayscale).

Section 14 (Patient and Study Root Query/Retrieve Information Model), which specifies the GEHC equipment compliance to DICOM requirements for the implementation of the Patient and Study Root Query/Retrieve service.

Section 15 (Modality Perform Procedure Step - MPPS), which specifies the GEHC equipment compliance to DICOM requirements for the implementation of the Modality Perform Procedure Step service.

1.2 OVERALL DICOM CONFORMANCE STATEMENT DOCUMENT STRUCTURE

The Documentation Structure of the GEHC DICOM Conformance Statements is shown in the Illustration below.

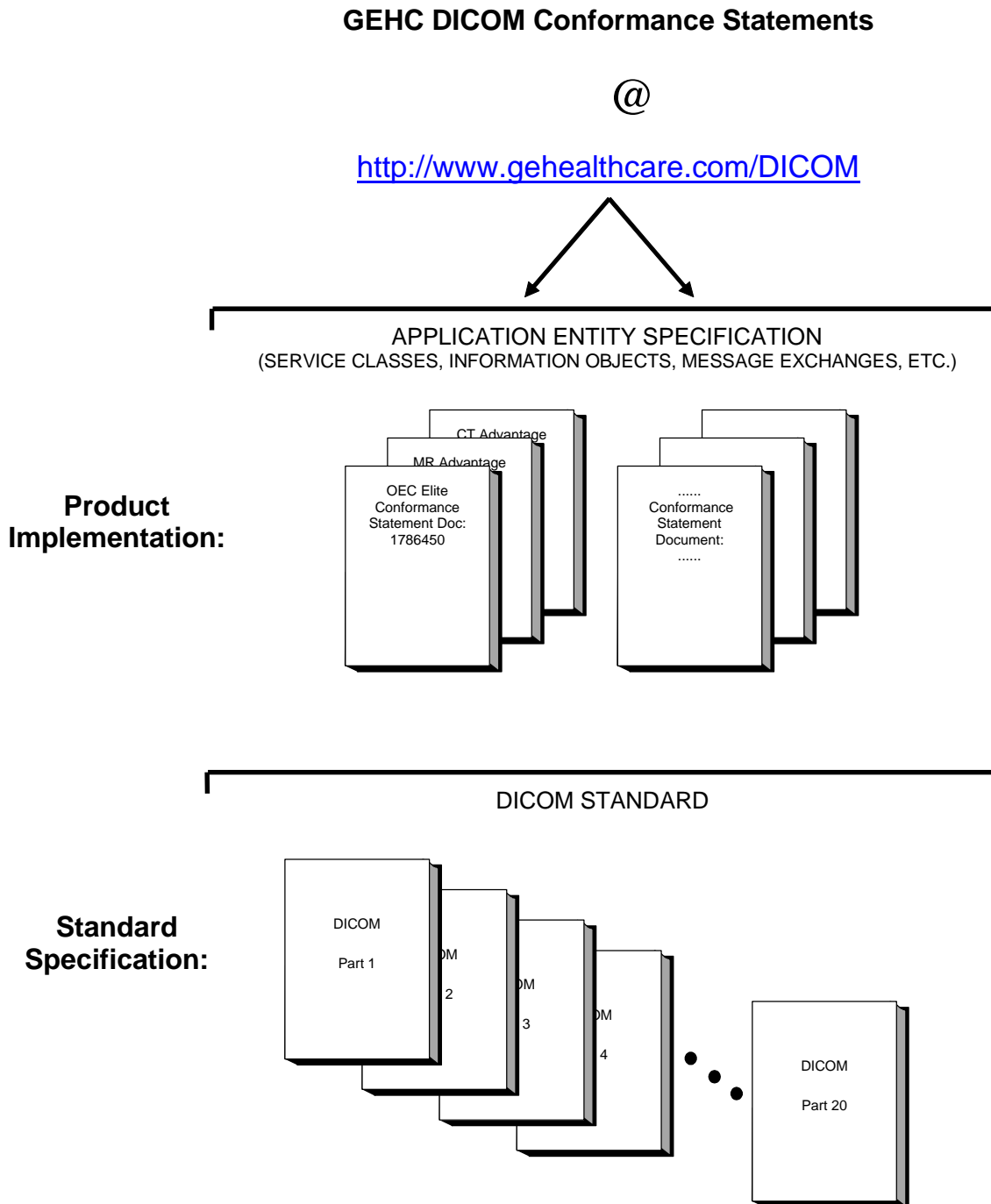

This DICOM Conformance Statement documents the DICOM Conformance Statement and Technical Specification required to interoperate with the GEHC network interface.

The GEHC Conformance Statement, contained in this document, also specifies the Lower Layer communications which it supports (e.g., TCP/IP). However, the Technical Specifications are defined in the DICOM Part 8 standard.

For more information regarding DICOM, copies of the Standard may be obtained on the Internet at <http://medical.nema.org>. Comments on the Standard may be addressed to:

DICOM Secretariat
NEMA
1300 N. 17th Street, Suite 1752
Rosslyn, VA 22209
USA
Phone: +1.703.841.3200

1.3 INTENDED AUDIENCE

The reader of this document is concerned with software design and/or system integration issues. It is assumed that the reader of this document is familiar with the DICOM Standard and with the terminology and concepts which are used in that Standard.

1.4 SCOPE AND FIELD OF APPLICATION

It is the intent of this document to provide an unambiguous specification for GEHC implementations. This specification, called a Conformance Statement, includes a DICOM Conformance Statement and is necessary to ensure proper processing and interpretation of GEHC medical data exchanged using DICOM. The GEHC Conformance Statements are available to the public.

The reader of this DICOM Conformance Statement should be aware that different GEHC devices are capable of using different Information Object Definitions. For example, a GEHC CT Scanner may send images using the CT Information Object, MR Information Object, Secondary Capture Object, etc.

Included in this DICOM Conformance Statement are the Module Definitions which define all data elements used by this GEHC implementation. If the user encounters unspecified private data elements while parsing a GEHC Data Set, the user is well advised to ignore those data elements (per the DICOM standard). Unspecified private data element information is subject to change without notice. If, however, the device is acting as a "full fidelity storage device", it should retain and re-transmit all of the private data elements which are sent by GEHC devices.

1.5 IMPORTANT REMARKS

The use of these DICOM Conformance Statements, in conjunction with the DICOM Standards, is intended to facilitate communication with GEHC imaging equipment. However, **by itself, it is not sufficient to ensure that inter-operation will be successful.** The **user (or user's agent)** needs to proceed with caution and address at least four issues:

- **Integration** - The integration of any device into an overall system of interconnected devices goes beyond the scope of standards (DICOM v3.0), and of this introduction and associated DICOM Conformance Statements when interoperability with non-GEHC equipment is desired. The responsibility to analyze the applications requirements and to design a solution that integrates GEHC imaging equipment with non-GEHC systems is the **user's** responsibility and should not be underestimated. The **user** is strongly advised to ensure that such an integration analysis is correctly performed.

- **Validation** - Testing the complete range of possible interactions between any GEHC device and non-GEHC devices, before the connection is declared operational, should not be overlooked. Therefore, the **user** should ensure that any non-GEHC provider accepts full responsibility for all validation required for their connection with GEHC devices. This includes the accuracy of the image data once it has crossed the interface between the GEHC imaging equipment and the non-GEHC device and the stability of the image data for the intended applications.

Such a validation is required before any clinical use (diagnosis and/or treatment) is performed. It applies when images acquired on GEHC imaging equipment are processed/displayed on a non-GEHC device, as well as when images acquired on non-GEHC equipment is processed/displayed on a GEHC console or workstation.

- **Future Evolution** - GEHC understands that the DICOM Standard will evolve to meet the user's growing requirements. GEHC is actively involved in the development of the DICOM Standard. DICOM will incorporate new features and technologies and GEHC may follow the evolution of the Standard. The GEHC protocol is based on DICOM as specified in each DICOM Conformance Statement. Evolution of the Standard may require changes to devices which have implemented DICOM. **In addition, GEHC reserves the right to discontinue or make changes to the support of communications features (on its products) described by these DICOM Conformance Statements.** The **user** should ensure that any non-GEHC provider, which connects with GEHC devices, also plans for the future evolution of the DICOM Standard. Failure to do so will likely result in the loss of function and/or connectivity as the DICOM Standard changes and GEHC Products are enhanced to support these changes.
- **Interaction** - It is the sole responsibility of the **non-GEHC provider** to ensure that communication with the interfaced equipment does not cause degradation of GEHC imaging equipment performance and/or function.

1.6 REFERENCES

NEMA PS3 Digital Imaging and Communications in Medicine (DICOM) Standard, available free at <http://medical.nema.org/>

1.7 DEFINITIONS

Informal definitions are provided for the following terms used in this Conformance Statement. The DICOM Standard is the authoritative source for formal definitions of these terms.

Abstract Syntax – the information agreed to be exchanged between applications, generally equivalent to a Service/Object Pair (SOP) Class. Examples : Verification SOP Class, Modality Worklist Information Model Find SOP Class, Computed Radiography Image Storage SOP Class.

Application Entity (AE) – an end point of a DICOM information exchange, including the DICOM network or media interface software; i.e., the software that sends or receives DICOM information objects or messages. A single device may have multiple Application Entities.

Application Entity Title – the externally known name of an *Application Entity*, used to identify a DICOM application to other DICOM applications on the network.

Application Context – the specification of the type of communication used between *Application Entities*. Example: DICOM network protocol.

Association – a network communication channel set up between *Application Entities*.

Attribute – a unit of information in an object definition; a data element identified by a *tag*. The information may be a complex data structure (Sequence), itself composed of lower level data elements. Examples: Patient ID (0010,0020), Accession Number (0008,0050), Photometric Interpretation (0028,0004), Procedure Code Sequence (0008,1032).

Information Object Definition (IOD) – the specified set of *Attributes* that comprise a type of data object; does not represent a specific instance of the data object, but rather a class of similar data objects that have the same properties. The *Attributes* may be specified as Mandatory (Type 1), Required but possibly unknown (Type 2), or Optional (Type 3), and there may be conditions associated with the use of an Attribute (Types 1C and 2C). Examples: MR Image IOD, CT Image IOD, Print Job IOD.

Joint Photographic Experts Group (JPEG) – a set of standardized image compression techniques, available for use by DICOM applications.

Media Application Profile – the specification of DICOM information objects and encoding exchanged on removable media (e.g., CDs)

Module – a set of *Attributes* within an *Information Object Definition* that are logically related to each other. Example: Patient Module includes Patient Name, Patient ID, Patient Birth Date, and Patient Sex.

Negotiation – first phase of *Association* establishment that allows *Application Entities* to agree on the types of data to be exchanged and how that data will be encoded.

Presentation Context – the set of DICOM network services used over an *Association*, as negotiated between *Application Entities*; includes *Abstract Syntaxes* and *Transfer Syntaxes*.

Protocol Data Unit (PDU) – a packet (piece) of a DICOM message sent across the network. Devices must specify the maximum size packet they can receive for DICOM messages.

Security Profile – a set of mechanisms, such as encryption, user authentication, or digital signatures, used by an *Application Entity* to ensure confidentiality, integrity, and/or availability of exchanged DICOM data

Service Class Provider (SCP) – role of an *Application Entity* that provides a DICOM network service; typically, a server that performs operations requested by another *Application Entity* (*Service Class User*). Examples: Picture Archiving and Communication System (image storage SCP, and image query/retrieve SCP), Radiology Information System (modality worklist SCP).

Service Class User (SCU) – role of an *Application Entity* that uses a DICOM network service; typically, a client. Examples: imaging modality (image storage SCU, and modality worklist SCU), imaging workstation (image query/retrieve SCU)

Service/Object Pair (SOP) Class – the specification of the network or media transfer (service) of a particular type of data (object); the fundamental unit of DICOM interoperability specification. Examples: Ultrasound Image Storage Service, Basic Grayscale Print Management.

Service/Object Pair (SOP) Instance – an information object; a specific occurrence of information exchanged in a *SOP Class*. Examples: a specific x-ray image.

Tag – a 32-bit identifier for a data element, represented as a pair of four digit hexadecimal numbers, the “group” and the “element”. If the “group” number is odd, the tag is for a private (manufacturer-specific) data element. Examples: (0010,0020) [Patient ID], (07FE,0010) [Pixel Data], (0019,0210) [private data element]

Transfer Syntax – the encoding used for exchange of DICOM information objects and messages. Examples: *JPEG* compressed (images), little endian explicit value representation.

Unique Identifier (UID) – a globally unique “dotted decimal” string that identifies a specific object or a class of objects; an ISO-8824 Object Identifier. Examples: Study Instance UID, SOP Class UID, SOP Instance UID.

Value Representation (VR) – the format type of an individual DICOM data element, such as text, an integer, a person’s name, or a code. DICOM information objects can be transmitted with either explicit identification of the type of each data element (Explicit VR), or without explicit identification (Implicit VR); with Implicit VR, the receiving application must use a DICOM data dictionary to look up the format of each data element.

1.8 SYMBOLS AND ABBREVIATIONS

AE	Application Entity
AET	Application Entity Title
CAD	Computer Aided Detection
CAK	Cumulative Air Kerma
CDA	Clinical Document Architecture
CD-R	Compact Disk Recordable
CSE	Customer Service Engineer
CR	Computed Radiography
CT	Computed Tomography
DAP	Dose Area Product
DHCP	Dynamic Host Configuration Protocol
DICOM	Digital Imaging and Communications in Medicine
DIT	Directory Information Tree (LDAP)
DN	Distinguished Name (LDAP)
DNS	Domain Name System
FSC	File-Set Creator
FSU	File-Set Updater
FSR	File-Set Reader
GSDF	Grayscale Standard Display Function
GSPS	Grayscale Softcopy Presentation State
Gy	Gray a derived unit of ionizing radiation dose.
HIS	Hospital Information System
HL7	Health Level 7 Standard

IHE	Integrating the Healthcare Enterprise
IOD	Information Object Definition
IPv4	Internet Protocol version 4
IPv6	Internet Protocol version 6
ISO	International Organization for Standards
IOD	Information Object Definition
JPEG	Joint Photographic Experts Group
LDAP	Lightweight Directory Access Protocol
LDIF	LDAP Data Interchange Format
LUT	Look-up Table
mAs	Milliamperere seconds – unit of measure used in X-ray imaging.
mGy	Milli-gray – 1000 mGy make up a Gy.
mGycm ²	Unit used for DAP.
MPEG	Moving Picture Experts Group
MG	Mammography (X-ray)
MPPS	Modality Performed Procedure Step
MR	Magnetic Resonance Imaging
MTU	Maximum Transmission Unit (IP)
MWL	Modality Worklist
NM	Nuclear Medicine
NTP	Network Time Protocol
O	Optional (Key Attribute)
OSI	Open Systems Interconnection
PACS	Picture Archiving and Communication System
PET	Positron Emission Tomography
PDU	Protocol Data Unit
R	Required (Key Attribute) – Dependent on context of where used.
RDN	Relative Distinguished Name (LDAP)

RDSR	Radiation Dose Structured Report
RF	Radiofluoroscopy
RIS	Radiology Information System
RT	Radiotherapy
SC	Secondary Capture
SCP	Service Class Provider
SCU	Service Class User
SOP	Service-Object Pair
SPS	Scheduled Procedure Step
SR	Structured Reporting
TCP/IP	Transmission Control Protocol/Internet Protocol
uAs	Microampere seconds – unit of measure used in X-ray imaging.
U	Unique (Key Attribute)
UL	Upper Layer
US	Ultrasound
VR	Value Representation
XA	X-ray Angiography

2. NETWORK CONFORMANCE STATEMENT

2.1 INTRODUCTION

This section of the DICOM Conformance Statement specifies the OEC Elite compliance to DICOM requirements for **Networking** features.

GEHC OEC Elite Family for X-Ray system runs on a single board computer. It allows for the following DICOM functionality:

- Initiates and responds to a DICOM C-Echo message to assist in network diagnostics.
- Initiates a DICOM association to send each image and/or report.
- Sends DICOM images and RDSR to a DICOM Store SCP (PACS).
- Sends DICOM Storage Commitment to PACS.
- Sends DICOM MPPS to RIS.
- Querying and retrieving DICOM Modality Worklist from a Worklist SCP (RIS).
- Printing acquired images to a DICOM Printer.
- Querying and retrieving saved examinations from a DICOM Query/Retrieve SCP.

2.2 IMPLEMENTATION MODEL

2.2.1 Application Data Flow Diagram

The network application model for the OEC ELITE is shown in the following Illustration :

ILLUSTRATION 2-1
OEC ELITE NETWORK APPLICATION MODEL AND DATA FLOW DIAGRAM

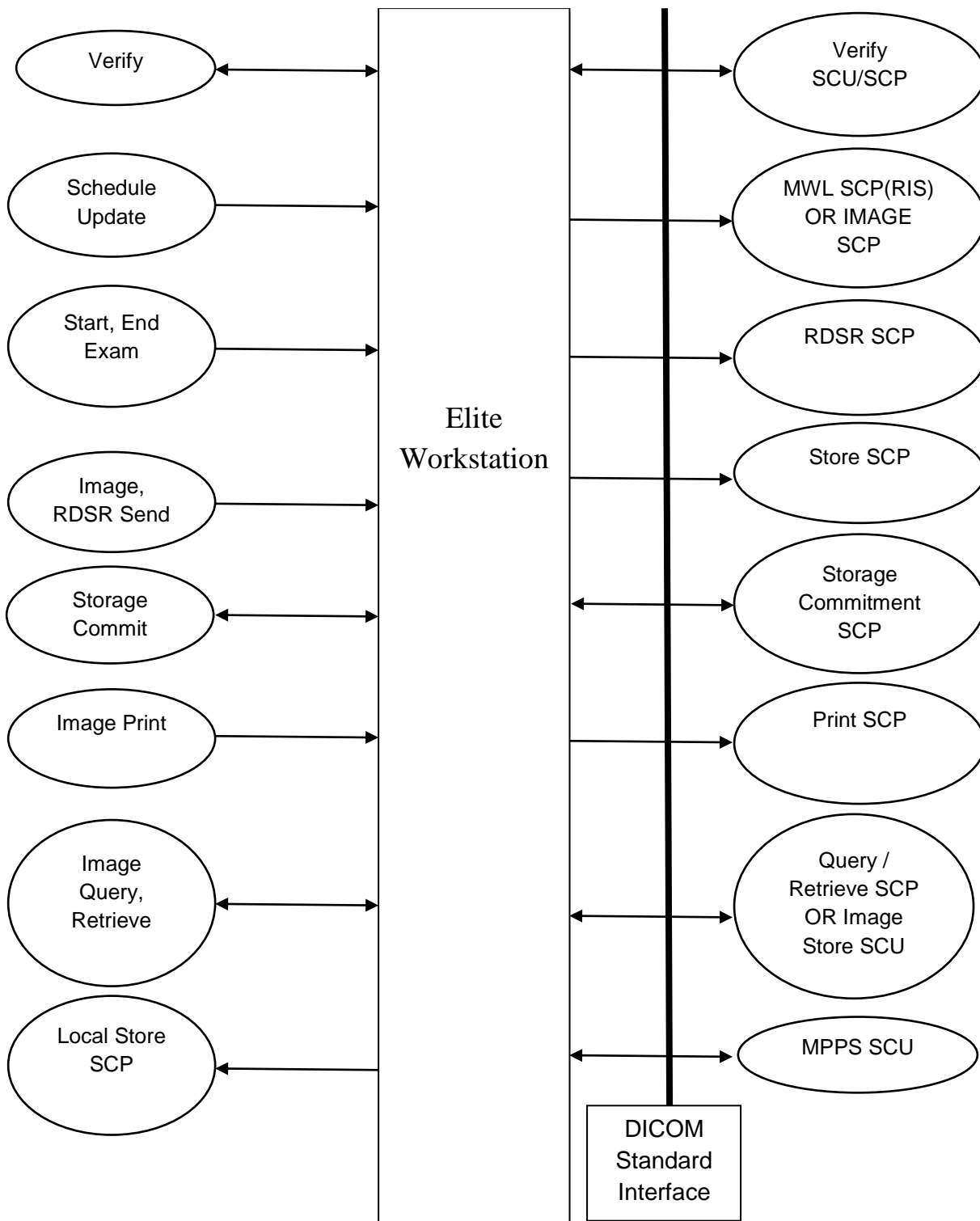

The product supports Verify which performs a check of communication to a remote server including the AE title of the Remote SCP; the results of Verify are communicated to user on the server configuration screens(Store/Store Commit, MWL, Query/Retrieve or DICOM Print). Remote Servers can also use the Verify (C-ECHO) function to confirm communication to the Elite Workstation.

The product supports Schedule Update which performs a worklist query to a Remote MWL SCP; the results are displayed to user on the Elite Workstation

The product supports Update Schedule which performs an image query to a Remote Store SCP; the results are displayed to user on the Elite Workstation

The product supports Image, RDSR Send which performs a 'Send' to a Remote Store SCP of the image or RDSR; the user is shown status of the Send operation.

The product supports Storage Commit which performs 'Storage commit' to a Remote Store SCP of the image or RDSR; the user is shown status of the Store Commit operation.

The product supports Image Print which performs a print to a Remote Print SCP of the image(s); the user is able to layout the images for the print operation.

The product supports Image Query/Retrieve which performs a query to a Remote Query/Retrieve SCP for a series containing images ; the user is able to retrieve the series and view the images if supported on the Elite Workstation.

The product supports a Remote Image Store to the Local Store SCP which allows the user to store supported images directly to the Elite Workstation.

2.2.2 Functional Definition of AE's

Application Entity "Elite Workstation" supports the following functions:

- Initiates a DICOM verification and responds to a DICOM verification to assist in network diagnostics.
- Initiates a DICOM association to query for examination information (MWL Worklist query).
- Initiates a Study Root Query to get patient demographics ("Patient Information Only" Image query to populate the scheduled exam).
- Initiates a DICOM association to send an image or RDSR.
- Transmits DICOM images and RDSR to the DICOM Storage SCP.
- Initiates a DICOM association to send MPPS messages to RIS.
- Initiates a DICOM association for storage commitment of images and RDSR.
- Initiates a DICOM association to print images.
- Transmits images data, patient and dose summary report to DICOM Print SCP.

- Initiates a DICOM association to query for desired examinations for Q/R service.
- Accepts DICOM associations for DICOM Store requests in retrieve (move) operation.
- Accepts DICOM associations for DICOM Store requests for direct image store operation.

2.2.3 Sequencing of Real-World Activities

1. Network configuration of the system should be accomplished first.
2. System configuration allows for Store, Storage Commitment, Print, MWL, and Query/Retrieve configuration of Remote SCPs which will have a server alias name on the Elite Workstation.
3. DICOM Verification should be performed during configuration enabling the user to perform network diagnostics before procedures. The verification is available for all Store/ Storage Commit server, Print server, Query/Retrieve server, and Worklist query server configurations allowed on the system.
4. Schedule Update should be performed prior to starting an exam; otherwise the user can input the exam information.
5. For Image Query, the Remote Query SCP server must be configured with the Elite Workstation AE Title, IP Address and Retrieve(C-Store)/Storage Commit port for the local server.
6. Retrieval of images should be performed prior to an exam but can be performed during the exam.
7. Image Send can be performed during or after the exam.
8. End Exam should be done when the user is done using the X-ray capabilities of the OEC Elite. This will create the RDSR(s) for the exam on a per procedure step basis. Automatic storage of the RDSR can be configured.
9. Image Print can be performed during or after the exam.
10. Networking will be terminated by the Elite Workstation if the user requests the system to create X-rays.
11. Images and RDSR can be sent to a properly formatted USB mass storage device. The OEC Elite can also format the USB mass storage device up to 2 TB as FAT32.
12. MPPS messages are sent when a MPPS server is configured. N-CREATE at first x-ray or start of exam. N-SET when exam is completed or abandoned.

2.3 AE SPECIFICATIONS

Configuration must be completed and saved before the system is able to perform DICOM Store/Storage Commit, Print, MWL Query, MPPS, or Query/Retrieve.AE Specifications.

2.3.1 Elite Workstation Specification

The Elite Workstation Application Entity provides Standard Conformance to the following DICOM SOP Classes as an **SCU** and/or as an **SCP**. Anything that is marked “No” for SCU cannot be generated on the system.

SOP Class Name	SOP Class UID	SCU	SCP
Verification SOP Class	1.2.840.10008.1.1	Yes	Yes
Computed Radiography Image Storage	1.2.840.10008.5.1.4.1.1.1	Yes	Yes
Digital X-Ray Image Storage - For Presentation	1.2.840.10008.5.1.4.1.1.1.1	No	Yes
Digital X-Ray Image Storage - For Processing	1.2.840.10008.5.1.4.1.1.1.1.1	No	Yes
Digital Mammography X-Ray Image Storage – For Presentation	1.2.840.10008.5.1.4.1.1.1.2	No	Yes
Digital Mammography X-Ray Image Storage – For Processing	1.2.840.10008.5.1.4.1.1.1.2.1	No	Yes
CT Image Storage	1.2.840.10008.5.1.4.1.1.2	No	Yes
Ultrasound Multi-frame Image Storage	1.2.840.10008.5.1.4.1.1.3.1	No	Yes
MR Image Storage	1.2.840.10008.5.1.4.1.1.4	No	Yes
MR Spectroscopy Storage	1.2.840.10008.5.1.4.1.1.4.2	No	Yes
Ultrasound Image Storage	1.2.840.10008.5.1.4.1.1.6.1	No	Yes
Secondary Capture Image Storage	1.2.840.10008.5.1.4.1.1.7	Yes	Yes
Multi-frame Grayscale Byte Secondary Capture Image Storage	1.2.840.10008.5.1.4.1.1.7.2	Yes	Yes
X-Ray Angiographic Image Storage	1.2.840.10008.5.1.4.1.1.12.1	Yes	Yes
X-Ray Radiofluoroscopic Image Storage	1.2.840.10008.5.1.4.1.1.12.2	Yes	Yes
X-Ray Radiation Dose SR	1.2.840.10008.5.1.4.1.1.88.67	Yes	Yes
RT Image Information Storage	1.2.840.10008.5.1.4.1.1.481.1	No	Yes
Patient Root Query/Retrieve Information Model – FIND	1.2.840.10008.5.1.4.1.2.1.1	Yes	No
Patient Root Query/Retrieve Information Model - MOVE	1.2.840.10008.5.1.4.1.2.1.2	Yes	No
Study Root Query/Retrieve Information Model - FIND	1.2.840.10008.5.1.4.1.2.2.1	Yes	No
Study Root Query/Retrieve Information Model - MOVE	1.2.840.10008.5.1.4.1.2.2.2	Yes	No
Modality Worklist Information Model - FIND	1.2.840.10008.5.1.4.31	Yes	No
Modality Performed Procedure Step SOP Class	1.2.840.10008.3.1.2.3.3	Yes	No
Storage Commitment Push Model	1.2.840.10008.1.20.1	Yes	No
Basic Film Session SOP Class	1.2.840.10008.5.1.1.1	Yes	No
Basic Film Box SOP Class	1.2.840.10008.5.1.1.2	Yes	No
Basic Grayscale Image Box SOP Class	1.2.840.10008.5.1.1.4	Yes	No

SOP Class Name	SOP Class UID	SCU	SCP
Basic Grayscale Print Management Meta SOP Class	1.2.840.10008.5.1.1.9	Yes	No
Printer SOP Class	1.2.840.10008.5.1.1.16	Yes	No
Presentation LUT SOP Class	1.2.840.10008.5.1.1.23	Yes	No

2.3.1.1 Association Establishment Policies

2.3.1.1.1 General

The DICOM Application Context Name (ACN), which is always proposed, is:

Application Context Name	1.2.840.10008.3.1.1.1
---------------------------------	------------------------------

The maximum length PDU receive size for the Elite Workstation is:

Maximum Length PDU	16384 (Not Configurable)
---------------------------	---------------------------------

2.3.1.1.2 Number of Associations

The Elite Workstation will initiate a maximum of 1 simultaneous Initiator(SCU) association to remote nodes.

The Elite Workstation will support a maximum of 1 simultaneous Acceptor(SCP) association initiated by remote nodes for C-STORE.

There is one association going in each direction, one for the SCU operation and one for the SCP operation of the Elite Workstation. This allows a Storage Commit (N-EVENT-REPORT) to be received when another C-STORE may be in progress.

2.3.1.1.3 Asynchronous Nature

Asynchronous mode is not supported. All operations will be performed synchronously. The only exceptions are for N-EVENT-REPORTS for Storage Commit and Print Management operations.

2.3.1.1.4 Implementation Identifying Information

The Implementation UID for this DICOM Implementation is:

OEC Elite Implementation UID	1.2.840.113619.6.329
OEC Elite Implementation Version Name	OEC ELITE v1.1

2.3.1.2 Association Initiation Policy

When the Elite Workstation Application Entity initiates an Association for any Real-World Activity, it will propose the Presentation Context for the Real-World Activity; i.e., there is only a single, Presentation Context Negotiation proposed by the AE for C-STORE of XA IOD.

The Elite Workstation proposes Three Transfer Syntax in each Presentation Context; i.e., for each Abstract Syntax in the following Presentation Context Tables, the AE proposes one Presentation Context with three Transfer Syntax.

2.3.1.2.1 Real-World Activity Verify

2.3.1.2.1.1 Associated Real-World Activity

Pressing the 'Verify' button on the Server configuration screen for any of the following server screens: MWL, Store/Store Commit, Print or Query/Retrieve.

2.3.1.2.1.2 Proposed Presentation Context Table

Presentation Context Table – Proposed by AE Elite Workstation for Activity Verify					
Abstract Syntax		Transfer Syntax		Role	Extended Negotiation
Name	UID	Name List	UID List		
Verification SOP Class	1.2.840.10008.1.1	Implicit VR Little Endian	1.2.840.10008.1.2	SCU	None
		Explicit VR Little Endian	1.2.840.10008.1.2.1		
		Explicit VR Big Endian	1.2.840.10008.1.2.2		

2.3.1.2.2 Real-World Activity Schedule Update

2.3.1.2.2.1 Associated Real-World Activity

The user can initiate a Schedule Update by pressing the 'Update Schedule' button on the Scheduled Exams screen.

2.3.1.2.2.2 Proposed Presentation Context Table

The Modality Worklist Information Model – FIND is used if the user has configured the MWL server on the OEC Elite to be DICOM Query Type of 'Worklist'.

The Study Root Query/Retrieve Information Model – FIND is used if the user has configured the MWL server on the OEC Elite to be DICOM Query Type of 'Image' instead of 'Worklist'.

The Elite Workstation includes the specific character set of "ISO_IR 100" in a request. Responses with another character set are ignored.

Presentation Context Table - Proposed by AE Elite Workstation for Activity Schedule Update					
Abstract Syntax		Transfer Syntax		Role	Extended Negotiation
Name	UID	Name List	UID List		
Study Root Query/Retrieve Information Model - FIND	1.2.840.10008.5.1.4.1.2.2.1	Implicit VR Little Endian	1.2.840.10008.1.2	SCU	None
		Explicit VR Little Endian	1.2.840.10008.1.2.1		
		Explicit VR Big Endian	1.2.840.10008.1.2.2		
Modality Worklist Information Model - FIND	1.2.840.10008.5.1.4.31	Implicit VR Little Endian	1.2.840.10008.1.2	SCU	None
		Explicit VR Little Endian	1.2.840.10008.1.2.1		
		Explicit VR Big Endian	1.2.840.10008.1.2.2		

2.3.1.2.2.2.1 SOP Specific DICOM Conformance Statement for the Modality Worklist Information Model - FIND SOP Class

The Elite Workstation includes matching keys in the Modality Worklist queries as described in Section 10

Modality Worklist Query Implementation.

The Scheduled Exam screen will be populated with the results of the FIND query based on the returned data from the server. If a response matches an exam that the system has in its database, the system will not display that result again. The OEC Workstation will only display 500 responses. The responses will remain on the system until they are used for an exam by being selected or another Schedule Update is performed.

If the user selects the Cancel button on the Schedule Update progress bar, a C-FIND CANCEL will be sent if the association is not yet complete.

Following are the status codes that are more specifically processed when receiving messages from a **Modality Worklist** SCP equipment :

Service Status	Status Code	Further Meaning	Application Behavior When Receiving Status Code
Failure	A700	Refused: Out of resources	Error displayed to the user and logged for viewing in the Event Log.
	A900	Error: Identifier does not match SOP Class	Error displayed to the user and logged for viewing in the Event Log.
	C000-CFFF	Error: Unable to process	Error displayed to the user and logged for viewing in the Event Log.
	0122	SOP Class Not Supported	Error displayed to the user and logged for viewing in the Event Log.
Cancel	FE00	Matching terminated due to cancel	Logged for viewing in the Event Log.
Success	0000	Matching is complete - No final identifier is supplied	Display the list.
Pending	FF00	Matches are continuing - Current Match is supplied and any Optional Keys were supported in the same manner as Required Keys.	Show progress to user.
	FF01	Matches are continuing - Warning that one or more Optional Keys were not supported for existence for this Identifier	Show progress to user.
*	*	Any other status code.	Error displayed to the user and logged for viewing in the Event Log.

2.3.1.2.2.2 SOP Specific DICOM Conformance Statement for the Study Root Query/Retrieve Information Model - FIND SOP Class for Schedule Update

The Elite Workstation includes matching keys in the queries as described in Section 14

QUERY Implementation.

The Elite Workstation includes the specific character set of “ISO_IR 100” in a request. Responses with another character set are ignored.

If the user selects the Cancel button on the Schedule Update progress bar, a C-FIND CANCEL will be sent if the association is not yet complete.

Following are the status codes that are more specifically processed when receiving messages from a **Query** SCP equipment :

Service Status	Status Code	Further Meaning	Application Behavior When Receiving Status Code
Failure	A700	Refused: Out of resources	Error displayed to the user and logged for viewing in the Event Log.
	A900	Error: Identifier does not match SOP Class	Error displayed to the user and logged for viewing in the Event Log.
	C000-CFFF	Error: Unable to process	Error displayed to the user and logged for viewing in the Event Log.
	0122	SOP Class Not Supported	Error displayed to the user and logged for viewing in the Event Log.
Cancel	FE00	Matching terminated due to cancel	Logged for viewing in the Event Log.
Success	0000	Matching is complete - No final identifier is supplied	Display the list.
Pending	FF00	Matches are continuing - Current Match is supplied and any Optional Keys were supported in the same manner as Required Keys.	Show progress to user.
	FF01	Matches are continuing - Warning that one or more Optional Keys were not supported for existence and/or matching for this Identifier	Show progress to user.
*	*	Any other status code.	Error displayed to the user and logged for viewing in the Event Log.

2.3.1.2.3 Real-World Activity Start/End Exam

2.3.1.2.3.1 Associated Real-World Activity

The system will start collecting X-ray dose information for the selected exam as soon as the X-ray activation switch is pressed. This starts the exam.

The user is provided a control to end/abandon an exam on the Image and Saved Exams screens. This will create the RDSR and optionally send the RDSR to an RDSR SCP.

2.3.1.2.3.2 Proposed Presentation Context Table

See Image RDSR Send and Storage Commit section 2.3.1.2.4 to see RDSR conformance.

2.3.1.2.3.2.1 SOP Specific DICOM Conformance Statement for Modality Performed Procedure Step SOP Class

The Elite Workstation will send an N-CREATE MPPS message at the start of an exam (first x-ray).

The Elite Workstation will send an N-SET MPPS message completing or abandoning the exam per the instructions from the user. Using the human interface the user is able to complete or abandon (end) and exam.

The Elite Workstation includes attributes in the Modality Performed Procedure Step N-CREATE as described in Section 11.

The Elite Workstation uses many of MWL attributes in setting values for MPPS including Scheduled Protocol Code Sequence.

Following are the status codes that are more specifically processed when receiving an **N-Create response** from an **MPPS** SCP equipment:

Service Status	Status Code	Further Meaning	Application Behavior When Receiving Status Code
Failure	0119	Class-instance conflict	Error is logged and entry is placed into transfer status queue.
	0210	Duplicate invocation	Error is logged and entry is placed into transfer status queue.
	0111	Duplicate SOP Instance	Error is logged and entry is placed into transfer status queue.
	0106	Invalid attribute value	Error is logged and entry is placed into transfer status queue.
	0117	Invalid SOP instance	Error is logged and entry is placed into transfer status queue.
	0120	Missing attribute	Error is logged and entry is placed into transfer status queue.
	0121	Missing attribute value	Error is logged and entry is placed into transfer status queue.

	0212	Mistyped argument	Error is logged and entry is placed into transfer status queue.
	0105	No such attributes	Error is logged and entry is placed into transfer status queue.
	0118	No such SOP Class	Error is logged and entry is placed into transfer status queue.
	0112	No such SOP Instance	Error is logged and entry is placed into transfer status queue.
	0110	Processing failure	Error is logged and entry is placed into transfer status queue.
	0213	Resource limitation	Error is logged and entry is placed into transfer status queue.
	0211	Unrecognized operation	Error is logged and entry is placed into transfer status queue.
Success	0000		Success placed in the transfer status screen.
*	*	Any other status code.	Error is logged and entry is placed into transfer status queue.

The OEC Elite will set MPPS to COMPLETED or DISCONTINUED, according to the dialogs selected by the user for the exam.

The AE includes attributes in the Modality Performed Procedure Step N-SET as described in Section 11.

Following are the status codes that are more specifically processed when receiving an **N-Set response** from an **MPPS SCP** equipment:

Service Status	Status Code	Further Meaning	Application Behavior When Receiving Status Code
Failure	0119	Class-instance conflict	Error is logged and entry is placed into transfer status queue.
	0210	Duplicate invocation	Error is logged and entry is placed into transfer status queue.
	0106	Invalid attribute value	Error is logged and entry is placed into transfer status queue.
	0212	Mistyped argument	Error is logged and entry is placed into transfer status queue.
	0117	Invalid SOP instance	Error is logged and entry is placed into transfer status queue.

	0121	Missing attribute value	Error is logged and entry is placed into transfer status queue.
	0105	No such attributes	Error is logged and entry is placed into transfer status queue.
	0118	No such SOP Class	Error is logged and entry is placed into transfer status queue.
	0112	No such SOP Instance	Error is logged and entry is placed into transfer status queue.
	0110	Processing failure	Error is logged and entry is placed into transfer status queue.
	0213	Resource limitation	Error is logged and entry is placed into transfer status queue.
	0211	Unrecognized operation	Error is logged and entry is placed into transfer status queue.
Success	0000		Success placed in the transfer status screen.
*	*	Any other status code.	Error is logged and entry is placed into transfer status queue.

2.3.1.2.4 Real-World Activity Image/RDSR Send and Storage Commit

2.3.1.2.4.1 Associated Real-World Activity

The user is able to store Images and RDSRs from the Images screen. Images can be stored at any time during or after the exam. RDSRs are only available after an exam is ended with a End Exam or Complete Exam.

The Abstract syntax selected is based on the configuration of the Store SCP on the Elite Workstation or by the data item selected on the Images screen(Dose Summary, Patient Summary and Radiation Dose Structure Report).

The Patient Summary and Dose Summary screens can be sent to the Store SCP and will always be sent as a Secondary Capture Image Storage.

2.3.1.2.4.2 Proposed Presentation Context Table

The Elite Workstation will negotiate the association as an SCU only. The Elite Workstation product is implementing Storage Commitment SOP Class as an SCP for this Real-World Activity (see section 2.3.1.3.2), since N-Event-Report Request shall be sent on a separate association initiated by the SCP.

Presentation Context Table – Proposed by AE Elite Workstation for Activity Image/RDSR Send and Storage Commit

Abstract Syntax		Transfer Syntax		Role	Extended Negotiation
Name	UID	Name List	UID List		
Storage Commitment Push Model	1.2.840.10008.1.20.1	Implicit VR Little Endian Explicit VR Little Endian Explicit VR Big Endian	1.2.840.10008.1.2 1.2.840.10008.1.2.1 1.2.840.10008.1.2.2	SCU	None
Computed Radiography Image Storage	1.2.840.10008.5.1.4.1.1.1	Implicit VR Little Endian Explicit VR Little Endian Explicit VR Big Endian	1.2.840.10008.1.2 1.2.840.10008.1.2.1 1.2.840.10008.1.2.2	SCU	None
X-Ray Angiographic Image Storage	1.2.840.10008.5.1.4.1.1.12.1	Implicit VR Little Endian Explicit VR Little Endian Explicit VR Big Endian	1.2.840.10008.1.2 1.2.840.10008.1.2.1 1.2.840.10008.1.2.2	SCU	None
X-Ray Radiofluoroscopic Image Storage	1.2.840.10008.5.1.4.1.1.12.2	Implicit VR Little Endian Explicit VR Little Endian Explicit VR Big Endian	1.2.840.10008.1.2 1.2.840.10008.1.2.1 1.2.840.10008.1.2.2	SCU	None
Secondary Capture Image Storage	1.2.840.10008.5.1.4.1.1.7	Implicit VR Little Endian Explicit VR Little Endian Explicit VR Big Endian	1.2.840.10008.1.2 1.2.840.10008.1.2.1 1.2.840.10008.1.2.2	SCU	None
X-Ray Radiation Dose SR Storage (RDSR)	1.2.840.10008.5.1.4.1.1.88.67	Implicit VR Little Endian Explicit VR Little Endian Explicit VR Big Endian	1.2.840.10008.1.2 1.2.840.10008.1.2.1 1.2.840.10008.1.2.2	SCU	None

2.3.1.2.4.2.1 SOP Specific DICOM Conformance Statement for All Storage SOP Classes

The Elite Workstation includes optional data elements in the SOP Instances as described in Sections:

X-Ray Angiographic Information Object Implementation,

X-Ray RF Information Object Implementation,

Secondary Capture Information Object Implementation

2.4 INTRODUCTION

This section specifies the use of the DICOM SC Image IOD to represent the information included in SC Images produced or received by this implementation. Corresponding attributes are conveyed using the module construct.

2.5 OEC ELITE MAPPING OF DICOM ENTITIES

The OEC Elite maps DICOM Information Entities to local Information Entities in the product’s database and user interface.

**TABLE 7-1
 MAPPING OF DICOM ENTITIES TO OEC ELITE ENTITIES**

DICOM IE	OEC Elite Entity
Patient	Patient
Study	Exam
Series	Series
Image	Image

2.6 IOD MODULE TABLE

The Secondary Capture Information Object Definition comprises the modules of the following table, plus Standard Extended and Private attributes. Standard Extended and Private attributes are described in Section 8.4.1.

**TABLE 7-2
SC IMAGE IOD MODULES**

Entity Name	Module Name	Usage	Reference
Patient	Patient	Used	4.4.1.1
	Clinical Trial Subject	Not Used	N/A
Study	General Study	Used	4.4.2.1
	Patient Study	Used when the data is passed by the Modality Worklist.	4.4.2.2
	Clinical Trial Study	Not Used	N/A
Series	General Series	Used	4.4.3.1
	Clinical Trial Series	Not Used	N/A
Equipment	General Equipment	Used	4.4.4.1
	SC Equipment	Used	Error! Reference source not found.
Image	General Image	Used	4.4.5.1
	General Reference	Not Used	N/A
	Image Pixel	Used	4.4.5.2
	Device	Not Used	N/A
	Specimen	Not Used	N/A
	SC Image	Used	Error! Reference source not found.
	Overlay Plane	Used when the user specifies the overlay to be stored for a DICOM Store and always used in Media.	4.4.5.8
	Modality LUT	Not Used	N/A
	VOI LUT	Used to provide the Window Width and Center for the image.	4.4.5.9
	ICC Profile	Not Used	N/A
	SOP Common	Used	4.4.5.10
	Common Instance Reference	Not Used	N/A

2.7 INFORMATION MODULE DEFINITIONS

Please refer to DICOM Standard Part 3 (Information Object Definitions) for a description of each of the entities and modules contained within the SC Information Object.

The following modules are included to convey Enumerated Values, Defined Terms, and Optional Attributes supported or expected. Type 1 & Type 2 Attributes are also included for completeness and to define what values they may take and where these values are obtained from when generating the instance as well as what are the expected values when loading such instance. It should be noted that they are the same ones as defined in the

DICOM Standard Part 3 (Information Object Definitions). Also note that Attributes not present in tables are not supported.

2.7.1 Equipment Entity Modules

2.7.1.1 SC Equipment Module

**TABLE 7-3
SC EQUIPMENT MODULE ATTRIBUTES**

Attribute Name	Tag	Type	Use
Conversion Type	(0008,0064)	1	The value will be set to WSD.
Modality	(0008,0060)	3	The value will be set to OT.
Secondary Capture Device ID	(0018,1010)	3	The value is set to the system serial number.
Secondary Capture Device Manufacturer	(0018,1016)	3	The value is set to the "GE Healthcare ".
Secondary Capture Device Manufacturer's Model Name	(0018,1018)	3	The value is set to the model of the system.
Secondary Capture Device Software Version	(0018,1019)	3	The value is set to the software version of the system.

2.7.2 Image Entity Modules

2.7.2.1 SC Image Module

**TABLE 7-4
SC IMAGE MODULE ATTRIBUTES**

Attribute Name	Tag	Type	Use
Date of Secondary Capture	(0018,1012)	3	The value is set to the date the image is created on the system.
Time of Secondary Capture	(0018,1014)	3	The value is set to the time the image is created on the system.

2.8 STANDARD EXTENDED AND PRIVATE DATA ATTRIBUTES

The Product does not support any additional standard extended attributes in Standard Extended SC SOP Instances as Type 3 data elements.

2.9 STANDARD EXTENDED AND PRIVATE CONTEXT GROUPS

The Product does not support coded terminology using any Standard Extended, Private, or Configurable Context Groups defined in the following sections.

Multi-frame Grayscale byte SC Information Object Implementation (section 0),

CR Information Object Implementation, and

X-Ray Radiation Dose Structured Report Information Object Implementation.

Following are the status codes that are more specifically processed when receiving messages from a **Storage** SCP equipment :

Service Status	Status Code	Further Meaning	Application Behavior When Receiving Status Code
Failure	A700-A7FF	Refused: Out of resources	Error displayed to the user and logged for viewing in the Event Log.
	A900-A9FF	Error: Data Set does not match SOP Class	Error displayed to the user and logged for viewing in the Event Log.
	C000-CFFF	Error: Cannot Understand	Error displayed to the user and logged for viewing in the Event Log.
	0122	SOP Class Not Supported	Error displayed to the user and logged for viewing in the Event Log.
Warning	B000	Coercion of Data Elements	Error displayed to the user and logged for viewing in the Event Log.
	B006	Elements Discarded	Error displayed to the user and logged for viewing in the Event Log.
	B007	Data Set does not match SOP Class	Error displayed to the user and logged for viewing in the Event Log.
Success	0000		Success will be logged for viewing in the Event Log.
*	*	Any other status code.	Error displayed to the user and logged for viewing in the Event Log.

2.9.1.1.1.1 SOP Specific DICOM Conformance Statement for the X-Ray Radiation Dose Storage SOP Classes

See Section 2.3.1.2.4.2.1 "SOP Specific DICOM Conformance Statement for All Storage SOP Classes" for details on general Storage Service SCU processing also applicable to the X-Ray Radiation Dose Storage SOP Classes.

The Elite Workstation supports creation and transmission of X-Ray Radiation Dose SOP Instances referencing Instances of the following Storage SOP Classes(see Note below table):

SOP Class Name	SOP Class UID
Computed Radiography Image Storage	1.2.840.10008.5.1.4.1.1.1
X-Ray Angiographic Image Storage	1.2.840.10008.5.1.4.1.1.12.1
X-Ray Radiofluoroscopic Image Storage	1.2.840.10008.5.1.4.1.1.12.2

Secondary Capture Image Storage	1.2.840.10008.5.1.4.1.1.7
---------------------------------	---------------------------

Note – The images must be stored (Image Send) prior to End Exam.

2.9.1.1.1.2 SOP Specific DICOM Conformance Statement for the Storage Commitment Push Model SOP Class SCU

The Elite Workstation will request a Storage Commitment for each Image/RDSR Send, if the Store/Store Commit Server Configuration screen has ‘Enable Storage Commit’ enabled.

The Elite Workstation uses DICOM network storage services to transfer SOP Instances which are to be committed. It does not support the optional Storage Media File-Set ID and UID Attributes in the Storage Commitment N-ACTION for transfer of SOP Instances by media for Storage Commitment.

The Elite Workstation may request Storage Commitment for Instances of any of the Composite SOP Classes it supports as an SCU (see Section 2.3.1.2.4.2).

The Storage Commitment Information Object is described in Section 11.

Following are the status codes that are more specifically processed when receiving N-ACTION responses from a **Storage Commitment** SCP equipment:

Service Status	Status Code	Further Meaning	Application Behavior When Receiving Status Code
Failure	0119	Class-instance conflict	Error displayed to the user and logged for viewing in the Event Log.
	0210	Duplicate invocation	Error displayed to the user and logged for viewing in the Event Log.
	0115	Invalid argument value	Error displayed to the user and logged for viewing in the Event Log.
	0117	Invalid SOP Instance	Error displayed to the user and logged for viewing in the Event Log.
	0212	Mistyped argument	Error displayed to the user and logged for viewing in the Event Log.
	0123	No such action	Error displayed to the user and logged for viewing in the Event Log.
	0114	No such argument	Error displayed to the user and logged for viewing in the Event Log.
	0118	No such SOP Class	Error displayed to the user and logged for viewing in the Event Log.
	0112	No such SOP Instance	Error displayed to the user and logged for viewing in the Event Log.

Service Status	Status Code	Further Meaning	Application Behavior When Receiving Status Code
	0110	Processing failure	Error displayed to the user and logged for viewing in the Event Log.
	0213	Resource limitation	Error displayed to the user and logged for viewing in the Event Log.
	0211	Unrecognized operation	Error displayed to the user and logged for viewing in the Event Log.
Success	0000		Success will be logged for viewing in the Event Log.
*	*	Any other status code.	Error displayed to the user and logged for viewing in the Event Log.

A Storage Commit N-EVENT-REPORT can not be received on the Association initiated by this Application Entity, as SCP SCU Role selection only allows SCU Role (see Section 2.9.1.2.2).

2.9.1.1.2 Real-World Activity Image Query/Retrieve and Local Store SCP

2.9.1.1.2.1 Associated Real-World Activity

Image Query is performed when the user requests a ‘Query’ from the Images > Retrieve screen.

Image Retrieve is performed when the user selects an exam to retrieve and requests a ‘Retrieve’ from the Images > Retrieve screen.

Configuration of the Query/Retrieve server determines the Q/R Information Model used during system operation – FIND and MOVE.

2.9.1.1.2.2 Proposed Presentation Context Table

Presentation Context Table - Proposed by AE Elite Workstation for Activity Image Query/Retrieve					
Abstract Syntax		Transfer Syntax		Role	Extended Negotiation
Name	UID	Name List	UID List		
Study Root Query/Retrieve Information Model - FIND	1.2.840.10008.5.1.4.1.2.2.1	Implicit VR Little Endian	1.2.840.10008.1.2	SCU	None
		Explicit VR Little Endian	1.2.840.10008.1.2.1		
		Explicit VR Big Endian	1.2.840.10008.1.2.2		
Study Root Query/Retrieve Information Model - MOVE	1.2.840.10008.5.1.4.1.2.2.2	Implicit VR Little Endian	1.2.840.10008.1.2	SCU	None
		Explicit VR Little Endian	1.2.840.10008.1.2.1		
		Explicit VR Big Endian	1.2.840.10008.1.2.2		
Patient Root Query/Retrieve	1.2.840.10008.5.1.4.1.2.2.1	Implicit VR Little Endian	1.2.840.10008.1.2	SCU	None

Information Model - FIND		Explicit VR Little Endian Explicit VR Big Endian	1.2.840.10008.1.2.1 1.2.840.10008.1.2.2		
Patient Root Query/Retrieve Information Model - MOVE	1.2.840.10008.5.1.4.1.2.2.2	Implicit VR Little Endian Explicit VR Little Endian Explicit VR Big Endian	1.2.840.10008.1.2 1.2.840.10008.1.2.1 1.2.840.10008.1.2.2	SCU	None
Computed Radiography Image Storage	1.2.840.10008.5.1.4.1.1.1	Implicit VR Little Endian Explicit VR Little Endian Explicit VR Big Endian	1.2.840.10008.1.2 1.2.840.10008.1.2.1 1.2.840.10008.1.2.2	SCP	None
X-Ray Angiographic Image Storage	1.2.840.10008.5.1.4.1.1.12.1	Implicit VR Little Endian Explicit VR Little Endian Explicit VR Big Endian	1.2.840.10008.1.2 1.2.840.10008.1.2.1 1.2.840.10008.1.2.2	SCP	None
X-Ray Radiofluoroscopic Image Storage	1.2.840.10008.5.1.4.1.1.12.2	Implicit VR Little Endian Explicit VR Little Endian Explicit VR Big Endian	1.2.840.10008.1.2 1.2.840.10008.1.2.1 1.2.840.10008.1.2.2	SCP	None
Secondary Capture Image Storage	1.2.840.10008.5.1.4.1.1.7	Implicit VR Little Endian Explicit VR Little Endian Explicit VR Big Endian	1.2.840.10008.1.2 1.2.840.10008.1.2.1 1.2.840.10008.1.2.2	SCP	None
Multi-frame Grayscale Byte SC Image Storage	1.2.840.10008.5.1.4.1.1.7.2	Implicit VR Little Endian Explicit VR Little Endian Explicit VR Big Endian	1.2.840.10008.1.2 1.2.840.10008.1.2.1 1.2.840.10008.1.2.2	SCP	None
Digital X-Ray Image Storage - For Presentation	1.2.840.10008.5.1.4.1.1.1.1	Implicit VR Little Endian Explicit VR Little Endian Explicit VR Big Endian	1.2.840.10008.1.2 1.2.840.10008.1.2.1 1.2.840.10008.1.2.2	SCP	None
Digital X-Ray Image Storage - For Processing	1.2.840.10008.5.1.4.1.1.1.1.1	Implicit VR Little Endian Explicit VR Little Endian Explicit VR Big Endian	1.2.840.10008.1.2 1.2.840.10008.1.2.1 1.2.840.10008.1.2.2	SCP	None
Digital Mammography Image Storage - For Presentation	1.2.840.10008.5.1.4.1.1.1.2	Implicit VR Little Endian Explicit VR Little Endian Explicit VR Big Endian	1.2.840.10008.1.2 1.2.840.10008.1.2.1 1.2.840.10008.1.2.2	SCP	None
Digital Mammography Image Storage - For Processing	1.2.840.10008.5.1.4.1.1.1.2.1	Implicit VR Little Endian Explicit VR Little Endian Explicit VR Big Endian	1.2.840.10008.1.2 1.2.840.10008.1.2.1 1.2.840.10008.1.2.2	SCP	None

CT Image Storage	1.2.840.10008.5.1.4.1.1.2	Implicit VR Little Endian Explicit VR Little Endian Explicit VR Big Endian	1.2.840.10008.1.2 1.2.840.10008.1.2.1 1.2.840.10008.1.2.2	SCP	None
Ultrasound Image Storage	1.2.840.10008.5.1.4.1.1.6.1	Implicit VR Little Endian Explicit VR Little Endian	1.2.840.10008.1.2 1.2.840.10008.1.2.1	SCP	None
Ultrasound Multi-frame Image Storage	1.2.840.10008.5.1.4.1.1.3.1	Implicit VR Little Endian Explicit VR Little Endian	1.2.840.10008.1.2 1.2.840.10008.1.2.1	SCP	None
MR Image Storage	1.2.840.10008.5.1.4.1.1.4	Implicit VR Little Endian Explicit VR Little Endian	1.2.840.10008.1.2 1.2.840.10008.1.2.1	SCP	None
NM Image Storage	1.2.840.10008.5.1.4.1.1.20	Implicit VR Little Endian Explicit VR Little Endian	1.2.840.10008.1.2 1.2.840.10008.1.2.1	SCP	None
PET Image Storage	1.2.840.10008.5.1.4.1.1.12 8	Implicit VR Little Endian Explicit VR Little Endian	1.2.840.10008.1.2 1.2.840.10008.1.2.1	SCP	None
RT Image Storage	1.2.840.10008.5.1.4.1.1.48 1.1	Implicit VR Little Endian Explicit VR Little Endian	1.2.840.10008.1.2 1.2.840.10008.1.2.1	SCP	None

2.9.1.1.2.2.1 SOP Specific DICOM Conformance Statement for All Storage SOP Classes

Following are the status codes that are more specifically processed when receiving messages from a **Storage** SCP equipment :

Service Status	Status Code	Further Meaning	Application Behavior When Receiving Status Code
Failure	A700-A7FF	Refused: Out of resources	Error logged for viewing in the Event Log.
	A900-A9FF	Error: Data Set does not match SOP Class	Error logged for viewing in the Event Log.

	C000-CFFF	Error: Cannot Understand	Error logged for viewing in the Event Log.
	0122	SOP Class Not Supported	Error logged for viewing in the Event Log.
Warning	B000	Coercion of Data Elements	Error logged for viewing in the Event Log.
	B006	Elements Discarded	Error logged for viewing in the Event Log.
	B007	Data Set does not match SOP Class	Error logged for viewing in the Event Log.
Success	0000		Success will be logged for viewing in the Event Log.
*	*	Any other status code.	Error logged for viewing in the Event Log.

2.9.1.1.3 Real-World Activity Image Print

2.9.1.1.3.1 Associated Real-World Activity

The user uses the Images screen to print selected images to a DICOM Printer.

2.9.1.1.3.2 Proposed Presentation Context Table

Presentation Context Table - Proposed by AE Elite Workstation for Activity Image Print					
Abstract Syntax		Transfer Syntax		Role	Extended Negotiation
Name	UID	Name List	UID List		
Basic Grayscale Print Management Meta SOP Class	1.2.840.10008.5.1.1.9	Implicit VR Little Endian	1.2.840.10008.1.2	SCU	None
		Explicit VR Little Endian	1.2.840.10008.1.2.1		
		Explicit VR Big Endian	1.2.840.10008.1.2.2		
Printer SOP Class	1.2.840.10008.5.1.1.16	Implicit VR Little Endian	1.2.840.10008.1.2	SCU	None
		Explicit VR Little Endian	1.2.840.10008.1.2.1		
		Explicit VR Big Endian	1.2.840.10008.1.2.2		

2.9.1.1.3.2.1 SOP Specific DICOM Conformance Statement for Basic Grayscale Print Management SOP Classes

The Elite Workstation uses the following DIMSE services of the supported SOP Classes:

SOP Class	SOP Class UID	DIMSE Service Element	SCU Usage
Basic Film Session	1.2.840.10008.5.1.1.1	N-CREATE	Used (Mandatory)
		N-SET	Not Used
		N-DELETE	Used
Basic Film Box	1.2.840.10008.5.1.1.2	N-CREATE	Used (Mandatory)
		N-ACTION	Used (Mandatory)
		N-DELETE	Used
		N-SET	Not Used
Basic Grayscale Image Box	1.2.840.10008.5.1.1.4	N-SET	Used (Mandatory)
Presentation LUT	1.2.840.10008.5.1.1.23	N-CREATE	Used (Mandatory)
		N-DELETE	Used
Printer	1.2.840.10008.5.1.1.16	N-EVENT-REPORT	Used (Mandatory)
		N-GET	Used

When a manual print operation is initiated, the AE:

1. Initiates a DICOM association and negotiates Presentation Contexts
2. N-GETs printer status using the Printer SOP Class
3. N-CREATES a Basic Film Session SOP Instance
4. N-CREATES the Presentation LUT for the images, based on Grayscale Presentation State for the images if one is present
5. N-CREATES a Basic Film Box SOP Instance for each film
6. N-SETs the Image Box SOP Instance for each image on the film
7. Prints by an N-ACTION on the Basic Film Box SOP Instance, followed by an N-DELETE of the Presentation LUT and Basic Film Session SOP Instance. If the SCP does not support collation and warning status B601 is returned for the N-ACTION session, the AE will ignore the warning. The AE only allows a single page print with multiple copies. Collation is not required but this is expected to create a print out.
8. Able to receive N-EVENT-REPORTs of the well known Printer SOP Instance indicating printer status
9. Performs an N-GET to obtain the printer status from the well known Printer SOP Instance
10. Releases the DICOM association after printing is successful or failure has been signalled to the user

The Elite Workstation includes data elements in the SOP Instances with associated value sets as described in sections 14.2, 0 and 0.

2.9.1.1.3.2.1.1 Basic Film Session SOP Class

Following are the status codes that are more specifically processed when receiving messages from a **Print** SCP equipment for the Basic Film Session SOP Class N-CREATE:

Service Status	Status Codes	Further Meaning	Application Behavior When receiving Status Codes
Failure	0106	Invalid attribute value	Error displayed to the user and logged for viewing in the Event Log.
	0213	Resource limitation	Error displayed to the user and logged for viewing in the Event Log.
Warning	B600	Memory allocation not supported	Warning logged for viewing in the Event Log.
Success	0000	Film session successfully created	Logged for viewing in the Event Log.
*	*	Any other status code.	Service log entry created.

The N-DELETE is used to delete the complete Basic Film Session SOP Instance hierarchy.

Following are the status codes that are more specifically processed when receiving messages from a **Print** SCP equipment for the Basic Film Session SOP Class N-DELETE:

Service Status	Status Codes	Further Meaning	Application Behavior When receiving Status Codes
Failure	0119	Class-instance conflict	No action is taken.
Success	0000	Film session successfully deleted	Successful log entry is created.
*	*	Any other status code.	No action is taken.

2.9.1.1.3.2.1.2 Basic Film Box SOP Class

Following are the status codes that are more specifically processed when receiving messages from a **Print** SCP equipment for the Basic Film Box SOP Class N-CREATE:

Service Status	Status Codes	Further Meaning	Application Behavior When receiving Status Codes
Failure	C616	There is an existing Film Box that has not been printed and N-ACTION at the Film Session level is not supported. A new Film Box will not be created when a previous Film Box has not been printed.	Error displayed to the user and logged for viewing in the Event Log.
Warning	B605	Requested Min Density or Max Density outside of printer's operating range. The printer will use its respective minimum or maximum density value instead.	Logged in the Event Log.
Success	0000	Film box successfully created	Successful log entry is created.

Service Status	Status Codes	Further Meaning	Application Behavior When receiving Status Codes
*	*	Any other status code.	Service log entry created.

The N-ACTION is used to print the Film Box, and return status is used to determine if print was successful

Following are the status codes that are more specifically processed when receiving messages from a **Print** SCP equipment for the Basic Film Box SOP Class N-ACTION:

Service Status	Status Codes	Further Meaning	Application Behavior When receiving Status Codes
Failure	C602	Unable to create Print Job SOP Instance; print queue is full	Error displayed to the user and logged for viewing in the Event Log.
	C603	Image size is larger than image box size (by using the specified magnification value)	Error displayed to the user and logged for viewing in the Event Log.
	C604	Image position collision : multiple images assigned to single image position	Error displayed to the user and logged for viewing in the Event Log.
	C613	Combined Print Image size is larger than the Image Box size	Error displayed to the user and logged for viewing in the Event Log.
Warning	B603	Film Box SOP Instance hierarchy does not contain Image Box SOP Instances (empty page)	Service log entry created.
	B604	Image size is larger than image box size, the image has been demagnified.	Service log entry created.
	B609	Image size is larger than the Image Box size. The Image has been cropped to fit.	Service log entry created.
	B60A	Image size or Combined Print Image size is larger than the Image Box size. Image or Combined Print Image has been decimated to fit.	Service log entry created.
Success	0000	Film accepted for printing; if supported, the Print Job SOP Instance is created	Successful log entry is created.
*	*	Any other status code.	Service log entry created.

N-SET is not used to update an instance of the Basic Film Box SOP Class.

The Elite Workstation does not use the N-DELETE to request the SCP to delete the Basic Film Box SOP Instance hierarchy.

2.9.1.1.3.2.1.3 Basic Grayscale Image Box SOP Class

The Elite Workstation will only send N-SET for the Grayscale Image Boxes the user has selected to have an image in Image Print operation. If layout is 2x2 and 3 images are queued, then three N-SET messages will be sent.

Following are the status codes that are more specifically processed when receiving messages from a **Print** SCP equipment for the Basic Grayscale Image Box SOP Class N-SET:

Service Status	Status Codes	Further Meaning	Application Behavior When receiving Status Codes
Failure	C603	Image size is larger than image box size	Error displayed to the user and logged for viewing in the Event Log.
	C605	Insufficient memory in printer to store the image	Error displayed to the user and logged for viewing in the Event Log.
	C613	Combined Print Image size is larger than the Image Box size	Error displayed to the user and logged for viewing in the Event Log.
Warning	B604	Image size larger than image box size, the image has been demagnified.	Service log entry created.
	B605	Requested Min Density or Max Density outside of printer's operating range. The printer will use its respective minimum or maximum density value instead.	Service log entry created.
	B609	Image size is larger than the Image Box size. The Image has been cropped to fit.	Service log entry created.
	B60A	Image size or Combined Print Image size is larger than the Image Box size. The Image or Combined Print Image has been decimated to fit.	Service log entry created.
Success	0000	Image successfully stored in Image Box	N/A
*	*	Any other status code.	Error displayed to the user and logged for viewing in the Event Log.

2.9.1.1.3.2.1.4 Printer SOP Class

The Elite Workstation supports the Printer SOP Class to receive information on the status of the printer.

For the product behavior description when receiving N-Event-Report request, refer to section 14.5.1 Printer N-Event-Report Attributes.

Following are the status codes the Application may send back in the **N-Event-Report** response command to the **Printer SOP Class** SCP Equipment that sent the N-Event-Report request:

Service Status	Status Code	Further Meaning	Status Code Explanation	Related Fields Sent Back to the SCU
Failure	*	Any status code.	Basic response to message.	None

Warning	*	Any status code.	Basic response to message	None
Success	0000		Basic response to message	None

The Elite Workstation uses the N-GET to request the SCP to get a Printer SOP Instance for the printer information.

For the attribute list requested by this product and for the behavior of this product on each returned value, refer to Section 14.5.2 Printer N-Get Attributes

Following are the status codes that are more specifically processed when receiving messages from a **Print** SCP equipment for the Printer SOP Class N-GET:

Service Status	Status Codes	Further Meaning	Application Behavior When receiving Status Codes
Failure	*	Any Failure status code	Displays an error to the user.
Success	0000	Success	Continues with the print.
*	*	Any other status code.	Displays an error to the user.

2.9.1.1.3.2.1.5 Presentation LUT SOP Class

The **Elite Workstation** supports the Presentation LUT SOP Class. The Presentation LUT will be sent to the Print SCP with Presentation LUT Shape of IDENTITY, assuming that the SCP supports the Presentation LUT SOP Class, this will result in a reference to the Presentatin LUT in the Basic Film Box N-CREATE.

2.9.1.2 Association Acceptance Policy

2.9.1.2.1 Real-World Activity Verify

2.9.1.2.1.1 Associated Real-World Activity- Verify

The Elite Workstation will respond to a Verify request from a remote SCU. There is no check for AE Title. Verify is to be used for network diagnostics after using the network tools 'ping' or 'traceroute' in order to determine if the port assignment is responding for Storage commit and Local Storage SCP.

2.9.1.2.1.2 Accepted Presentation Context Table

Presentation Context Table - Accepted by AE Elite Workstation for Activity Verify					
Abstract Syntax		Transfer Syntax		Role	Extended Negotiation
Name	UID	Name List	UID List		
Verification SOP Class	1.2.840.10008.1.1	Implicit VR Little Endian	1.2.840.10008.1.2	SCP	None

2.9.1.2.1.3 Presentation Context Acceptance Criterion

The Elite Workstation evaluates each Presentation Context independently, and accepts any Presentation Context that matches an Abstract Syntax for any Real-World Activity.

2.9.1.2.1.4 Transfer Syntax Selection Policies

Within each Presentation Context, the Elite Workstation will accept the first proposed transfer syntax that it also supports for that Abstract Syntax.

2.9.1.2.2 Real-World Activity- Storage Commit - SCP role

2.9.1.2.2.1 Associated Real-World Activity

For Image Send with Storage Commit, the Real-World Activity of Image Send to a DICOM Store/Commit server alias on the Elite Workstation will cause an association to be initiated from Storage Commitment SCP for the N-EVENT-REPORT.

2.9.1.2.2.2 Accepted Presentation Context Table

Presentation Context Table - Accepted by AE Elite Workstation for Activity - Storage Commit - SCP Role					
Abstract Syntax		Transfer Syntax		Role	Extended Negotiation
Name	UID	Name List	UID List		
Storage Commitment Push Model	1.2.840.10008.1.20.1	Implicit VR Little Endian Explicit VR Little Endian	1.2.840.10008.1.2 1.2.840.10008.1.2.1	SCP	None

2.9.1.2.2.2.1 SOP Specific DICOM Conformance Statement for the Storage Commitment Push Model SOP Class SCP

The Elite Workstation supports only DICOM network storage services to receive notification of SOP Instances which have been committed. It does not support the optional Storage Media File-Set ID and UID Attributes in the Storage Commitment N-ACTION.

Note - The Elite Workstation will not accept an N-Event-Report Request on the association requesting the Storage Commit. See section 2.3.1.2.4.2.

2.9.1.2.2.3 Presentation Context Acceptance Criterion

The Elite Workstation evaluates each Presentation Context independently, and accepts any Presentation Context that matches an Abstract Syntax for any Real-World Activity.

2.9.1.2.2.4 Transfer Syntax Selection Policies

Within each Presentation Context, the Elite Workstation will accept the first proposed transfer syntax that it also supports for that Abstract Syntax.

2.9.1.2.3 Real-World Activity Local Storage SCP

2.9.1.2.3.1 Associated Real-World Activity

The Elite Workstation will respond to storage requests which result from a Retrieve request from the system. The Elite Workstation will also allow storage of images which are directly sent to the Elite Workstation by an Image Store SCU.

2.9.1.2.3.2 Accepted Presentation Context Table

Presentation Context Table - Accepted by AE Elite Workstation for Activity Retrieve					
Abstract Syntax		Transfer Syntax		Role	Extended Negotiation
Name	UID	Name List	UID List		
Computed Radiography Image Storage	1.2.840.10008.5.1.4.1.1.1	Implicit VR Little Endian	1.2.840.10008.1.2	SCP	None
		Explicit VR Little Endian	1.2.840.10008.1.2.1		
		Explicit VR Big Endian	1.2.840.10008.1.2.2		
Digital X-Ray Image Storage – For Presentation	1.2.840.10008.5.1.4.1.2.2.1	Implicit VR Little Endian	1.2.840.10008.1.2	SCP	None
		Explicit VR Little Endian	1.2.840.10008.1.2.1		
		Explicit VR Big Endian	1.2.840.10008.1.2.2		
Digital X-Ray Image Storage – For Processing	1.2.840.10008.5.1.4.1.2.2.2	Implicit VR Little Endian	1.2.840.10008.1.2	SCP	None
		Explicit VR Little Endian	1.2.840.10008.1.2.1		
		Explicit VR Big Endian	1.2.840.10008.1.2.2		
Digital Mammography X-Ray Image Storage – For Presentation	1.2.840.10008.5.1.4.1.1.1.2	Implicit VR Little Endian	1.2.840.10008.1.2	SCP	None
		Explicit VR Little Endian	1.2.840.10008.1.2.1		
		Explicit VR Big Endian	1.2.840.10008.1.2.2		
Digital Mammography X-Ray Image Storage – For Processing	1.2.840.10008.5.1.4.1.1.1.2.1	Implicit VR Little Endian	1.2.840.10008.1.2	SCP	None
		Explicit VR Little Endian	1.2.840.10008.1.2.1		
		Explicit VR Big Endian	1.2.840.10008.1.2.2		
CT Image Storage	1.2.840.10008.5.1.4.1.1.2	Implicit VR Little Endian	1.2.840.10008.1.2	SCP	None
		Explicit VR Little Endian	1.2.840.10008.1.2.1		
		Explicit VR Big Endian	1.2.840.10008.1.2.2		
Ultrasound Multi-frame Image Storage	1.2.840.10008.5.1.4.1.1.3.1	Implicit VR Little Endian	1.2.840.10008.1.2	SCP	None
		Explicit VR Little Endian	1.2.840.10008.1.2.1		
		Explicit VR Big Endian	1.2.840.10008.1.2.2		
MR Image Storage	1.2.840.10008.5.1.4.1.1.4	Implicit VR Little Endian	1.2.840.10008.1.2	SCP	None
		Explicit VR Little Endian	1.2.840.10008.1.2.1		
		Explicit VR Big Endian	1.2.840.10008.1.2.2		
Ultrasound Image Storage	1.2.840.10008.5.1.4.1.1.6.1	Implicit VR Little Endian	1.2.840.10008.1.2	SCP	None
		Explicit VR Little Endian	1.2.840.10008.1.2.1		
		Explicit VR Big Endian	1.2.840.10008.1.2.2		
Secondary Capture Image Storage	1.2.840.10008.5.1.4.1.1.7	Implicit VR Little Endian	1.2.840.10008.1.2	SCP	None
		Explicit VR Little Endian	1.2.840.10008.1.2.1		
		Explicit VR Big Endian	1.2.840.10008.1.2.2		

Multi-frame Grayscale Byte SC Image Storage	1.2.840.10008.5.1.4.1.1.7.2	Implicit VR Little Endian	1.2.840.10008.1.2	SCP	None
		Explicit VR Little Endian	1.2.840.10008.1.2.1		
		Explicit VR Big Endian	1.2.840.10008.1.2.2		
X-Ray Angiographic Image Storage	1.2.840.10008.5.1.4.1.1.12.1	Implicit VR Little Endian	1.2.840.10008.1.2	SCP	None
		Explicit VR Little Endian	1.2.840.10008.1.2.1		
		Explicit VR Big Endian	1.2.840.10008.1.2.2		
X-Ray Radiofluoroscopic Image Storage	1.2.840.10008.5.1.4.1.1.12.2	Implicit VR Little Endian	1.2.840.10008.1.2	SCP	None
		Explicit VR Little Endian	1.2.840.10008.1.2.1		
		Explicit VR Big Endian	1.2.840.10008.1.2.2		
Nuclear Medicine Image Storage	1.2.840.10008.5.1.4.1.1.20	Implicit VR Little Endian	1.2.840.10008.1.2	SCP	None
		Explicit VR Little Endian	1.2.840.10008.1.2.1		
		Explicit VR Big Endian	1.2.840.10008.1.2.2		
Positron Emission Tomography (PET) Image Storage	1.2.840.10008.5.1.4.1.1.128	Implicit VR Little Endian	1.2.840.10008.1.2	SCP	None
		Explicit VR Little Endian	1.2.840.10008.1.2.1		
		Explicit VR Big Endian	1.2.840.10008.1.2.2		
RT Image Storage	1.2.840.10008.5.1.4.1.1.481.1	Implicit VR Little Endian	1.2.840.10008.1.2	SCP	None
		Explicit VR Little Endian	1.2.840.10008.1.2.1		
		Explicit VR Big Endian	1.2.840.10008.1.2.2		

2.9.1.2.3.2.1 SOP Specific DICOM Conformance Statement for all Storage SOP Classes

The Elite Workstation provides Level 2 (FULL) Conformance, and stores all standard and private data elements of received SOP Instances.

Successfully received SOP Instances may be accessed via the user interface. SOP Instances are stored for a configured time, which defaults to a value that retains images for three days, then they are automatically deleted. The timeout period can be modified by the user. The Elite Workstation will notify the user if the space allocated for the Local Store SCP is used and the user can manually delete exams at that time.

Following are the status codes the Application may send back to the SCU Equipment after performing the requested **Storage** :

Service Status	Status Code	Further Meaning	Status Code Explanation	Related Fields Sent Back to the SCU
Failure	A700	Refused: Out of resources	Returned when file system for external images is full.	None
	A900	Error: Data Set does not match SOP Class	Returned when the message SOP Class and dataset SOP Class do not match.	None

	C000	Error: Cannot Understand	Returned when the stored data can not be loaded as a DICOM dataset. Also when the Study and/or Series UIDs are not available.	None
Success	0000			None

2.9.1.2.3.3 Presentation Context Acceptance Criterion

The Elite Workstation evaluates each Presentation Context independently, and accepts any Presentation Context that matches an Abstract Syntax for any Real-World Activity.

2.9.1.2.3.4 Transfer Syntax Selection Policies

Within each Presentation Context, the Elite Workstation will accept the first proposed transfer syntax that it also supports for that Abstract Syntax.

2.10 COMMUNICATION PROFILES

2.10.1 Supported Communication Stacks

The DICOM Upper Layer Protocol is supported using TCP/IP, as specified in DICOM PS3.8.

The TCP/IP stack is inherited from the Linux Operating System.

2.10.2 Physical Media Support

The product is provided with a 10/100 Mb/s or 1Gb/s auto-sensing Ethernet interface. The OEC Elite also supports wireless networking.

Note: For more information about the Physical Media available on OEC Elite, please refer to the Product Data Sheet.

2.10.3 Additional Communication stack support

The Workstation supports DHCP allowing the user to configure DHCP from a System Setup screen. The default setting is to have DHCP enabled.

2.10.4 IPv4 and IPv6 Support

The Workstation supports IPv4. IPv6 is currently not supported.

2.11 EXTENSIONS / SPECIALIZATIONS/ PRIVATIZATIONS

2.11.1 Standard Extended / Specialized / Private SOP Classes

2.11.1.1 Standard Extended SOP Classes

The product provides Standard Extended Conformance to all supported SOP Classes, through the inclusion of additional Type 3 Standard Elements and Private Data Elements. The extensions for the RAW SOP Class (OEC Compatible) are defined in Section 3.5.1.

2.11.2 Private Transfer Syntaxes

No Private Transfer Syntax is supported.

2.12 CONFIGURATION

2.12.1 AE Title/Presentation Address Mapping

2.12.2 Configurable Parameters

The following fields are configurable for this AE (local):

- Local AE Title
- Local Station Name
- Local IP Address (DHCP or Static IP)
- Local Listening Port Number
- Local IP Netmask
- Default Gateway
- DNS server IP address
- Auto Negotiate (or set to specific speed and full/half duplex mode)

The following fields are configurable for every remote DICOM AE:

All Remote DICOM AE SCP: (Store/Storage Commit, Print, Modality Worklist, MPPS, Query/Retrieve)

- Server Alias
- Remote AE Title
- Remote IP Address or fully qualified host name
- Listening TCP/IP Port Number

The following fields are configurable:

- Association Establishment Timer - (this is doubled for inactivity on existing communication for Store).

Default Gateway of network connection used for all remote connections.

USB Options (Media Exchange)

- Modality to save (XA, RF, CR, SC. Default - XA)
- Image Size (Half, Full. Default - Full)
- Remove Patient Information (Default - No)

- Merge into one Overlay (Default – Yes)

Additional fields for Remote DICOM Store

- Modality to store (RF, XA, CR or SC. Default - XA)
- Image Size (Half, Full. Default – Full)
- Store Overlay(s) options (Always, If Annotated, Never. Default - Never)
- Merge Overlays (Default – Unchecked)
- Auto Store of RDSR on Exam completion(Default – Unchecked)

Additional fields for Remote DICOM Print

- Configuration information for Printer (see printer conformance statement for tag 2010,0150)
- Min/Max Density for Printer
- Ambient Illumination
- Reflective Ambient Light
- Border Density
- Empty Density
- Number of Copies
- Print Priority
- Destination
- Medium Type
- Film Size
- Format (Default 1,1)
- Bit Depth

Additional fields for Remote DICOM Query/Retrieve

- Information model (Patient, Study Root. Default is Patient Root)

Note: All configurations are accessible by the user to enable the mobility of the device. The configuration is also accessible to the GEHC Field Engineer.

Note: The use of TLS for all DICOM service can be enabled or disabled. This functionality is available only with the OEC Elite Secure option.

2.13 SUPPORT OF EXTENDED CHARACTER SETS

The OEC Elite will support the extended character set of ISO_IR 100 (Latin alphabet Number 1 supplementary set) for the characters supported on the keyboard.

As a Storage SCP or Media Storage FSR, the product will accept SOP Instances with ISO_IR 100 compatible values found in Specific Character Set (0008,0005). As a Query SCU, it will similarly accept response items with any value

of Specific Character Set. Compatible values to ISO_IR 100 are ISO_IR 6 and ISO_IR 100, according to the standard. Lack of the Specific Character set (0008,0005) tag is defined to be ISO_IR 6.

The product user interface will allow the user to enter characters from the console keyboard that are within ISO_IR 100 extended character set.

The product will accept, as a Modality Worklist SCU, Scheduled Procedure Step Identifiers with ISO_IR 100 compatible values of Specific Character Set (0008,0005). It will map that Specific Character Set value without change into the images created pursuant to that Scheduled Procedure Step. Text attributes of the Scheduled Procedure Step Identifier, including Patient and Physician names, that include extended characters will be displayed as described above. Responses with non-compatible values will be discarded.

2.14 CODES AND CONTROLLED TERMINOLOGY

2.14.1 Fixed Coded Terminology

The product uses the fixed (non-configurable, non-extensible) coded terminology in Image SOP Instance and X-Ray Radiation Dose Structured Report attributes, as described in Sections 9.7 where the VT is CODE. In these cases the standard or extended value for the code is defined .

2.14.2 Mapped Coded Terminology

The product maps, without change, coded terminology values supplied in Modality Worklist Scheduled Procedure Steps into Image SOP Instance and X-Ray Radiation Dose Structured Report attributes, as described in Sections 9.7 for RDSR and 10.4.1.2, 10.4.2, 10.4.3, and 10.4.5 for images.

2.15 SECURITY PROFILES

2.15.1 External Network Requirements

The following describes non-DICOM network protocols used by the OEC Elite to set the current time for the implementation and to obtain the network address for the implementation. The OEC Elite system has a single network interface that may be configured for secure communication with transport layer security, or for non-secure communication.

Profile	Actor	Transaction	Protocol Used	RFCs	Security Support
Basic Time Synchronization	NTP Client	Maintain Time	NTP	RFC5905 RFC5906	Yes
		Find NTP Servers	NTP	RFC5905 RFC5906	Yes
	SNTP Client	Maintain Time	SNTP	RFC2030	No
	DHCP Client	Find NTP Servers	DHCP	RFC2131 RFC2132	Yes
Basic Network Address Management	DHCP Client	Find and Use DHCP Server	DHCP	RFC2131 RFC2132	Yes
		Maintain Lease	DHCP	RFC2131 RFC2132	Yes
	DNS Client	Resolve Hostname	DNS	RFC1035 RFC2181	Yes

2.15.2 Secure Transport Connection Profiles

Note: This section pertains only to systems with the OEC Elite Secure option.

The OEC Elite Secure option’s certificate management allows:

- Creating a private key and creating and exporting self-signed certificates
- Creating a private key and exporting a corresponding certificate signing request
- Importing a signed host certificate and, optionally, a private key. Passphrase protected keys may be imported and are unlocked prior to storage on the system.
- Importing trusted certificates for servers and certificate authorities.
- Using only PEM-encoded keys and certificate

The following describes secure transport connection profiles used by the OEC Elite.

Profile	Cipher Suite	Default Preference Order (from 1=preferred to 6=less preferred)
Non-Downgrading BCP195 TLS Secure Transport Connection	TLS_DHE_RSA_WITH_AES_128_GCM_SHA256	1
	TLS_ECDHE_RSA_WITH_AES_128_GCM_SHA256	2
	TLS_DHE_RSA_WITH_AES_256_GCM_SHA384	3
	TLS_ECDHE_RSA_WITH_AES_256_GCM_SHA384	4

Profile	Cipher Suite	Default Preference Order (from 1=preferred to 6=less preferred)
AES TLS Secure Transport Connection	TLS_RSA_WITH_AES_128_CBC_SHA	5
	TLS_RSA_WITH_3DES_EDE_CBC_SHA	6

2.15.3 Secured Environment

It is assumed that the product is used within a secured environment. It is assumed that a secured environment includes at a minimum:

1. Firewall or router protections to ensure that only approved external hosts have network access to the product.
2. Firewall or router protections to ensure that the product only has network access to approved external hosts and services.
3. Any communications with external hosts and services outside the locally secured environment use appropriate secure network channels (such as a Virtual Private Network (VPN)) or secured ports like HTTPS (443).

3. MEDIA STORAGE CONFORMANCE STATEMENT

3.1 INTRODUCTION

This section of the DICOM conformance statement specifies the OEC Elite compliance to DICOM requirements for **Media Interchange**. It details the DICOM Media Storage Application Profiles and roles that are supported by this product.

The Elite Workstation is able to export images to DICOM media, browse DICOM media and read images from DICOM media.

3.2 IMPLEMENTATION MODEL

3.2.1 Application Data Flow Diagram

The media interchange application model for the OEC Elite is shown in the following Illustration :

ILLUSTRATION 3-1
OEC ELITE MEDIA INTERCHANGE APPLICATION MODEL AND DATA FLOW DIAGRAM

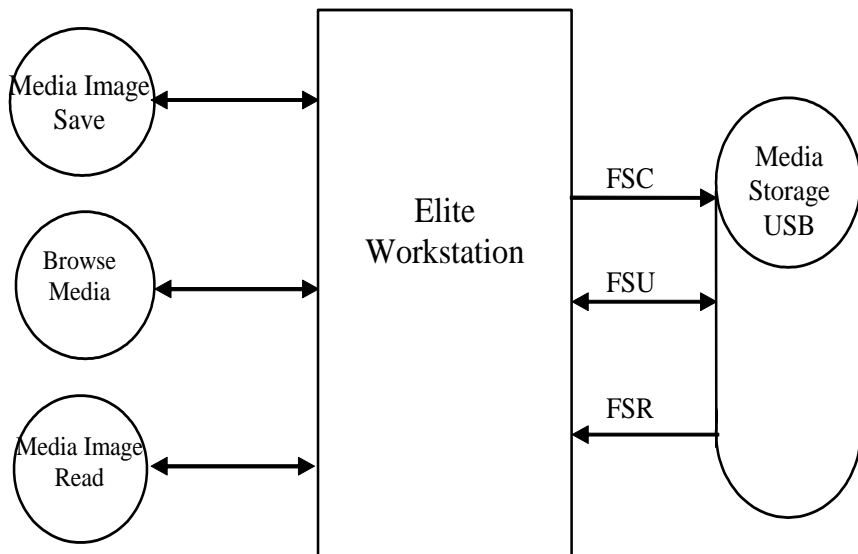

The product supports Media Storage Application Profile of General Purpose USB Interchange(STD-GEN-USB) with no compression.

3.2.2 Functional Definition of AE's

The Elite Workstation can perform these functions:

FSC, FSU and FSR function on a list of SOP Image Classes. The list of image classes supported can be found in section 2.9.1.2.3.2. The Elite Workstation also allows OEC Compatible images to be written and read back.

3.2.3 Sequencing of Real-World Activities

The Elite Workstation performs Media Image Write (FSC/FSU) when sending copies of the selected images, Dose summary, Patient Summary or Radiation Dose Structured Report from the Images screen.

The Elite Workstation performs Browse Media (FSR) when the user is searching the media (USB) using the Retrieve screen.

The Elite Workstation performs Media Read (FSR) when the user copies images (DICOM or OEC Compatible) from the media to the system.

3.2.4 File Meta Information Options (See PS3.10)

The File Meta-Information for this implementation is :

File Meta-Information Version	1
Elite Workstation Implementation UID	1.2.840.113619.9.329
Implementation Version Name	OEC ELITE v1.1

3.3 AE SPECIFICATIONS

3.3.1 Elite Workstation AE Specification

The Elite Workstation Application Entity provides standard conformance to DICOM Interchange Option of the Media Storage Service Class. The supported Application Profiles and roles are listed below.

Supported Application Profile	Real World Activity	Role	Option
STD-GEN-USB	Media Image Save	FSC+FSU	Interchange
	Browse Media and Media Image Read	FSR	Interchange
STD-GEN-USB-JPEG	Browse Media	FSR	Interchange
	Media Image Read	FSR	Interchange

3.3.1.1 File Meta Information for the Elite Workstation Application Entity

Following are the values set in the File Meta Information for this AE Title :

Source Application Entity Title	Value configured by the user on the Local Server Definition screen for DICOM.
Elite Workstation Implementation UID	1.2.840.113619.9.329
Implementation Version Name	OEC ELITE v1.1

Note – No private tags are added to the File Meta Information for this AE Title.

3.3.1.2 Real-World Activities for the Elite Workstation Application Entity

3.3.1.2.1 Real-World Activity- Media Image Save

The user loads/mounts a USB device into the Elite Workstation using the Load USB control on the Images screen. The user then selects the images to copy and then selects the Send control to send them to the USB device. The Options control allows the user to change the SOP Class that will be written to USB.

3.3.1.2.1.1 Media Storage Application Profile for the RWA- Media Image Save

For the list of Application Profiles that invoke this AE for the Real-World Activity Media Image Save, see the Table in Section 3.3.1, where the table describing the Application Profiles and Real-World Activity is defined.

3.3.1.2.1.1.1 Options for STD-GEN-USB Application Profile

Following are the optional SOP Classes supported by this AE. All SOP Instances use the Explicit VR Little Endian Uncompressed Transfer Syntax, UID 1.2.840.10008.1.2.1.

SOP Class	SOP Class UID
Computed Radiography Image Storage	1.2.840.10008.5.1.4.1.1.1
Secondary Capture Image Storage	1.2.840.10008.5.1.4.1.1.7
Multi-frame Grayscale Byte SC Image Storage	1.2.840.10008.5.1.4.1.1.7.2
X-Ray Angiographic Image Storage	1.2.840.10008.5.1.4.1.1.12.1
X-Ray Radiofluoroscopic Image Storage	1.2.840.10008.5.1.4.1.1.12.2
Raw Data Storage	1.2.840.10008.5.1.4.1.1.66
X-Ray Radiation Dose SR Storage	1.2.840.10008.5.1.4.1.1.88.67

Common DICOMDIR Directory Records created by this AE will include key attributes as described in Section 13.2.3.

No additional DICOMDIR Keys are added to any record types.

|

3.3.1.2.1.1.2 Options for STD-GEN-USB-JPEG Application Profile

No additional SOP Classes / Transfer Syntaxes supported by this AE for Media Image Save.

3.3.1.2.2 Real-World Activity- Browse Media

The user loads/mounts a USB device into the Elite Workstation using the Load USB control on the Images screen. The user then selects the USB device to View the contents from the Images screen, this action starts the Retrieve screen where the user can browse the media.

3.3.1.2.2.1 Media Storage Application Profile for the RWA - Browse Media & Media Image Read

For the list of Application Profiles that invoke this AE for the Real-World Activity Browse Media and Media Image Read, see the Table in Section 3.3.1, where the table describing the Application Profiles and Real-World Activity is defined.

3.3.1.2.2.1.1 Options for STD-GEN-USB Application Profile

Following are the optional SOP Classes supported by this AE. All SOP Instances use the Explicit VR Little Endian Uncompressed Transfer Syntax, UID 1.2.840.10008.1.2.1.

SOP Class	SOP Class UID
Computed Radiography Image Storage	1.2.840.10008.5.1.4.1.1.1
Digital X-Ray Image Storage - For Presentation	1.2.840.10008.5.1.4.1.1.1.1
Digital X-Ray Image Storage - For Processing	1.2.840.10008.5.1.4.1.1.1.1.1
Digital Mammography Image Storage - For Presentation	1.2.840.10008.5.1.4.1.1.1.2
Digital Mammography Image Storage - For Processing	1.2.840.10008.5.1.4.1.1.1.2.1
CT Image Storage	1.2.840.10008.5.1.4.1.1.2
Ultrasound Multi-frame Image Storage	1.2.840.10008.5.1.4.1.1.3.1
MR Image Storage	1.2.840.10008.5.1.4.1.1.4
Ultrasound Image Storage	1.2.840.10008.5.1.4.1.1.6.1
Secondary Capture Image Storage	1.2.840.10008.5.1.4.1.1.7
Multi-frame Grayscale Byte SC Image Storage	1.2.840.10008.5.1.4.1.1.7.2
X-Ray Angiographic Image Storage	1.2.840.10008.5.1.4.1.1.12.1
X-Ray Radiofluoroscopic Image Storage	1.2.840.10008.5.1.4.1.1.12.2
Nuclear Medicine Image Storage	1.2.840.10008.5.1.4.1.1.20
Raw Data Storage (1)	1.2.840.10008.5.1.4.1.1.66
RT Image Information Storage	1.2.840.10008.5.1.4.1.1.481.1
Positron Emission Tomography (PET) Image Storage	1.2.840.10008.5.1.4.1.1.128

Note 1: Raw Data Storage is used for OEC Compatible data which can be used to move an exam to another system and preserve the image processing manipulation possible on acquired images.

Common DICOMDIR Directory Records created by this AE will include key attributes as described in Section 13.2.3.

No additional DICOMDIR Keys are added to any record types.

3.3.1.2.2.1.2 Options for STD-GEN-USB-JPEG Application Profile

Following are the optional SOP Classes / Transfer Syntaxes supported by this AE.

SOP Class	SOP Class UID	Transfer Syntax	Transfer Syntax UID	Profile
See table in section 3.3.1.2.2.1.1 exception: Raw Data Storage	See table in section 3.3.1.2.2.1.1	RLE Lossless	1.2.840.10008.1.2.5	JPEG
		JPEG Lossy, Baseline Sequential with Huffman Coding (Process 1)	1.2.840.10008.1.2.4.50	JPEG

	JPEG Extended (Process 2 & 4): Default Transfer Syntax for Lossy JPEG 12 Bit Image Compression (Process 4 only)	1.2.840.10008.1.2.4.51	JPEG
	JPEG Lossless, Non-hierarchical, Process 14	1.2.840.10008.1.2.4.57	JPEG
	JPEG Lossless, Non-hierarchical, 1st Order Prediction	1.2.840.10008.1.2.70	JPEG

Common DICOMDIR Directory Records created by this AE will include key attributes as described in Section 13.2.3.

No additional DICOMDIR Keys are added to any record types.

3.4 AUGMENTED AND PRIVATE APPLICATION PROFILES

3.4.1 Augmented Application Profiles

The Elite Workstation uses private tags to store information in the Raw Data Storage SOP Class to allow for the image to be restored to the system for image processing.

3.4.1.1 Augmented Application Profile AUG-GEN-USB-OEC

The AUG-GEN-USB-OEC Application Profile is an augmentation of the corresponding STD-GEN-USB Profile. This application profile allows for the export and import of images between systems.

3.5 EXTENSIONS / SPECIALIZATIONS / PRIVATIZATIONS

3.5.1 Standard Extended / Specialized / Private SOP Classes

3.5.1.1 Standard Extended SOP Classes

The product provides Standard Extended Conformance to all supported SOP Classes, through the inclusion of additional Type 3 Elements. The extensions are defined in Sections 4.5

3.5.1.2 Private Creator Groups

The following private creator groups are added to the Raw Data SOP class instance alone. No other SOP class will have these groups.

Element Name	Tag	VR	VM	Description
Private Creator	0071,0010	LO	1	OEC specific data
Private Creator	1001,0010	SL	1	OEC specific data
Private Creator	1003,0010	SL	1	OEC specific data
Private Creator	1005,0010	SL	1	OEC specific data

Private Creator	1007,0010	SL	1	OEC specific data
Private Creator	1009,0010	SL	1	OEC specific data
Private Creator	100B,0010	SL	1	OEC specific data
Private Creator	100D,0010	SL	0-1	OEC specific data
Private Creator	100F,0010	SL	1	OEC specific data
Private Creator	1F01,0010	SL	1	OEC specific data
Private Creator	1101,0010	SL	1	OEC specific data
Private Creator	1103,0010	SL	1	OEC specific data
Private Creator	1105,1000	SL	1	OEC specific data
Private Creator	1109,0010	SL	1	OEC specific data

3.6 CONFIGURATION

The following parameters are configurable by the user and :

- Source Application Entity Title – This is the AE Title on the Local Server Definition screen.

3.7 SUPPORT OF EXTENDED CHARACTER SETS

The Elite Workstation only supports ISO_IR 100. Any incoming SOP instance that is encoded using another extended character set will not be read, browse operations will also not display entries.

4. X-RAY ANGIOGRAPHIC INFORMATION OBJECT IMPLEMENTATION

4.1 INTRODUCTION

This section specifies the use of the DICOM X-Ray Angiographic Image IOD to represent the information included in X-Ray Angiographic Images produced or received by this implementation. Corresponding attributes are conveyed using the module construct.

4.2 OEC ELITE MAPPING OF DICOM ENTITIES

The OEC Elite maps DICOM Information Entities to local Information Entities in the product’s database and user interface.

TABLE 4-1
MAPPING OF DICOM ENTITIES TO OEC ELITE ENTITIES

DICOM IE	OEC Elite Entity
Patient	Patient
Study	Exam
Series	Series
Image	Image

4.3 IOD MODULE TABLE

The X-Ray Angiographic Image Information Object Definition comprises the modules of the following table, plus Standard Extended and Private attributes. Standard Extended and Private attributes are described in Section 4.5.

TABLE 4-2
X-RAY ANGIOGRAPHIC IMAGE IOD MODULES

Entity Name	Module Name	Usage	Reference
Patient	Patient	Used	4.4.1.1
	Clinical Trial Subject	Not Used	N/A
Study	General Study	Used	4.4.2.1
	Patient Study	Used when the data is passed by the Modality Worklist.	4.4.2.2
	Clinical Trial Study	Not Used	N/A
Series	General Series	Used	4.4.3.1
	Clinical Trial Series	Not Used	N/A
Frame of Reference	Synchronization	Not Used	N/A
Equipment	General Equipment	Used	4.4.4.1
Image	General Image	Used	4.4.5.1

Entity Name	Module Name	Usage	Reference
	General Reference	Not Used	N/A
	Image Pixel	Used	4.4.5.2
	Contrast/Bolus	Present Required if contrast media was used in this image, the system does not presently know if contrast was used or not.	4.4.5.3
	Cine	Used when image is multi-frame.	4.4.5.11
	Multi-frame	Used when image is multi-frame.	4.4.5.13
	Frame Pointers	Used when image is multi-frame.	4.4.5.14
	Mask	Used when image is Subtract mode image	4.4.5.12
	Display Shutter	Not Used	N/A
	Device	Not Used	N/A
	Intervention	Not Used	N/A
	Specimen	Not Used	N/A
	X-Ray Image	Used	4.4.5.4
	X-Ray Acquisition	Used	4.4.5.5
	X-Ray Collimator	Not Used	N/A
	X-Ray Table	Not Used	N/A
	XA Positioner	Used	4.4.5.6
	DX Detector	Used	4.4.5.7
	Overlay Plane	Used when the user specifies the overlay to be stored for a DICOM Store and used in Media.	4.4.5.8
	Multi-Frame Overlay	Not Used	N/A
	Modality LUT	Not Used	N/A

Entity Name	Module Name	Usage	Reference
	VOI LUT	Used to provide the Window Width and Center for the image.	4.4.5.9
	SOP Common	Used	4.4.5.10
	Common Instance Reference	Not Used	N/A
	Frame Extraction	Not Used	N/A

4.4 INFORMATION MODULE DEFINITIONS

Please refer to DICOM Part 3 (Information Object Definitions) for a description of each of the entities, modules, and attributes contained within the X-Ray Angiographic Information Object.

The following modules are included to convey Enumerated Values, Defined Terms, and Optional Attributes supported. Type 1 & Type 2 Attributes are also included for completeness and to define what values they may take and where these values are obtained from when generating the instance. It should be noted that they are the same ones as defined in the DICOM Standard Part 3 (Information Object Definitions). Also note that Attributes not present in tables are not supported.

4.4.1 Patient Entity Modules

4.4.1.1 Patient Module

**TABLE 4-3
PATIENT MODULE ATTRIBUTES**

Attribute Name	Tag	Type	Attribute Description
Patient's Name	(0010,0010)	2	Provided by the MWL or supplied by user input. The value is created by the system if not entered by the user as an emergency exam name. The prefix of the name is configurable by the user and has an incrementing number appended.
Patient ID	(0010,0020)	2	Provided by the MWL or supplied by user input. The value is created by the system if not entered by the user as an emergency exam ID. The prefix of the ID is configurable by the user and has an incrementing number appended.
Issuer of Patient ID	(0010,0021)	3	Provided by the MWL. No user interface on the product.
Issuer of Patient ID Qualifiers Sequence	(0010,0024)	3	Provided by the MWL. No user interface on the product.
Patient's Birth Date	(0010,0030)	2	Provided by the MWL or supplied by user input.
Patient's Sex	(0010,0040)	2	Provided by the MWL or supplied by user input.
Patient Comments	(0010,4000)	3	Provided by user input.

Attribute Name	Tag	Type	Attribute Description
De-identification Method	(0012,0063)	1C	Set to NO unless Media Image Save is performed with de-identification.
De-identification Method Code Sequence	(0012,0064)	1C	Set to the 'Basic Application Confidential Profile' value when Media Image Save is performed with de-identification.

4.4.2 Study Entity Modules

4.4.2.1 General Study Module

TABLE 4-4
GENERAL STUDY MODULE ATTRIBUTES

Attribute Name	Tag	Type	Attribute Description
Study Instance UID	(0020,000D)	1	Provided by the MWL or supplied by the system.
Study Date	(0008,0020)	2	Set when the exam is started on the system.
Study Time	(0008,0030)	2	Set when the exam is started on the system.
Referring Physician's Name	(0008,0090)	2	Provided by the MWL or supplied by user input.
Study ID	(0020,0010)	2	Provided by the MWL or supplied by user input or created by system.
Accession Number	(0008,0050)	2	Provided by the MWL or supplied by user input.
Study Description	(0008,1030)	3	Provided by the MWL or supplied by user input.
Referenced Study Sequence	(0008,1110)	3	Provided by the MWL and used to allow for quick query/retrieval of referenced Studies.
Procedure Code Sequence	(0008,1032)	3	Provided by the MWL or supplied by user input.

4.4.2.2 Patient Study Module

TABLE 4-5
PATIENT STUDY MODULE ATTRIBUTES

Attribute Name	Tag	Type	Attribute Description
Patient's Age	(0010,1010)	3	Provided by the MWL or calculated by the system based on the birth date.
Patient's Size	(0010,1020)	3	Provided by the MWL.
Patient's Weight	(0010,1030)	3	Provided by the MWL.

4.4.3 Series Entity Modules

4.4.3.1 General Series Module

**TABLE 4-6
GENERAL SERIES MODULE ATTRIBUTES**

Attribute Name	Tag	Type	Attribute Description
Modality	(0008,0060)	1	Defined by the user by setting the modality on the DICOM Server or Media Image Save.
Series Instance UID	(0020,000E)	1	Created by the system.
Series Number	(0020,0011)	2	Created by the system.
Laterality	(0020,0060)	2C	Blank, unless the user adds a Marker annotation to the image containing only a 'R' or 'L'.
Series Date	(0008,0021)	3	Set to the date the exam was started.
Series Time	(0008,0031)	3	Set to the time the exam was started.
Performing Physicians' Name	(0008,1050)	3	Provided by the MWL or supplied by user input.
Protocol Name	(0018,1030)	3	Provided by the MWL or supplied by user input.
Series Description	(0008,103E)	3	Provided by the MWL or supplied by user input. Found on the Additional Information screen and labeled as the Protocol Description.
Patient Position	(0018,5100)	2C	Derived from the values set by the user on the Additional Information screen. The values are Patient Orientation, Orientation Modifier and Patient/Table Relationship.
Request Attributes Sequence	(0040,0275)	3	Sequence set with values from the MWL. No user input is used.
>Requested Procedure ID	(0040,1001)	1C	Value from MWL.
>Accession Number	(0008,0050)	3	Value from MWL.
>Study Instance UID	(0020,000D)	3	Value from MWL.
>Requested Procedure Description	(0032,1060)	3	Value from MWL.
>Scheduled Procedure Step ID	(0040,0009)	1C	Value from MWL.
>Scheduled Procedure Step Description	(0040,0007)	3	Value from MWL.
>Scheduled Protocol Code Sequence	(0040,0008)	3	Value from MWL.
Performed Procedure Step ID	(0040,0253)	3	Value from MWL or value entered by the user or created by the system if blank.
Performed Procedure Step Start Date	(0040,0244)	3	Set to the date the exam was started.
Performed Procedure Step Start Time	(0040,0245)	3	Set to the time the exam was started.
Performed Procedure Step Description	(0040,0254)	3	Value from MWL or value entered by the user.
Performed Protocol Code Sequence	(0040,0260)	3	Value from MWL.

4.4.4 Equipment Entity Modules

4.4.4.1 General Equipment Module

TABLE 4-7
GENERAL EQUIPMENT MODULE ATTRIBUTES

Attribute Name	Tag	Type	Attribute Description
Manufacturer	(0008,0070)	2	Taken from the System value. Not editable by the user.
Institution Name	(0008,0080)	3	Value input by the user on the Regional Settings screen.
Station Name	(0008,1010)	3	Value input by the user on the DICOM Local settings screen.
Manufacturer's Model Name	(0008,1090)	3	Taken from the System value. Not editable by the user.
Device Serial Number	(0018,1000)	3	Taken from the System value. Not editable by the user.
Software Versions	(0018,1020)	3	Taken from the System value. Not editable by the user.
Date of Last Calibration	(0018,1200)	3	Taken from the System value. Value is the Dose Accuracy Calibration Date/time.
Time of Last Calibration	(0018,1201)	3	Taken from the System value. Value is the Dose Accuracy Calibration Date/time.

4.4.5 Image Entity Modules

4.4.5.1 General Image Module

TABLE 4-8
GENERAL IMAGE MODULE ATTRIBUTES

Attribute Name	Tag	Type	Attribute Description
Instance Number	(0020,0013)	2	The system starts numbering images at 1 and increments by 1 until the exam is completed.
Patient Orientation	(0020,0020)	2C	See 4.4.5.1.1.
Content Date	(0008,0023)	2C	Set to the date/time the image was last saved.
Content Time	(0008,0033)	2C	Set to the date/time the image was last saved.
Image Type	(0008,0008)	3	See 4.4.5.4.1
Acquisition Number	(0020,0012)	3	Set to the number of the irradiation event that created this image.
Acquisition Date	(0008,0022)	3	Set to the date/time of the irradiation event that created this image.
Acquisition Time	(0008,0032)	3	Set to the date/time of the irradiation event that created this image.
Acquisition DateTime	(0008,002A)	3	Set to the date/time of the irradiation event that created this image.

Attribute Name	Tag	Type	Attribute Description
Derivation Description	(0008,2111)	3	See 4.4.5.1.2.
Source Image Sequence	(0008,2112)	3	See 4.4.5.1.2.
Irradiation Event UID	(0008,3010)	3	Unique identification of the irradiation event associated with the acquisition of this image.
Burned In Annotation	(0028,0301)	3	Set to NO.
Lossy Image Compression	(0028,2110)	3	See 4.4.5.1.3.
Icon Image Sequence	(0088,0200)	3	See section for the Icon Image Key Definition.
>Include 'Image Pixel Macro'		See 4.4.5.1.4	
Presentation LUT Shape	(2050,0020)	3	Set to IDENTITY

4.4.5.1.1 Patient Orientation

This value will always be set the ""(blank), since the system can not get the information from the data input by the user at this time.

4.4.5.1.2 Derivation Description and Source Image Sequence

This value will be set to "Zoomed instance. See Source Image Sequence for source image". This value will be set to "Single Frame from Cine. See Source Image Sequence for source image", when the image is derived from a source Cine run. This value will be set to "Cine run incomplete. All images were not stored. There is no Source Image Sequence for this partial image.", when the system detects that all frames for a cine acquire were not stored.

4.4.5.1.3 Lossy Image Compression

This value will be set to '00': Image has NOT been subjected to lossy compression.

4.4.5.1.4 Icon Image Key Definition

The Icon Image Sequence is always saved. Describe:

- The Samples per Pixel (0028,0002) is always set to 1,
- Photometric Interpretations (0028,0004) is set to MONOCHROME 2,
- Row/Column size is 64 by 64,
- The value of 8 is set for Bits Allocated (0028,0100) and Bits Stored (0028,0101),
- The value of 7 is set for HighBit (0028,0102).
- The value of 0 is set for PixelRepresentation (0028,0103)

4.4.5.2 Image Pixel Module

This table covers other modalities besides XA specific attributes describe this in the Attribute Description.

TABLE 4-9
IMAGE PIXEL MODULE ATTRIBUTES

Attribute Name	Tag	Type	Attribute Description
Samples per Pixel	(0028,0002)	1	This value is set to 1.

Attribute Name	Tag	Type	Attribute Description
Photometric Interpretation	(0028,0004)	1	This value is set to MONOCHROME2
Rows	(0028,0010)	1	This value is set to 1280 for Full Size and 640 for half size image stored. SC modality can only be stored as 1280 which includes Multi-frame Grayscale Byte SC.
Columns	(0028,0011)	1	This value is set to 1280 for Full Size and 640 for half size image stored. SC modality can only be stored as 1280 which includes Multi-frame Grayscale Byte SC.
Bits Allocated	(0028,0100)	1	The value of 16 is used for XA, RF and CR modalities. SC modality uses 8 which includes Multi-frame Grayscale Byte SC.
Bits Stored	(0028,0101)	1	The value of 10 is used for XA, RF and CR modalities. SC modality uses 8 which includes Multi-frame Grayscale Byte SC.
High Bit	(0028,0102)	1	The value of 9 is used for XA, RF and CR modalities. SC modality uses 7 which includes Multi-frame Grayscale Byte SC.
Pixel Representation	(0028,0103)	1	This value is set to 0000H.
Pixel Data	(7FE0,0010)	1	Pixel data of the image.

4.4.5.3 Contrast/Bolus Module

This table covers other modalities besides XA specific attributes describe this in the Attribute Description.

**TABLE 4-10
CONTRAST/BOLUS MODULE ATTRIBUTES**

Attribute Name	Tag	Type	Attribute Description
Contrast/Bolus Agent	(0018,0010)	2	Always blank. Applies to XA, RF and CR modalities only.
Contrast/Bolus Start Time	(0018,1042)	3	Only available on multi-frame images which have an injector signal.

4.4.5.4 X-Ray Image Module

This table covers other modalities besides XA specific attributes describe this in the Attribute Description.

**TABLE 4-11
X-RAY IMAGE MODULE ATTRIBUTES**

Attribute Name	Tag	Type	Attribute Description
Lossy Image Compression	(0028,2110)	1C	See 4.4.5.1.3. Present only in XA and RF modalities.
Image Type	(0008,0008)	1	See 4.4.5.4.1
Pixel Intensity Relationship	(0028,1040)	1	Set to the value of "DISP". Present only in XA and RF modalities.

Attribute Name	Tag	Type	Attribute Description
Samples per Pixel	(0028,0002)	1	Value is 1
Photometric Interpretation	(0028,0004)	1	Value is MONOCHROME2
Bits Allocated	(0028,0100)	1	The value of 16 is used for XA, RF and CR modalities. SC modality uses 8.
Bits Stored	(0028,0101)	1	The value of 10 is used for XA, RF and CR modalities. SC modality uses 8.
High Bit	(0028,0102)	1	The value of 9 is used for XA, RF and CR modalities. SC modality uses 7.
Pixel Representation	(0028, 0103)	1	Value is 0000H
Anatomic Region Sequence	(0008,2218)	3	Currently only supported in CR modality. Value is set by the user.

4.4.5.4.1 Image Type

Define the values of Image Type (0008,0008) that may be sent and under what circumstances, or refer to the more general description in the General Image Module.

Value 1 shall have the following Enumerated Values:

- ORIGINAL identifies an Original Image
- DERIVED identifies a Derived Image

Value 2 shall have the following Enumerated Value:

- PRIMARY identifies a Primary Image

Only the Enumerated Value SINGLE PLANE for Value 3 is supported:

4.4.5.5 X-Ray Acquisition Module

This table covers other modalities besides XA specific attributes describe this in the Attribute Description.

**TABLE 4-12
X-RAY ACQUISITION MODULE**

Attribute Name	Tag	Type	Attribute Description
KV	(0018,0060)	2	Set to the average value of the x-ray exposure.
Radiation Setting	(0018,1155)	1	All X-Ray modes send 'SC' except for Digital Spot and Digital Cine which sends 'GR'. This tag is only present for XA and RF modalities.
X-Ray Tube Current	(0018,1151)	2C	The average value for the irradiation event is reported. The value is the ceiling of the decimal number of the current since this tag is an integer. Present in XA, RF and CR modalities.
X-Ray Tube Current in microA	(0018,8151)	3	The average value for the irradiation event is reported. Present in XA, RF and CR modalities.

Attribute Name	Tag	Type	Attribute Description
Exposure Time	(0018,1150)	2C	The time is reported as the ceiling of the milliseconds for this irradiation event. For pulsed mode irradiation events, only the pulsed irradiations are counted. There is a single continuous mode scout irradiation which is not counted with this value. This tag is present in XA, RF and CR modalities.
Exposure Time in microS	(0018,8150)	3	The time is reported as the microseconds for this irradiation event. For pulsed mode irradiation events, only the pulsed irradiations are counted. There is a single continuous mode scout irradiation which is not counted with this value. This tag is present in XA, RF and CR modalities.
Exposure	(0018,1152)	2C	The exposure is reported as the ceiling of the mAs for this irradiation event. For pulsed mode irradiation events, only the pulsed irradiations are counted. There is a single continuous mode scout irradiation which is not counted with this value. This tag is present in XA, RF and CR modalities.
Exposure in microAs	(0018,1153)	3	The exposure is reported as microAs for this irradiation event. For pulsed mode irradiation events, only the pulsed irradiations are counted. There is a single continuous mode scout irradiation which is not counted with this value. This tag is present in XA, RF and CR modalities.
Grid	(0018,1166)	3	The value reported is 'IN' when the grid is present for the irradiation event which created this image. The value is 'NONE' when the grid is not present for the irradiation event. This tag is present for XA and RF modalities only.
Average Pulse Width	(0018,1154)	3	This is the commanded value in milliseconds for the pulse mode irradiation event. This tag is present when the radiation mode is PULSED and XA or RF modalities only.
Radiation Mode	(0018,115A)	3	The value reported will be 'CONTINUOUS' for all X-Ray modes except pulsed mode which will report 'PULSED'. This tag is present for XA and RF modalities.
Intensifier Size	(0018,1162)	3	Diameter of X-Ray intensifier in mm when Image intensifier system is used. Not present on FPD based systems.
Imager Pixel Spacing	(0018,1164)	3	This value is only present for XA and RF modalities. Value is the detector pixel spacing in mm. Pixel Spacing = Row Spacing \ Column Spacing.

Attribute Name	Tag	Type	Attribute Description
Pixel Spacing	(0028,0030)	1C	This value is only present if the user has added measurements to the image and calibrated that measurement.
Image and Fluoroscopy Area Dose Product	(0018,115E)	3	Present in XA and RF only. Value is in dGym2. Value is blank or 0.0 in DERIVED images.
Entrance Dose	(0040,0302)	3	Entrance dose measured in dGy at the system reference point for this image. This is an unsigned integer which will round the value and may be zero.
Entrance Dose in mGy	(0040,8302)	3	Entrance dose measured in mGy at the system reference point for this image. This is a decimal string and is not rounded to the integer value.

4.4.5.6 XA Positioner Module

TABLE 4-13
XA POSITIONER MODULE ATTRIBUTES

Attribute Name	Tag	Type	Attribute Description
Distance Source to Detector	(0018,1110)	3	This value is 1000 mm nominal.
Positioner Motion	(0018,1500)	2C	This value is always set to "STATIC" since the system does not know if the Positioner is in motion. The system may have been in motion during the irradiation event.
Positioner Primary Angle	(0018,1510)	2	Value will be "".
Positioner Secondary Angle	(0018,1511)	2	Value will be "".
Positioner Motion	(0018,1500)	2C	Value will only be present for MD system. Value will be DYNAMIC or STATIC.
Positioner Primary Angle	(0018,1510)	2	Value will only be present for MD system.
Positioner Secondary Angle	(0018,1511)	2	Value will only be present for MD system.
Positioner Primary Angle Increment	(0018,1520)	2C	Value will only be present for MD system.
Positioner Secondary Angle Increment	(0018,1521)	2C	Value will only be present for MD system.

4.4.5.7 DX Detector Module

TABLE 4-14
DX DETECTOR MODULE ATTRIBUTES

Attribute Name	Tag	Type	Attribute Description
Detector Type	(0018,7004)	2	The value is set to SCINTILLATOR.
Imager Pixel Spacing	(0018,1164)	1	Current detectors have Imager Pixel values of: 21 cm FPD 0.135 mm – All magnifications 31 cm FPD 0.198 mm – All magnifications 9 inch II <ul style="list-style-type: none"> • Norm – 0.3 mm

Attribute Name	Tag	Type	Attribute Description
			<ul style="list-style-type: none"> • Mag1 – 0.23 mm • Mag2 – 0.15 mm 12 inch II <ul style="list-style-type: none"> • Norm – 0.23 mm • Mag1 – 0.15 mm • Mag2 – 0.11 mm Magnification refers to the Field of View (FOV). For the II systems, physical distance at the front plane of the Image Receptor housing does change when the FOV is changed. The value of this attribute shall never be adjusted to account for correction for the effect of geometric magnification or calibration against an object of known size; Pixel Spacing (0028,0030) is specified for that purpose.
Pixel Spacing	(0028,0030)	1C	When the user has calibrated the measurement in the image, the system will provide the pixel spacing based on the calibration values given by the user.

4.4.5.8 Overlay Plane Module

The product supports up to 2 overlays in an image. The two overlays can be merged based on configuration by the user. The demographic information can also be controlled by the user using the Applications > Setup > Patient Information screen.

**TABLE 4-15
OVERLAY PLANE MODULE ATTRIBUTES**

Attribute Name	Tag	Type	Attribute Description
Overlay Rows	(60xx,0010)	1	The value will be set to 1280 for full size and 640 for half size image.
Overlay Columns	(60xx,0011)	1	The value will be set to 1280 for full size and 640 for half size image.
Overlay Type	(60xx,0040)	1	The value will be set to 'G' which equals Graphics.
Overlay Origin	(60xx,0050)	1	The value will be set to '1\1'.
Overlay Bits Allocated	(60xx,0100)	1	The value will be set to 1.
Overlay Bit Position	(60xx,0102)	1	The value will be set to 0.
Overlay Data	(60xx,3000)	1	The graphic data with monochrome values.
Overlay Label	(60xx,1500)	3	See the section 4.4.5.8.1.

4.4.5.8.1 Overlay Label

The names of the overlays change based on what is sent and the settings for the operation to the Media or PACS.

The overlay labels are:

- Demographic Information Overlay - when no annotations are present.
- Image Information Overlay - when the data is de-identified (Media Image Save only).
- Demographic-Image Information Overlay - when the overlays are merged
- Image Annotation Overlay - when the image is annotated and this is the second overlay
- Image Info-Image Annotation Overlay - when the overlays are merged and de-identified (only supported for Media Image Save).

4.4.5.9 VOI LUT module

TABLE 4-16
VOI LUT MODULE ATTRIBUTES

Attribute Name	Tag	Type	Attribute Description
Window Center	(0028,1050)	1C	Set the value from the image histogram or default to be 511 for 10 bit images and 127 for 8 bit images.
Window Width	(0028,1051)	1C	Set the value from the image histogram or default to be 1023 for 10 bit images and 255 for 8 bit images.

4.4.5.10 SOP Common Module

TABLE 4-17
SOP COMMON MODULE ATTRIBUTES

Attribute Name	Tag	Type	Attribute Description
SOP Class UID	(0008,0016)	1	Set the value defined by the modality used to store the object.
SOP Instance UID	(0008,0018)	1	Set to a system defined unique value.
Specific Character Set	(0008,0005)	1C	Defined to be ISO_IR 100 which equals the Latin Alphabet No. 1
Instance Creation Date	(0008,0012)	3	Set the value to the Date the SOP Instance was created. For Image IOD this is the date the image is copied to the PACS or Media. For RDSR this is the date the report was created.
Instance Creation Time	(0008,0013)	3	Set the value to the Date the SOP Instance was created. For Image IOD this is the date the image is copied to the PACS or Media. For RDSR this is the date the report was created.
Instance Creator UID	(0008,0014)	3	Set to a system defined unique value for the system.
Instance Number	(0020,0013)	3	Set to the number displayed on the Images screen for an image.

4.4.5.11 Cine Module

TABLE 4-18
CINE MODULE ATTRIBUTES

Attribute Name	Tag	Type	Attribute Description
Preferred Playback Sequencing	(0018,1244)	3	Set the value of 0 for Looping.
Frame Time	(0018,1063)	1C	Set to millisecond value with two decimal places.
Recommended Display Frame Rate	(0018,0040)	3	Set the acquire rate from the system.
Cine Rate	(0018,0040)	3	Set the acquire rate from the system.
Effective Duration	(0018,0072)	3	Total Frames in multi-frame image divided by acquire rate.
Actual Frame Duration	(0018,1242)	3	Set to the system pulse width for the image acquisition.

4.4.5.12 Mask Module

TABLE 4-19
MASK MODULE ATTRIBUTES

Attribute Name	Tag	Type	Attribute Description
Mask Subtraction Sequence	(0028,6100)	1	This is the sequence tag
>Mask Operation	(0028,6101)	1	Set to the value NONE.
Recommended Viewing Mode	(0028,1090)	2	Value set to NAT.

4.4.5.13 Multi-Frame Module

TABLE 4-20
MULTI-FRAME MODULE ATTRIBUTES

Attribute Name	Tag	Type	Attribute Description
Number of Frames	(0028,0008)	1	Number of frames in the multi-frame image.
Frame Increment Pointer	(0028,0009)	1	Value set to (0018,1063).

4.4.5.14 Frame Pointers Module

TABLE 4-21
FRAME POINTERS MODULE ATTRIBUTES

Attribute Name	Tag	Type	Attribute Description
Representative Frame Number	(0028,6010)	3	Frame used as the thumbnail on system.

4.5 STANDARD EXTENDED AND PRIVATE DATA ATTRIBUTES

The Product supports the Standard Attributes defined in the following sections in Standard Extended X-Ray Angiographic SOP Instances as Type 3 data elements.

No Private attributes are supported in the X-Ray Angiographic SOP Instance.

4.5.1 Standard Attributes

The Product supports the following attributes, not specified in the X-Ray Angiographic IOD, in SOP Instances as Type 3 data elements.

**TABLE 4-22
STANDARD EXTENDED ATTRIBUTES**

Information Entity Name	Attribute Name	Tag	Use
Patient	N/A	N/A	N/A
Study	N/A	N/A	N/A
	N/A	N/A	N/A
Series	N/A	N/A	N/A
	N/A	N/A	N/A
Image	Comments on Radiation Dose	(0040,0310)	Set value to text of "Low Dose On/Off", which results from user selection of "Low Dose" mode on or off.

4.6 STANDARD EXTENDED AND PRIVATE CONTEXT GROUPS

The Product supports standard coded terminology but no extension is made for the XA SOP instance. No Private Context Groups are supported.

5. X-RAY RF INFORMATION OBJECT IMPLEMENTATION

5.1 INTRODUCTION

This section specifies the use of the DICOM X-Ray RF Image IOD to represent the information included in XRF Images produced or received by this implementation. Corresponding attributes are conveyed using the module construct.

5.2 OEC ELITE MAPPING OF DICOM ENTITIES

The OEC Elite maps DICOM Information Entities to local Information Entities in the product’s database and user interface.

TABLE 5-1
MAPPING OF DICOM ENTITIES TO OEC ELITE ENTITIES

DICOM IE	OEC Elite Entity
Patient	Patient
Study	Exam
Series	Series
Image	Image

5.3 IOD MODULE TABLE

The XRF Image Information Object Definition comprises the modules of the following table, plus Standard Extended attributes. Standard Extended attributes are described in Section 5.5.

TABLE 5-2
XRF IMAGE IOD MODULES

Entity Name	Module Name	Usage	Reference
Patient	Patient	Used	4.4.1.1
	Clinical Trial Subject	Not Used	N/A
Study	General Study	Used	4.4.2.1
	Patient Study	Used when the data is passed by the Modality Worklist.	4.4.2.2
	Clinical Trial Study	Not Used	N/A
Series	General Series	Used	4.4.3.1
	Clinical Trial Series	Not Used	N/A
Frame of Reference	Synchronization	Not Used	N/A
Equipment	General Equipment	Used	4.4.4.1
Image	General Image	Used	4.4.5.1
	General Reference	Not Used	N/A
	Image Pixel	Used	4.4.5.2
	Contrast/Bolus	Present	4.4.5.3

Entity Name	Module Name	Usage	Reference
		Required if contrast media was used in this image, the system does not presently know if contrast was used or not.	
	Cine	Used when image is multi-frame.	4.4.5.11
	Multi-frame	Used when image is multi-frame.	4.4.5.13
	Frame Pointers	Used when image is multi-frame.	4.4.5.14
	Mask	Used when image is Subtract mode image	4.4.5.12
	X-Ray Image	Used	4.4.5.4
	X-Ray Acquisition	Used	4.4.5.5
	X-Ray Collimator	Not Used	N/A
	Display Shutter	Not Used	N/A
	Device	Not Used	N/A
	Intervention	Not Used	N/A
	Specimen	Not Used	N/A
	X-Ray Table	Not Used	N/A
	XRF Positioner	Used	5.4.1.1
	X-Ray Tomo Acquisition	Not Used	N/A
	DX Detector	Used	4.4.5.7
	Overlay Plane	Used when the user specifies the overlay to be stored for a DICOM Store and used in Media.	4.4.5.8
	Multi-Frame Overlay	Not Used	N/A
	Modality LUT	Not Used	N/A
	VOI LUT	Used to provide the Window Width and Center for the image.	4.4.5.9
	SOP Common	Used	4.4.5.10
	Common Instance Reference	Not Used	N/A
	Frame Extraction	Not Used	N/A

5.4 INFORMATION MODULE DEFINITIONS

Please refer to DICOM Part 3 (Information Object Definitions) for a description of each of the entities, modules, and attributes contained within the X-Ray RF Information Object.

The following modules are included to convey Enumerated Values, Defined Terms, and Optional Attributes supported or expected. Type 1 & Type 2 Attributes are also included for completeness and to define what values they may take and where these values are obtained from when generating the instance as well as what are the expected values when loading such instance. It

should be noted that they are the same ones as defined in the DICOM Standard Part 3 (Information Object Definitions). Also note that Attributes not present in tables are not supported.

5.4.1.1 XRF Positioner Module

**TABLE 5-3
 XRF POSITIONER MODULE ATTRIBUTES**

Attribute Name	Tag	Type	Attribute Description
Distance Source to Detector	(0018,1110)	3	This value is 1000 mm nominal.

5.5 STANDARD EXTENDED AND PRIVATE DATA ATTRIBUTES

The Product supports the Standard Attributes defined in the following sections in Standard Extended X-Ray RF SOP Instances as Type 3 data elements.

5.5.1 Standard Attributes

The Product supports the following attributes, not specified in the X-Ray RF IOD, in SOP Instances as Type 3 data elements.

**TABLE 5-4
 STANDARD EXTENDED ATTRIBUTES**

Information Entity Name	Attribute Name	Tag	Use
Patient	N/A	N/A	N/A
Study	N/A	N/A	N/A
	N/A	N/A	N/A
Series	N/A	N/A	N/A
	N/A	N/A	N/A
Image	Comments on Radiation Dose	(0040,0310)	Set value to text of “Low Dose On/Off”, which results from user selection of “Low Dose” mode on or off.
Patient	N/A	N/A	N/A

5.6 STANDARD EXTENDED AND PRIVATE CONTEXT GROUPS

The Product supports standard coded terminology but no extension is made for the XA SOP instance. No Private Context Groups are supported.

6. CR INFORMATION OBJECT IMPLEMENTATION

6.1 INTRODUCTION

This section specifies the use of the DICOM CR Image IOD to represent the information included in CR Images produced or received by this implementation. Corresponding attributes are conveyed using the module construct.

6.2 OEC ELITE MAPPING OF DICOM ENTITIES

The OEC Elite maps DICOM Information Entities to local Information Entities in the product’s database and user interface.

TABLE 6-1
MAPPING OF DICOM ENTITIES TO OEC ELITE ENTITIES

DICOM IE	OEC Elite Entity
Patient	Patient
Study	Exam
Series	Series
Image	Image

6.3 IOD MODULE TABLE

The Computed Radiography Information Object Definition comprises the modules of the following table, plus Standard Extended and Private attributes. Standard Extended and Private attributes are described in Section 6.5.

TABLE 6-2
CR IMAGE IOD MODULES

Entity Name	Module Name	Usage	Reference
Patient	Patient	Used	4.4.1.1
	Clinical Trial Subject	Not Used	N/A
Study	General Study	Used	4.4.2.1
	Patient Study	Used when the data is passed by the Modality Worklist.	4.4.2.2
	Clinical Trial Study	Not Used	N/A
Series	General Series	Used	4.4.3.1
	CR Series	Used	6.4.1.1
	Clinical Trial Series	Not Used	N/A
Equipment	General Equipment	Used	4.4.4.1
Image	General Image	Used	4.4.5.1
	General Reference	Not Used	N/A
	Image Pixel	Used	4.4.5.2
	Contrast/Bolus	Present	4.4.5.3

Entity Name	Module Name	Usage	Reference
		Required if contrast media was used in this image, the system does not presently know if contrast was used or not.	
	Display Shutter	Not Used	N/A
	Device	Not Used	N/A
	Specimen	Not Used	N/A
	CR Image	Used	6.4.2.1
	Overlay Plane	Used when the user specifies the overlay to be stored for a DICOM Store and used in Media.	4.4.5.8
	Modality LUT	Not Used	N/A
	VOI LUT	Used to provide the Window Width and Center for the image.	4.4.5.9
	SOP Common	Used	4.4.5.10
	Common Instance Reference	Not Used	N/A

6.4 INFORMATION MODULE DEFINITIONS

Please refer to DICOM Part 3 (Information Object Definitions) for a description of each of the entities, modules, and attributes contained within the CR Information Object.

The following modules are included to convey Enumerated Values, Defined Terms, and Optional Attributes supported or expected. Type 1 & Type 2 Attributes are also included for completeness and to define what values they may take and where these values are obtained from when generating the instance as well as what are the expected values when loading such instance. It should be noted that they are the same ones as defined in the DICOM Standard Part 3 (Information Object Definitions). Also note that Attributes not present in tables are not supported.

6.4.1 Series Entity Modules

6.4.1.1 CR Series Module

**TABLE 6-3
 CR SERIES MODULE ATTRIBUTES**

Attribute Name	Tag	Type	Use
Body Part Examined	(0018,0015)	2	The value will always be blank.
View Position	(0018,5101)	2	The value will always be blank.

6.4.2 Image Entity Modules

6.4.2.1 CR Image Module

**TABLE 6-4
CR IMAGE MODULE ATTRIBUTES**

Attribute Name	Tag	Type	Use
Photometric Interpretation	(0028,0004)	1	The value will be set to MONOCHROME2.
KV	(0018,0060)	3	Set to the average value of the x-ray exposure.
Distance Source to Detector	(0018,1110)	3	This value is 1000 mm nominal.
Exposure Time	(0018,1150)	3	The time is reported as the ceiling of the milliseconds for this irradiation event. For pulsed mode irradiation events, only the pulsed irradiations are counted. There is a single continuous mode scout irradiation which is not counted with this value.
X-ray Tube Current	(0018,1151)	3	The average value for the irradiation event is reported. The value is the ceiling of the decimal number of the current since this tag is an integer.
Exposure	(0018,1152)	3	The exposure is reported as the ceiling of the mAs for this irradiation event. For pulsed mode irradiation events, only the pulsed irradiations are counted. There is a single continuous mode scout irradiation which is not counted with this value.
Exposure in μ As	(0018,1153)	3	The exposure is reported as microAs for this irradiation event. For pulsed mode irradiation events, only the pulsed irradiations are counted. There is a single continuous mode scout irradiation which is not counted with this value.
Imager Pixel Spacing	(0018,1164)	3	<p>Current detectors have Imager Pixel values of:</p> <p>21 cm FPD 0.135 mm – All magnifications 31 cm FPD 0.198 mm – All magnifications</p> <p>9 inch II</p> <ul style="list-style-type: none"> • Norm – 0.3 mm • Mag1 – 0.23 mm • Mag2 – 0.15 mm <p>12 inch II</p> <ul style="list-style-type: none"> • Norm – 0.23 mm • Mag1 – 0.15 mm • Mag2 – 0.11 mm <p>Magnification refers to the Field of View (FOV). For the II systems, physical distance at the front plane of the Image Receptor housing does change when the FOV is changed.</p>

Attribute Name	Tag	Type	Use
			The value of this attribute shall never be adjusted to account for correction for the effect of geometric magnification or calibration against an object of known size; Pixel Spacing (0028,0030) is specified for that purpose.
Pixel Spacing	(0028,0030)	1C	When the user has calibrated the measurement in the image, the system will provide the pixel spacing based on the calibration values given by the user.
Anatomic Region Sequence	(0008,2218)	3	Value is set by the user, the default is an extended value of 'Topography Unknown'.
> <i>Include 'Code Sequence Macro'</i>			Values supported are list in section 6.5.1.1

6.5 STANDARD EXTENDED AND PRIVATE DATA ATTRIBUTES

The Product supports the Standard Attributes defined in the following sections in Standard Extended CR SOP Instances as Type 3 data elements.

6.5.1 Standard Attributes

The Product supports the following attributes, not specified in the CR IOD, in SOP Instances as Type 3 data elements.

**TABLE 6-5
 STANDARD EXTENDED ATTRIBUTES**

Information Entity Name	Attribute Name	Tag	Use
Patient	N/A	N/A	N/A
Study	N/A	N/A	N/A
	N/A	N/A	N/A
Series	N/A	N/A	N/A
	N/A	N/A	N/A
Image	Comments on Radiation Dose	(0040,0310)	Set value to text of “Low Dose On/Off”, which results from user selection of “Low Dose” mode on or off.
	N/A	N/A	N/A

6.5.1.1 Context ID 4031/4009 Common Anatomic Regions

The following list of values are used in tag (0008,2218) Anatomic Region Sequence for CR SOP Instances, the value can be set by the user.

**TABLE 6-6
TABLE CID 403**

Code Meaning	Code Value	Coding Scheme Designator
Topography Unknown	T-D0001	SRT ⁽¹⁾
Abdomen	T-D4000	SRT
Ankle joint	T-15750	SRT
Bile duct	T-60610	SRT
Bladder	T-74000	SRT
Calcaneus	T-12770	SRT
Cervical spine	T-11501	SRT
Chest	T-D3000	SRT
Clavicle	T-12310	SRT
Coccyx	T-11BF0	SRT
Elbow	T-D8300	SRT
Esophagus	T-56000	SRT
Facial bones	T-11196	SRT
Femur	T-12710	SRT
Finger	T-D8800	SRT
Foot	T-D9700	SRT
Forearm bone	T-12402	SRT
Gall bladder	T-63000	SRT
Hand	T-D8700	SRT
Heart	T-32000	SRT
Hip joint	T-15710	SRT
Humerus	T-12410	SRT
Knee	T-D9200	SRT
Leg	T-D9400	SRT
Lumbar spine	T-11503	SRT
Mandible	T-11180	SRT
Maxilla	T-11170	SRT
Nasal bone	T-11149	SRT
Orbital structure	T-D14AE	SRT
Pancreatic duct and bile duct systems	T-65600	SRT
Paranasal sinus	T-22000	SRT
Patella	T-12730	SRT
Pelvis	T-D6000	SRT
Rib	T-11300	SRT
Sacroiliac joint	T-15680	SRT
Sacrum	T-11AD0	SRT
Scapula	T-12280	SRT
Shoulder	T-D2220	SRT
Skull	T-11100	SRT
Sternum	T-11210	SRT
Stomach	T-57000	SRT

Code Meaning	Code Value	Coding Scheme Designator
Temporomandibular joint	T-15290	SRT
Thoracic spine	T-11502	SRT
Thumb	T-D8810	SRT
Toe	T-D9800	SRT
Upper urinary tract	T-70010	SRT
Ureter	T-73000	SRT
Urethra	T-75000	SRT
Uterus and fallopian tubes	T-88920	SRT
Wrist joint	T-15460	SRT

1 – This value is an extension of the CID 4031 extensible list

6.6 STANDARD EXTENDED AND PRIVATE CONTEXT GROUPS

The Product supports standard coded terminology but no extension is made for the CR SOP instance. No Private Context Groups are supported.

7. SECONDARY CAPTURE INFORMATION OBJECT IMPLEMENTATION

7.1 INTRODUCTION

This section specifies the use of the DICOM SC Image IOD to represent the information included in SC Images produced or received by this implementation. Corresponding attributes are conveyed using the module construct.

7.2 OEC ELITE MAPPING OF DICOM ENTITIES

The OEC Elite maps DICOM Information Entities to local Information Entities in the product's database and user interface.

TABLE 7-1
MAPPING OF DICOM ENTITIES TO OEC ELITE ENTITIES

DICOM IE	OEC Elite Entity
Patient	Patient
Study	Exam
Series	Series
Image	Image

7.3 IOD MODULE TABLE

The Secondary Capture Information Object Definition comprises the modules of the following table, plus Standard Extended and Private attributes. Standard Extended and Private attributes are described in Section 8.4.1.

**TABLE 7-2
SC IMAGE IOD MODULES**

Entity Name	Module Name	Usage	Reference
Patient	Patient	Used	4.4.1.1
	Clinical Trial Subject	Not Used	N/A
Study	General Study	Used	4.4.2.1
	Patient Study	Used when the data is passed by the Modality Worklist.	4.4.2.2
	Clinical Trial Study	Not Used	N/A
Series	General Series	Used	4.4.3.1
	Clinical Trial Series	Not Used	N/A
Equipment	General Equipment	Used	4.4.4.1
	SC Equipment	Used	Error! Reference source not found.
Image	General Image	Used	4.4.5.1
	General Reference	Not Used	N/A
	Image Pixel	Used	4.4.5.2
	Device	Not Used	N/A
	Specimen	Not Used	N/A
	SC Image	Used	Error! Reference source not found.
	Overlay Plane	Used when the user specifies the overlay to be stored for a DICOM Store and always used in Media.	4.4.5.8
	Modality LUT	Not Used	N/A
	VOI LUT	Used to provide the Window Width and Center for the image.	4.4.5.9
	ICC Profile	Not Used	N/A
	SOP Common	Used	4.4.5.10
	Common Instance Reference	Not Used	N/A

7.4 INFORMATION MODULE DEFINITIONS

Please refer to DICOM Standard Part 3 (Information Object Definitions) for a description of each of the entities and modules contained within the SC Information Object.

The following modules are included to convey Enumerated Values, Defined Terms, and Optional Attributes supported or expected. Type 1 & Type 2 Attributes are also included for completeness and to define what values they may take and where these values are obtained from when generating the instance as well as what are the expected values when loading such instance. It should be noted that they are the same ones as defined in the

DICOM Standard Part 3 (Information Object Definitions). Also note that Attributes not present in tables are not supported.

7.4.1 Equipment Entity Modules

7.4.1.1 SC Equipment Module

**TABLE 7-3
 SC EQUIPMENT MODULE ATTRIBUTES**

Attribute Name	Tag	Type	Use
Conversion Type	(0008,0064)	1	The value will be set to WSD.
Modality	(0008,0060)	3	The value will be set to OT.
Secondary Capture Device ID	(0018,1010)	3	The value is set to the system serial number.
Secondary Capture Device Manufacturer	(0018,1016)	3	The value is set to the "GE Healthcare ".
Secondary Capture Device Manufacturer's Model Name	(0018,1018)	3	The value is set to the model of the system.
Secondary Capture Device Software Version	(0018,1019)	3	The value is set to the software version of the system.

7.4.2 Image Entity Modules

7.4.2.1 SC Image Module

**TABLE 7-4
 SC IMAGE MODULE ATTRIBUTES**

Attribute Name	Tag	Type	Use
Date of Secondary Capture	(0018,1012)	3	The value is set to the date the image is created on the system.
Time of Secondary Capture	(0018,1014)	3	The value is set to the time the image is created on the system.

7.5 STANDARD EXTENDED AND PRIVATE DATA ATTRIBUTES

The Product does not support any additional standard extended attributes in Standard Extended SC SOP Instances as Type 3 data elements.

7.6 STANDARD EXTENDED AND PRIVATE CONTEXT GROUPS

The Product does not support coded terminology using any Standard Extended, Private, or Configurable Context Groups defined in the following sections.

8. MULTI-FRAME GRAYSCALE BYTE SC INFORMATION OBJECT IMPLEMENTATION

8.1 INTRODUCTION

This section specifies the use of the DICOM Multi-frame Grayscale Byte SC Image IOD to represent the information included in Multi-frame SC Images produced or received by this implementation. Corresponding attributes are conveyed using the module construct.

8.2 OEC ELITE MAPPING OF DICOM ENTITIES

The OEC Elite maps DICOM Information Entities to local Information Entities in the product’s database and user interface.

TABLE 8-1
MAPPING OF DICOM ENTITIES TO OEC ELITE ENTITIES

DICOM IE	OEC Elite Entity
Patient	Patient
Study	Exam
Series	Series
Image	Image

8.3 IOD MODULE TABLE

The Multi-frame Grayscale Byte SC Image Information Object Definition comprises the modules of the following table, plus Standard Extended and Private attributes. Standard Extended and Private attributes are described in Section 8.4.1.

TABLE 8-2
MULTI-FRAME GRAYSCALE BYTE SC IMAGE IOD MODULES

Entity Name	Module Name	Usage	Reference
Patient	Patient	Used	4.4.1.1
	Clinical Trial Subject	Not Used	N/A
Study	General Study	Used	4.4.2.1
	Patient Study	Used when the data is passed by the Modality Worklist.	4.4.2.2
	Clinical Trial Study	Not Used	N/A
Series	General Series	Used	4.4.3.1
	Clinical Trial Series	Not Used	N/A
Equipment	General Equipment	Used	4.4.4.1
	SC Equipment	Used	Error! Reference source not found.
Frame of Reference	Frame of Reference	Not Used	N/A
	Synchronization	Not Used	N/A
Image	General Image	Used	4.4.5.1
	General Reference	Not Used	N/A
	Image Pixel	Used	4.4.5.2
	Cine	Used	4.4.5.11
	Multi-frame	Used	4.4.5.13
	Frame Pointers	Used	4.4.5.14
	Device	Not Used	N/A
	Multi-frame Functional Groups	Not Used	N/A
	Multi-frame Dimension	Not Used	N/A
	Specimen	Not Used	N/A
	SC Image	Used	Error! Reference source not found.
	SC Multi-frame Image	Used	8.4.1
	SC Multi-frame Vector	Not applicable. No required conditions are met.	N/A
	VOI LUT	Used to provide the Window Width and Center for the image.	4.4.5.9
	SOP Common	Used	4.4.5.10
	Common Instance Reference	Not Used	N/A
Frame Extraction	Not applicable. Condition not met.	N/A	

8.4 INFORMATION MODULE DEFINITIONS

Please refer to DICOM Standard Part 3 (Information Object Definitions) for a description of each of the entities and modules contained within the Multi-frame Grayscale Byte SC Information Object.

The following modules are included to convey Enumerated Values, Defined Terms, and Optional Attributes supported or expected. Type 1 & Type 2 Attributes are also included for completeness and to define what values they may take and where these values are obtained from when generating the instance as well as what are the expected values when loading such instance. It should be noted that they are the same ones as defined in the DICOM Standard Part 3 (Information Object Definitions). Also note that Attributes not present in tables are not supported.

8.4.1 SC Multi-frame Image Module

**TABLE 8-3
 SC MULTI-FRAME IMAGE MODULE ATTRIBUTES**

Attribute Name	Tag	Type	Attribute Description
Burned in Annotation	(0028,0301)	1	Value set to NO.
Presentation LUT Shape	(2050,0020)	1C	Value set to IDENTITY.
Rescale Intercept	(0028,1052)	1C	Value set to 0.
Rescale Slope	(0028,1053)	1C	Value set to 1.
Rescale Type	(0028,1054)	1C	Value set to US (Unspecified)

8.5 STANDARD EXTENDED AND PRIVATE DATA ATTRIBUTES

The Product does not support any additional standard extended attributes in Standard Extended Multi-frame Grayscale Byte SC SOP Instances as Type 3 data elements.

8.6 STANDARD EXTENDED AND PRIVATE CONTEXT GROUPS

The Product does not support coded terminology using any Standard Extended, Private, or Configurable Context Groups defined in the following sections.

9. X-RAY RADIATION DOSE STRUCTURED REPORT INFORMATION OBJECT IMPLEMENTATION

9.1 INTRODUCTION

This section specifies the use of the DICOM X-Ray Radiation Dose SR IOD to represent results produced by this implementation. Corresponding attributes are conveyed using the module construct.

9.2 OEC ELITE MAPPING OF DICOM ENTITIES

The OEC Elite maps DICOM Information Entities to local Information Entities in the product’s database and user interface.

TABLE 9-1
MAPPING OF DICOM ENTITIES TO OEC ELITE ENTITIES

DICOM IE	OEC Elite Entity
Patient	Patient
Study	Exam
Series	Series
Document	Document

9.3 IOD MODULE TABLE

The X-Ray Radiation Dose Structured Report Information Object Definitions comprise the modules of the following tables, plus Standard Extended and Private attributes. Standard Extended and Private attributes are described in Section 9.5

The contents of the SR Document Content are constrained by the supported template, as identified in Section 9.4.2.2.1.1. Standard, Standard Extended and Private templates are further described in Section 9.7.

TABLE 9-2
STRUCTURE REPORT IOD MODULES

Entity Name	Module Name	Usage	Reference
Patient	Patient	Used	4.4.1.1
	Specimen Identification	Not Used	N/A
	Clinical Trial Subject	Not Used	N/A
Study	General Study	Used	4.4.2.1
	Patient Study	Used when the data is passed by the Modality Worklist.	4.4.2.2
	Clinical Trial Study	Not Used	N/A
Series	SR Document Series	Used	9.4.1.1
	Clinical Trial Series	Not Used	N/A
Frame Of Reference	Synchronization	Not Used	N/A

Equipment	General Equipment	Used	4.4.4.1
Document	SR Document General	Used	9.4.2.1
	SR Document Content	Used	9.4.2.2
	SOP Common	Used	4.4.5.10

9.4 INFORMATION MODULE DEFINITIONS

Please refer to DICOM Part 3 (Information Object Definitions) for a description of each of the entities, modules, and attributes contained within the SR Information Objects.

The following modules are included to convey Enumerated Values, Defined Terms, and Optional Attributes supported. Type 1 & Type 2 Attributes are also included for completeness and to define what values they may take and where these values are obtained from when generating the instance. It should be noted that they are the same ones as defined in the DICOM Standard Part 3 (Information Object Definitions). Also note that Attributes not present in tables are not supported.

9.4.1 Series Entity Modules

9.4.1.1 SR Document Series Module

**TABLE 9-3
SR DOCUMENT SERIES MODULE ATTRIBUTES**

Attribute Name	Tag	Type	Use
Modality	(0008,0060)	1	Value = SR
Series Instance UID	(0020,000E)	1	Value generated by the system.
Series Number	(0020,0011)	1	Value generated by the system.
Series Date	(0008,0021)	3	Value of the Series date is the procedure step start date. Each procedure step defines a new series.
Series Time	(0008,0031)	3	Value of the Series time is the procedure step start time. Each procedure step defines a new series.
Series Description	(0008,103E)	3	Value of the Protocol Description on the Additional Information screen.
Referenced Performed Procedure Step Sequence	(0008,1111)	2	Value generated by the system. Currently does not correspond to an actual PPS generated by the system.
> <i>'Referenced SOP Class / Instance UIDs'</i>			

9.4.2 Document Entity Modules

9.4.2.1 SR Document General Module

**TABLE 9-4
SR DOCUMENT GENERAL MODULE ATTRIBUTES**

Attribute Name	Tag	Type	Use
Instance Number	(0020,0013)	1	Value assigned by the system.
Completion Flag	(0040,A491)	1	Value equals COMPLETE = Complete content.
Verification Flag	(0040,A493)	1	Value equals UNVERIFIED = Not attested to.
Content Date	(0008,0023)	1	Value equal to the date the exam is completed/abandoned.
Content Time	(0008,0033)	1	Value equal to the time the exam is completed/abandoned.
Verifying Observer Sequence	(0040,A073)	1C	Not present. Currently not supported on the AE
Author Observer Sequence	(0040,A078)	3	Value is set to Device macro values.
<i>>Include 'Identified Person or Device Macro'</i>			
Custodial Organization Sequence	(0040,A07C)	3	
>Institution Name	(0008,0080)	2	Value set to Hospital Name entered on Setup > Regional Settings screen.
>Institution Code Sequence	(0008,0082)	2	Empty sequence
<i>>>Include 'Code Sequence Macro'</i>			
Predecessor Documents Sequence	(0040,A360)	1C	Not present.
Identical Documents Sequence	(0040,A525)	1C	Not present.
Referenced Request Sequence	(0040,A370)	1C	Populated with values from the system.
>Study Instance UID	(0020,000D)	1	Populated with the Study Instance UID.
>Referenced Study Sequence	(0008,1110)	2	Contains the Referenced Study Sequence received in the MWL
<i>>>Include 'SOP Instance Reference Macro'</i>			
>Accession Number	(0008,0050)	2	Populated with the value from the MWL or entered by the user.
>Placer Order Number/Imaging Service Request	(0040,2016)	2	Populated with the value from the MWL or blank.
>Filler Order Number/Imaging Service Request	(0040,2017)	2	Populated with the value from the MWL or blank.
>Requested Procedure ID	(0040,1001)	2	Populated with the value from the MWL or blank.
>Requested Procedure Description	(0032,1060)	2	Populated with the value from the MWL or blank.
>Requested Procedure Code Sequence	(0032,1064)	2	Populated with the value from the MWL or empty.
<i>>>Include 'Code Sequence Macro'</i>			
>Reason for the Requested Procedure	(0040,1002)	3	Populated with the value from the MWL
>Reason for Requested Procedure Code Sequence	(0040,100A)	3	Populated with the value from the MWL
<i>>>Include 'Code Sequence Macro'</i>			
Performed Procedure Code Sequence	(0040,A372)	2	Populated with the value from the MWL
<i>>Include Code Sequence Macro</i>			

Attribute Name	Tag	Type	Use
Current Requested Procedure Evidence Sequence	(0040,A375)	1C	Populated with the SOP instances of all images stored to PACS.
<i>>Include 'Hierarchical SOP Instance Reference Macro'</i>			
Pertinent Other Evidence Sequence	(0040,A385)	1C	Not present per conditional
<i>> Include 'Hierarchical SOP Instance Reference Macro'</i>			
Referenced Instance Sequence	(0008,114A)	1C	Not present per conditional
<i>>Include 'SOP Instance Reference Macro'</i>			

9.4.2.2 SR Document Content Module

TABLE 9-5
SR DOCUMENT CONTENT MODULE ATTRIBUTES

Attribute Name	Tag	Type	Use
Observation DateTime	(0040,A032)	1C	Not present per conditional
Content Template Sequence	(0040,A504)	1C	
>Mapping Resource	(0008,0105)	1	Value set to DCMR.
>Template Identifier	(0040,DB00)	1	Value set to 10001
Value Type	(0040,A040)	1	
Continuity of Content	(0040,A050)	1C	Set to 'SEPARATE'.
Concept Name Code Sequence	(0040,A043)	1C	
>Code Value	(0008,0100)	1	Value set to 113701.
>Code Value	(0008,0102)	1	Value set to DCM.
>Code Meaning	(0008,0104)	1	Value set to "X-Ray Radiation Dose Report"
Content Sequence	(0040,A730)	1C	
> Relationship Type	(0040,A010)	1	Value set to 'HAS CONCEPT MOD'
> Referenced Content Item Identifier	(0040,DB73)	1C	Not present since not a reference.
<i>> Insert SR DocumentContent Module</i>			Recursive inclusion to create document content tree. See section 9.4.2.2.1.1 for the list of supported templates

9.4.2.2.1 SR Document Content Descriptions

9.4.2.2.1.1 Content Template

The product supports the following root Template for SR SOP Instances created by the product.

**TABLE 9-6
 SR ROOT TEMPLATES**

SOP Class	Template ID	Template Name	Use
X-Ray Radiation Dose SR	10001	X-Ray Radiation Dose	Create

Refer to section 9.7 for a detailed description of the supported templates.

9.5 STANDARD EXTENDED AND PRIVATE DATA ATTRIBUTES

The Product does not support the Standard Extended Attributes for Standard Extended SR SOP Instances as Type 3 data elements.

9.6 STANDARD EXTENDED AND PRIVATE CONTEXT GROUPS

The Product supports coded terminology using Standard Extended Context Groups defined in the following sections.

9.6.1 Standard Extended Context Groups

The Product supports the following extensions to standard Context Groups for SR SOP Instances created by this product. Extensions are indicated by **bold text**.

9.6.1.1 Context ID 4031/4009 Common Anatomic Regions

See section 6.5.1.1 for the details of the list.

9.6.1.2 Context ID 3629 Procedure Intent

**TABLE 9-7
TABLE CID 3629**

Code Meaning	Code Value	Coding Scheme Designator
Diagnostic Intent	R-408C3	SRT
Therapeutic Intent	R-41531	SRT
Combined Diagnostic and Therapeutic Procedure	R-002E9	SRT
Staging intent	R-408F2	SRT
Guidance Intent	R-40641	SRT
Forensic Intent	R-40644	SRT
Screening Intent	R-42453	SRT
Palliative Intent	R-40644	SRT
Adjunct intent	R-41564	SRT
Adjuvant intent	R-41561	SRT
Curative intent	R-41560	SRT
Neo-adjuvant intent	R-41562	SRT
Supportive intent	R-41563	SRT
Preventive intent	P0-02179	SRT
Prophylactic intent	P0-02180 ¹	SRT
Quality Control Intent	G-C0E8	SRT

Note 1 – Value in DICOM PS3.16 2014c is P0-02180.

9.7 STANDARD, STANDARD EXTENDED AND PRIVATE TEMPLATES

The Product supports the Standard Extended Templates defined in the following sections.

9.7.1 Standard Templates

The Product supports the following standard templates for SOP Instances created by this product.

9.7.1.1 Template ID 10001 X-Ray Radiation Dose

NL	Rel with Parent	VT	Concept Name	VM	Req Type	Condition	Value Set Constraint
		CONTAINER	EV (113701, DCM, "X-Ray Radiation Dose Report")	1	M		Root Node
>	HAS CONCEPT MOD	CODE	EV (121058, DCM, "Procedure reported")	1	M		DT (113704, DCM, "Projection X-Ray")
>>	HAS CONCEPT MOD	CODE	EV (G-C0E8, SRT, "Has Intent")	1	M		DCID 3629 "Procedure Intent" See section 9.6.1.2, value is user selectable from Additional Info screen.
>	CONTAINS	CODE	EV (122142, DCM, "Acquisition Device Type")	1	U		DT (113704, DCM, "Projection X-Ray")
>		INCLUDE	DTID 1002 "Observer Context"	1	M		See section 9.7.1.2
>	HAS OBS CONTEXT	CODE	EV (113705, DCM, "Scope of Accumulation")	1	M		DCID 10000 "Scope of Accumulation"
>>	HAS PROPERTIES	UIDREF	DCID 10001 "UID Types"	1	M		Value generated by the system.
>	CONTAINS	CODE	EV("113945, DCM, "X-Ray Detectpr Data Available")	1	U		Value of (R-0038D, SRT, "Yes")
>	CONTAINS	CODE	EV("113943, DCM, "X-Ray Source Data Available")	1	U		Value of (R-0038D, SRT, "Yes")
>	CONTAINS	CODE	EV("113943, DCM, "X-Ray Mechanical Data Available")	1	U		Value of (R-0038D, SRT, "Yes")
>	CONTAINS	INCLUDE	DTID 10002 "Accumulated X-Ray Dose"	1	MC	IFF Single Plane system	\$Plane = EV (113622, DCM, "Single Plane"). See section 0.

NL	Rel with Parent	VT	Concept Name	VM	Req Type	Condition	Value Set Constraint
>	CONTAINS	INCLUDE	DTID 10003 "Irradiation Event X-Ray Data"	1-n	MC	Condition met	All Irradiation events from the exam are recorded. See section 9.7.1.4.
>	CONTAINS	TEXT	EV (121106, DCM, "Comment")	1	U		Comment from Patient Information screen.
>	CONTAINS	IMAGE	EV (121342,, DCM, "Dose Image")	1-n	U		Any image stored to PACS from the exam.
>	CONTAINS	CODE	EV (113854, DCM,"Source of Dose Information")	1	M		DT (113940, DCM, "System Calculated")

9.7.1.2 Template ID 1001 Observer Context

Only one observer context instance is contained in the report.

NL	Rel with Parent	VT	Concept Name	VM	Req Type	Condition	Value Set Constraint
>	HAS OBS CONTEXT	CODE	EV (121005, DCM,"Observer Type")	1	M	Observer is device	DT (121007, DCM, "Device")
>		UIDREF	EV (121012, DCM, "Device Observer UID")	1	M		UID of Device
>		TEXT	EV (121013, DCM, "Device Observer Name")	1	U		Station Name entered by the user
>		TEXT	EV (121014, DCM, "Device Observer Manufacturer")	1	U		GE Healthcare Surgery
>		TEXT	EV (121015, DCM, "Device Observer Model Name")	1	U		Model Name of the system
>		TEXT	EV (121015, DCM, "Device Observer Serial Number")	1	U		Serial Number of the system
>		TEXT	EV (121017, DCM, "Device Observer Physical Location During Observation")	1	U		Station Name entered by the user

9.7.1.3 Template ID 10002 Accumulated X-Ray Dose

NL	Rel with Parent	VT	Concept Name	VM	Req Type	Condition	Value Set Constraint
		CONTAINER	EV (113702, DCM, "Accumulated X-Ray Dose Data")	1	M		
>	HAS CONCEPT MOD	CODE	EV (113764, DCM, "Acquisition Plane")	1	M		Single Plane
>	CONTAINS	CONTAINER	EV (122505, DCM, "Calibration")	1-n	MC	If the user saves the values in Quality Control Mode.	This container will be present with the values from the last Quality Control save operation.
>>	HAS CONCEPT MOD	CODE	EV(113794, DCM, "Dose Measurement Device")	1	M	Defaults to value from DCID 10010 Dose Measurement Devices value.	Value set to "SRT, A-2C090, Dosimeter"
>>	CONTAINS	DATETIME	EV(113723, DCM, "Calibration DateTime")	1	M	Value set when Quality Control Mode save is performed.	
>>	CONTAINS	NUM	EV(122322, DCM, "Calibration Factor")	1	M	Value set by user in Quality Control Mode.	No units.
>>	CONTAINS	NUM	EV(113763, DCM, "Calibration Uncertainty")	1	M	Value set by user in Quality Control Mode.	EV (% UCUM, "Percent")
>>	CONTAINS	TEXT	EV(113724, DCM, "Calibration Responsible Party")	1	M	Value set by user in Quality Control Mode.	
>>	CONTAINS	TEXT	EV(113720, DCM, "Calibration Protocol")	1	U	Value set by user in Quality Control Mode.	

NL	Rel with Parent	VT	Concept Name	VM	Req Type	Condition	Value Set Constraint
>		INCLUDE	DTID 10004 "Accumulated Fluoroscopy and Acquisition Projection X-Ray Dose"	1	M	Projection X-RAY and Row 4 is absent	See section 9.7.1.3.1.
>		INCLUDE	DTID 10007 "Accumulated Total Projection Radiography Dose"	1	M	Projection X-RAY and Row 4 is absent	See section 9.7.1.3.2.
>		INCLUDE	DTID 1021 "DeviceParticipant"	1	MC	Irradiation device is the recording device	Present. See section 9.7.1.3.4

9.7.1.3.1 Template ID 10004 Accumulated Fluoroscopy and Acquisition Projection X-Ray Dose

NL	Rel with Parent	VT	Concept Name	VM	Req Type	Condition	Value Set Constraint
		NUM	EV (113726, DCM, "Fluoro Dose Area Product Total")	1	MC	Fluoroscopy provided by system	Units - Gy.m2
		NUM	EV (113728, DCM, "Fluoro Dose (RP) Total")	1	MC	Fluoroscopy provided by system	Units - Gy
		NUM	EV (113730, DCM, "Total Fluoro Time")	1	M	Projection X-RAY and Row 4 is absent	Units - s (seconds)
		NUM	EV (113727, DCM, "Acquisition Dose Area Product Total")	1	M	Digital Spot and Digital Cine	Units - Gy.m2
		NUM	EV (113729, DCM, "Acquisition Dose (RP) Total")	1	M	Digital Spot and Digital Cine	Units - Gy
		NUM	EV (113730, DCM, "Total Acquisition Time")	1	M	Digital Spot and Digital Cine	Units - s (seconds)

9.7.1.3.2

9.7.1.3.3 Template ID 10007 Accumulated Total Projection Radiography Dose

NL	Rel with Parent	VT	Concept Name	VM	Req Type	Condition	Value Set Constraint
		NUM	EV (113722, DCM, "Dose Area Product Total")	1	M		Units - Gy.m2
		NUM	EV (113725, DCM, "Dose (RP) Total")	1	MC	Dose system calculated.	Units - Gy
		NUM	EV (113737, DCM, "Distance Source to Reference Point")	1	U		Units - mm Data found in each irradiation event
		NUM	EV (113731, DCM, "Total Number of Radiographic Frames")	1	U		Units - no units.
		NUM	EV (113780, DCM, "Reference Point Definition")	1	MC	Have Acquisition Dose (RP) Total	Units - mm. Data found in each irradiation event

9.7.1.3.4 Template ID 1021 Device Participant

NL	Rel with Parent	VT	Concept Name	VM	Req Type	Condition	Value Set Constraint
		CODE	EV (113876, DCM, "Device Role in Procedure")	1	M		"Irradiating Device"
>		NUM	EV (113877, DCM, "Device Name")	1	U		System Station Name
>		NUM	EV (113878, DCM, "Device Manufacturer")	1	M		"GE Healthcare Surgery"
>		NUM	EV (113879, DCM, "Device Model Name")	1	M		Set to Product name
>		NUM	EV (113880, DCM, "Device Serial Number")	1	M		Set to device serial number

NL	Rel with Parent	VT	Concept Name	VM	Req Type	Condition	Value Set Constraint
>		NUM	EV (113881, DCM, "Device Observer UID")	1	M		Set to device unique value using the GEHC Root, location of manufacture information.

9.7.1.4 Template ID 10003 Irradiation Event X-Ray Data

NL	Rel with Parent	VT	Concept Name	VM	Req Type	Condition	Value Set Constraint
		CONTAINER	EV (113706, DCM, "Irradiation Event X-Ray Data")	1	M		
>	HAS CONCEPT MOD	CODE	EV (113764, DCM, "Acquisition Plane")	1	M		(113622, DCM, "Single Plane")
>	CONTAINS	UIDREF	EV (113769, DCM, "Irradiation Event UID")	1	M		Generated by the system
>	CONTAINS	DATETIME	DT (111526, DCM, "DateTime Started")	1	M		DateTime of the event
>	CONTAINS	CODE	EV (113721, DCM, "Irradiation Event Type")	1	M		Set to (P5-06000, SRT, "Fluoroscopy") for all system X-Ray modes except for Digital Spot
>	CONTAINS	TEXT	EV (125203, DCM, "Acquisition Protocol")	1	U		The Protocol Description text from the additional information screen. MWL Protocol Code sequence used if available.
>	CONTAINS	CODE	EV (123014, SRT, "Patient Table Relationship")	1	U		The value set for the from the user interface conforming to DCID 21 "Patient Equipment Relationship"

NL	Rel with Parent	VT	Concept Name	VM	Req Type	Condition	Value Set Constraint
>	CONTAIN S	CODE	EV (123014, SRT, "Patient Orientation")	1	U		The value set for the from the user interface conforming to DCID 19 "Patient Orientation"
>>	CONTAIN S	CODE	EV (123014, SRT, "Patient Orientation Modifier")	1	M		The value set for the from the user interface conforming to DCID 20 "Patient Orientation Modifier"
>	CONTAIN S	CODE	EV (123014, SRT, "Target Region")	1	U		The value set for the Anatomic Region using the values defined in section 6.5.1.1
>	CONTAIN S	NUM	EV (122130, DCM, "Dose Area Product")	1	MC	Projection X-Ray	Units - Gy.m2
>	CONTAIN S	NUM	EV (111636, DCM, "Entrance Exposure at RP")	1	MC	Same as 113738 so not included	
>	CONTAIN S	CODE	EV (113780, DCM, "Reference Point Definition")	1	MC		DCID Radiation Dose Reference Point (113861, DCM, "30cm in Front of Image Input Surface")
>	CONTAIN S	IMAGE	EV (113795, DCM, "Acquired Image")	1-n	MC	IFF image is stored to PACS	
>	CONTAIN S	NUM	EV (113738, DCM, "Dose (RP)")	1	MC	Projection X-Ray	Units - Gy
>	CONTAIN S	NUM	EV (111631, DCM, "Average Glandular Dose")	1	MC	Not present - This is not a Mammography system.	
>	CONTAIN S	CODE	EV (113732, DCM, "Fluoro Mode")	1	UC		DCID 10004 "Fluoro Modes" (Continuous or Pulsed depending on what mode was used)

NL	Rel with Parent	VT	Concept Name	VM	Req Type	Condition	Value Set Constraint
>	CONTAIN S	NUM	EV (113791, DCM, "Pulse Rate")	1	MC	IFF Fluoro Mode == Pulsed	Units - pulse/s
>	CONTAIN S	NUM	EV (113768, DCM, "Number of Pulses")	1	MC	IFF Fluoro Mode == Pulsed	no units
>	CONTAIN S	NUM	EV (113793, DCM, "Pulse Width")	1	U	IFF Fluoro Mode == Pulsed	Average width: Units - ms (milliseconds)
>	CONTAIN S	NUM	EV (113742, DCM, "Irradiation Duration")	1	U		Units - s (seconds)
>	CONTAIN S	NUM	EV (113733, DCM, "KVP")	1	U		Average kVp
>	CONTAIN S	NUM	EV (113734, DCM, "X-Ray Tube Current")	1	MC		Average mA
>	CONTAIN S	NUM	EV (113767, DCM, "Average X-Ray Tube Current")	1	U		Average mA
>	CONTAIN S	NUM	EV (113824, DCM, "Exposure Time")	1	MC		Units - ms
>	CONTAIN S	NUM	EV (113736, DCM, "Exposure")	1	MC		Total for the event. Units - uA.s
>	CONTAIN S	NUM	EV (113766, DCM, "Focal Spot Size")	1	U		Units - mm
>	CONTAIN S	CODE	EV (111632, DCM, "Anode Target Material")	1	U		DCID 10016 "Anode Target Material" - Tungsten
>		CONTAINER	EV (113771, DCM, "X-Ray Filters")	1	U		
>>	CONTAIN S	CODE	EV (113772, DCM, "X-Ray Filter Type")	1	U		DCID 10007 "X-Ray Filter Types"
>>	CONTAIN S	CODE	EV (113757, DCM, "X-Ray Filter Material")	1	U		DCID 10006 "X-Ray Filter Materials"
>>	CONTAIN S	NUM	EV (113758, DCM, "X-Ray Filter Thickness Minimum")	1	U		Units - mm
>>	CONTAIN S	NUM	EV (113773, DCM, "X-Ray Filter Thickness Maximum")	1	U		Units - mm
>	CONTAIN S	NUM	EV (113790, DCM, "Collimated Field Area")	1	U		Units - m2

NL	Rel with Parent	VT	Concept Name	VM	Req Type	Condition	Value Set Constraint
>	CONTAIN S	CODE	EV (111635, DCM, "X-RayGrid")	1	U		DCID 10017 "X-Ray Grid" - Fixed
>	CONTAIN S	NUM	EV (112011, DCM, "Positioner Primary Angle")	1	UC		Units - deg. Set to 'Value unknown' for all but MD systems.
>	CONTAIN S	NUM	EV (112012, DCM, "Positioner Secondary Angle")	1	UC		Units - deg. Set to 'Value unknown' for all but MD systems.
>	CONTAIN S	NUM	EV (113740, DCM, "Positioner Primary End Angle")	1	UC		Units - deg. Set to 'Value unknown' for all but MD systems.
>	CONTAIN S	NUM	EV (113790, DCM, "Positioner Secondary End Angle")	1	UC		Units - deg. Set to 'Value unknown' for all but MD systems.

9.7.2 Standard Extended Templates

The Product does not supports extensions to the standard templates for SOP Instances created by this product. Extensions or restrictions are indicated by **bold text**.

10. MODALITY WORKLIST QUERY IMPLEMENTATION

10.1 INTRODUCTION

This section specifies the use of the DICOM Modality Worklist Information Model used to organize data and against which a Modality Worklist Query will be performed.

10.2 OEC ELITE MAPPING OF DICOM ENTITIES

The OEC Elite maps DICOM Information Entities to local Information Entities in the product's database and user interface.

TABLE 10-1
MAPPING OF DICOM ENTITIES TO OEC ELITE ENTITIES

DICOM	OEC Elite Entity
Scheduled Procedure Step	Exam
Requested Procedure	Exam
Imaging Service Request	Exam
Visit	Exam
Patient	Patient

10.3 WORKLIST QUERY MODULE TABLE

See DICOM PS 3.3 and PS 3.4 for a complete definition of the entities, modules, and attributes.

TABLE 10-2
MODALITY WORKLIST INFORMATION MODEL MODULES

Entity Name	Module Name	Reference
Scheduled Procedure Step	SOP Common	10.4.1.1
	Scheduled Procedure Step	10.4.1.2
Requested Procedure	Requested Procedure	0
Imaging Service Request	Imaging Service Request	10.4.3.1
Visit	Visit Identification	Not used.
	Visit Status	Not used.
	Visit Relationship	Not used.
	Visit Admission	10.4.4.1
Patient	Patient Relationship	Not used.
	Patient Identification	10.4.5.1
	Patient Demographic	10.4.5.2
	Patient Medical	10.4.5.3

10.4 WORKLIST QUERY MODULE DEFINITIONS

Please refer to DICOM Standard PS 3.3. (Information Object Definitions) for a description of each of the query key attributes contained within the Modality Worklist Information Model.

10.4.1 Common Scheduled Procedure Step Entity Modules

10.4.1.1 SOP Common Module

TABLE 10-3
SOP COMMON MODULE ATTRIBUTES

Attribute Name	Tag	Expected Matching Key Type	Expected Returned Key Type	Mapped into Instance	Note
Specific Character Set	(0008,0005)	O	1C	No	Checked only to allow data of supported character sets.

10.4.1.1.1 Specific Character Set

The attribute Specific Character Set (0008,0005) will be sent. Only non-ASCII characters that may be entered from the console keyboard, as described in Section 2.13, may be included in the matching key value.

The AE will use only the supported Specific Character Set value returned in a Scheduled Procedure Step Identifier in the images created pursuant to that Scheduled Procedure Step. Text attributes, including Patient and Physician names, that include non-ASCII characters will be displayed as described in Section 2.13.

10.4.1.2 Scheduled Procedure Step Module

TABLE 10-4
SCHEDULED PROCEDURE STEP MODULE ATTRIBUTES

Attribute Name	Tag	Expected Matching Key Type	Expected Returned Key Type	Mapped into Instance / MPPS	Note
Scheduled Procedure Step Sequence	(0040,0100)	R	1	No/No	
>Scheduled Station AE Title	(0040,0001)	R	1	No/No	Single Value matching is supported for this data element. The matching value is dynamically configurable by the user on the Schedule Filter screen.
>Scheduled Procedure Step Start Date	(0040,0002)	R	1 *	No/No	Range matching is supported for this data element. The range value is dynamically configurable on the Scheduled Exams screen.
>Scheduled Procedure Step Start Time	(0040,0003)	R	1 *	No/No	Value is always sent as ""
>Modality	(0008,0060)	R	1 *	No/Yes	Matching is supported and can be set to XA, RF, SC, CR or All(which is blank in the request). The modality is determined by the DICOM Server alias configuration on the OEC Workstation.

Attribute Name	Tag	Expected Matching Key Type	Expected Returned Key Type	Mapped into Instance / MPPS	Note
>Scheduled Performing Physician's Name	(0040,0006)	R	2 *	Yes/Yes (to Performing Physician's Name)	Wildcard matching is supported for this data element. User can enter characters and a wildcard character ('*') is automatically added to the end of the last and first name data entered. Displayed on Patient information screen.
>Scheduled Procedure Step Description	(0040,0005)	O	1C	Yes/Yes	Displayed on Additional information screen.
>Scheduled Station Name	(0040,0010)	O	2	No/Yes (to Performed Station Name)	Single Value matching is supported for this data element. The matching value is dynamically configurable by the user on the Schedule Filter screen.
>Scheduled Protocol Code Sequence	(0040,0008)	O	1C	Yes/Yes (to Performed Series Sequence)	
>>Code Value	(0008,0100)	O	1	Yes/Yes	Displayed on Additional information screen.
>>Coding Scheme Designator	(0008,0102)	O	1	Yes/Yes	
>>Code Meaning	(0008,0104)	O	3	Yes/Yes	Displayed on Additional information screen.
>Scheduled Procedure Step ID	(0040,0009)	O	1 *	Yes/Yes	Displayed on Additional information screen.
>Requested Contrast Agent	(0032,1070)	O	2C	No/No	Currently not used in the Image or displayed on the screen.

Note: * in the *Expected Return Key Type* column indicates that this information is displayed on screen, if available

10.4.1.2.1 Scheduled Station AE Title

Note: The RIS generally only knows one AE Title for the modality - the one that will be scheduled (identified in the MWL key), that is the source of the images (C-Store), that is identified as the performer in the MPPS, and that will respond to a C-Echo. That AE Title is presumably the DICOM image sending AE, not the Worklist Client (whose only role is to query the MWL). The Elite Workstation AE has the same AE Title for all DICOM services.

10.4.2 Common Requested Procedure Entity Modules

Unless specified otherwise all attributes listed are requested with a blank value.

10.4.2.1 Requested Procedure Module

TABLE 10-5
REQUESTED PROCEDURE MODULE ATTRIBUTES

Attribute Name	Tag	Expected Matching Key Type	Expected Returned Key Type	Mapped into Instance / MPPS	Note
Requested Procedure ID	(0040,1001)	O	1 *	Yes / Yes	The system sends the characters entered by the user. Wildcard matching is supported if the user types '?' for any single character or '*' for any multiple characters. This assumes that the server supports wildcard processing on this attribute. No truncation of this value occurs in the transfer of this value. The display on the scheduled exams screen of this value is truncated and will be shown with an elipsis (...) to show the truncation.
Requested Procedure Description	(0032,1060)	O	1C *	Yes / Yes	No truncation of this value occurs in the transfer of this value. The display on the scheduled exams screen of this value is truncated and will be shown with an elipsis (...) to show the truncation.
Requested Procedure Code Sequence	(0032,1064)	O	1C	Yes / Yes	Only mapped to Radiation Dose Structured Report.
>Code Value	(0008,0100)	O	1	Yes / Yes	Displayed on Patient Information.
>Coding Scheme Designator	(0008,0102)	O	1	Yes / Yes	Displayed on Patient Information.
>Code Meaning	(0008,0104)	O	3 *	Yes / Yes	Displayed on Patient Information.
Study Instance UID	(0020,000D)	O	1	Yes / Yes	
Referenced Study Sequence	(0008,1110)	O	2	Yes / Yes	Used to support Retrieve screen.
>Referenced SOP Class UID	(0008,1150)	O	1C	Yes / Yes	See section 2.3.1 for the list of SOP Class UIDs supported by the Elite Workstation.
>Referenced SOP Instance UID	(0008,1155)	O	1C	Yes / Yes	
Reason for the Requested Procedure	(0040,1002)	O	3	Yes / No	

Note: * in the *Expected Return Key Type* column indicates that this information is displayed on screen, if available

10.4.2.1.1 Study Instance UID

The product does support grouped procedures. If the system does not get a Study Instance UID in the response, the system will generate one.

10.4.3 Common Imaging Service Request Entity Modules

Unless specified otherwise all attributes listed are requested with a blank value.

10.4.3.1 Imaging Service Request Module

TABLE 10-6
IMAGING SERVICE REQUEST MODULE ATTRIBUTES

Attribute Name	Tag	Expected Matching Key Type	Expected Returned Key Type	Mapped into Instance / MPPS	Note
Accession Number	(0008,0050)	0	2 *	Yes / Yes	The system sends the characters entered by the user. Wildcard matching is supported if the user types '?' for any single character or '*' for any multiple characters. This assumes that the server supports wildcard processing on this attribute. No truncation of this value occurs in the transfer of this value or in the display of the Scheduled exam screen.
Referring Physician's Name	(0008,0090)	0	2 *	Yes / Yes	This value will be used if the Scheduled Performing Physician attribute is blank.
Placer Order Number / Imaging Service Request	(0040,2016)	0	3	Yes / Yes	This value is not displayed on the system.
Filler Order Number / Imaging Service Request	(0040,2017)	0	3	Yes / Yes	This value is not displayed on the system.

Note: * in the *Expected Return Key Type* column indicates that this information is displayed on screen, if available

10.4.4 Common visit Entity Modules

The product sends Visit Admission Entity module attributes.

10.4.4.1 Visit Admission

TABLE 10-7
VISIT ADMISSION MODULE ATTRIBUTES

Attribute Name	Tag	Expected Matching Key Type	Expected Returned Key Type	Mapped into Instance / MPPS	Note
Admitting Diagnoses Description	(0008,1080)	0	3	Yes / No	Not displayed on the product.
Admitting Diagnoses Code Sequence	(0008,1084)	0	3	Yes / No	
>Code Value	(0008,0100)	0	1	Yes / No	
>Coding Scheme Designator	(0008,0102)	0	1	Yes / No	
>Code Meaning	(0008,0104)	0	3 *	Yes / No	

Note: * in the *Expected Return Key Type* column indicates that this information is displayed on screen, if available

10.4.5 Common Patient Entity Modules

Unless specified otherwise all attributes listed are requested with a blank value.

10.4.5.1 Patient Identification

TABLE 10-8
PATIENT IDENTIFICATION MODULE ATTRIBUTES

Attribute Name	Tag	Expected Matching Key Type	Expected Returned Key Type	Mapped into Instance / MPPS	Note
Patient's Name	(0010,0010)	R	1 *	Yes / Yes	Wildcard matching is supported for this data element. The matching value is dynamically configurable. No truncation of this value occurs in the transfer of this value to the Instance. The display on the scheduled exams screen of this value is truncated and will be shown with an elipsis (...) to show the truncation. The value is displayed in full on the Patient Information screen.
Patient ID	(0010,0020)	R	1 *	Yes / Yes	Single Value matching is supported for this data element and the matching value is dynamically configurable. No truncation of this value occurs in the transfer of this value to the Instance. The display on the scheduled exams screen of this value is truncated and will be shown with an elipsis (...) to show the truncation. The value is displayed in full on the Patient Information screen.
Other Patient IDs	(0010,1000)	O	3	No / No	Displayed on the Previous Exams screen
Issuer of Patient ID	(0010,0021)	O	3	Yes / Yes	Not displayed
Issuer of Patient ID Qualifiers Sequence	(0010,0024)	O	3	Yes / Yes	Not displayed

Note: * in the *Expected Return Key Type* column indicates that this information is displayed on screen, if available

10.4.5.2 Patient Demographic

TABLE 10-9
PATIENT DEMOGRAPHIC MODULE ATTRIBUTES

Attribute Name	Tag	Expected Matching Key Type	Expected Returned Key Type	Mapped into Instance / MPPS	Note
Patients Birth Date	(0010,0030)	0	2 *	Yes / Yes	No truncation of this value occurs in the transfer of this value to the Instance. The data is displayed on the Patient Information screen.
Patient's Sex	(0010,0040)	0	2 *	Yes / Yes	No truncation of this value occurs in the transfer of this value to the Instance. The data is displayed on the Patient Information screen.
Patient's Weight	(0010,1030)	0	2 *	Yes / No	Displayed on Additional Information screen.
Patient's Size	(0010,1020)	0	3 *	Yes / No	Displayed on Additional Information screen.
Patient's Age	(0010,1010)	0	3 *	Yes / No	Displayed on Additional Information screen.

Note: * in the *Expected Return Key Type* column indicates that this information is displayed on screen, if available

10.4.5.3 Patient Medical

TABLE 10-10
PATIENT MEDICAL MODULE ATTRIBUTES

Attribute Name	Tag	Expected Matching Key Type	Expected Returned Key Type	Mapped into Instance / MPPS	Note
Pregnancy Status	(0010,21C0)	0	2 *	No / No	Displayed on the Patient Information screen.
Medical Alerts	(0010,2000)	0	2	No / No	Not displayed
Contrast Allergies	(0010,2110)	0	2	No / No	Not displayed

Note: * in the *Expected Return Key Type* column indicates that this information is displayed on screen, if available

11. MODALITY PERFORMED PROCEDURE STEP IMPLEMENTATION

11.1 INTRODUCTION

This section specifies the use of the DICOM Modality Performed Procedure Step information to be communicated to the Hospital/Radiology information system.

This feature works in conjunction with DICOM Modality Worklist feature, if installed. However the conformance of this feature is independent of Modality Worklist feature. For information on conformance of Modality Worklist feature to DICOM standard please refer to the appropriate section in this document.

11.2 RELATIONSHIP BETWEEN SCHEDULED AND PERFORMED PROCEDURE STEPS

The OEC Elite supports a one-to-one relationship between Scheduled Procedure Step and PPS, a multiple-to-one relationship (aka Group Case), a one/multiple-to-multiple relationship (aka Append Case or Post-processing), and a zero-to-one relationship (aka Unscheduled Case or Acquisition without MWL Data).

11.3 MODALITY PERFORMED PROCEDURE STEP MODULE TABLE

See DICOM PS 3.3 and PS 3.4 for a complete definition of the entities, modules, and attributes.

TABLE 11-1
MODALITY PERFORMED PROCEDURE STEP MODULES

Module Name	Reference
SOP Common	0
Performed Procedure Step Relationship	11.4.2
Performed Procedure Step Information	11.4.3
Image Acquisition Results	11.4.4
Billing and Material Management Codes	11.4.5

11.4 MODALITY PERFORMED PROCEDURE STEP MODULE DEFINITIONS

Please refer to DICOM Standard PS 3.3. (Information Object Definitions) for a description of each of the attributes contained within the Modality Performed Procedure Step Information Object Definition.

11.4.1 SOP Common Module

TABLE 11-2
SOP COMMON MODULE ATTRIBUTES

Attribute Name	Tag	Type for SCU N-CREATE	Type for SCU N-SET	Use
Specific Character Set	(0008,0005)	1C	1C	Used to indicate character set of this message.

11.4.2 Performed Procedure Step Relationship Module

The OEC Elite product does not support post-processing PPS (i.e. with scheduled data read from images).

The following table contains data for the 'DICOM Type' of the tag and where the source of the data for that tag with or without MWL being involved.

TABLE 11-3
PERFORMED PROCEDURE STEP RELATIONSHIP MODULE ATTRIBUTES

Attribute Name	Tag	Type for SCU - N-CREATE	
		Acquisition without MWL Entry	Acquisition with MWL Entry
Scheduled Step Attributes Sequence	(0040,0270)	1, sequence containing 10 mostly empty items.	1 sequence containing 12 items populated with data from the MWL.
>Study Instance UID	(0020,000D)	1, created by the system	1, Filled with data from MWL
>Referenced Study Sequence	(0008,1110)	2, Empty sequence	2, Filled with sequence from MWL
>>Referenced SOP Class UID	(0008,1150)	1, Not sent	1, Filled from MWL
>>Referenced SOP Instance UID	(0008,1155)	1, Not sent	1, Filled from MWL
>Accession Number	(0008,0050)	2, Filled from user interface	2, Filled from MWL
>Placer Order Number/Imaging Service Request	(0040,2016)	3, Empty sequence	3, Filled from MWL
>Filler Order Number/Imaging Service Request	(0040,2017)	3, Empty sequence	3, Filled from MWL
>Requested Procedure ID	(0040,1001)	2, Empty	2, Filled from MWL
>Requested Procedure Code Sequence	(0032,1064)	3, Empty sequence	3, Filled from MWL unless the user modifies the value in the user interface then an empty sequence is sent.
>>Code Value	(0008,0100)	1, Not sent	1, Filled from MWL
>>Coding Scheme Designator	(0008,0102)	1, Not sent	1, Filled from MWL
>>Code Meaning	(0008,0104)	1, Not sent	1, Filled from MWL
>Requested Procedure Description	(0032,1060)	2, Empty	2, Filled from MWL
>Scheduled Procedure Step ID	(0040,0009)	2, Empty	2, Filled from MWL
>Scheduled Procedure Step Description	(0040,0007)	2, Empty	2, Filled from MWL

>Scheduled Protocol Code Sequence	(0040,0008)	2, Empty sequence	2, Filled with sequence from MWL
>>Code Value	(0008,0100)	1, Not sent	1, Filled from MWL
>>Coding Scheme Designator	(0008,0102)	1, Not sent	1, Filled from MWL
>>Coding Scheme Version	(0008,0103)	3, Not sent	3, Filled from MWL
>>Code Meaning	(0008,0104)	3, Not sent	3, Filled from MWL
Patient's Name	(0010,0010)	2, Filled from user interface	2, Filled from MWL
Patient ID	(0010,0020)	2, Filled from user interface	2, Filled from MWL
Issuer of Patient ID	(0010,0021)	3, Empty	3, Filled from MWL
Patient's Birth Date	(0010,0030)	2, Filled from user interface	2, Filled from MWL
Patient's Sex	(0010,0040)	2, Filled from user interface	2, Filled from MWL
Referenced Patient Sequence	(0008,1120)	2, Empty sequence	2, Empty sequence
>Referenced SOP Class UID	(0008,1150)	1, Not sent	1, Not sent
>Referenced SOP Instance UID	(0008,1155)	1, Not sent	1, Not sent
Admission ID	(0038,0010)	3, Not sent	3, Not sent
Issuer of Admission ID	(0038,0011)	3, Not sent	3, Not sent
Service Episode ID	(0038,0060)	3, Not sent	3, Not sent
Issuer of Service Episode ID	(0038,0061)	3, Not sent	3, Not sent
Service Episode Description	(0038,0062)	3, Not sent	3, Not sent

11.4.3 Performed Procedure Step Information Module

TABLE 11-4
PERFORMED PROCEDURE STEP INFORMATION MODULE ATTRIBUTES

Attribute Name	Tag	Type for SCU N-CREATE	Type for SCU N-SET	Use
Performed Procedure Step ID	(0040,0253)	1	-	Populated from MWL or from the user interface Additional Info screen. If not entered by the user, the system will create value of 'PPS Step ID'.
Performed Station AE Title	(0040,0241)	1	-	Populated from system configuration for AE Title.
Performed Station Name	(0040,0242)	2	-	Populated from system configuration for Station Name.
Performed Location	(0040,0243)	2	-	Empty value is sent.
Performed Procedure Step Start Date	(0040,0244)	1	-	Date of the first x-ray for the exam.
Performed Procedure Step Start Time	(0040,0245)	1	-	Time of the first x-ray for the exam.
Performed Procedure Step Status	(0040,0252)	1	3	Set to "IN-PROGRESS" for N-CREATE. Only one N-SET will be sent when the exam is 'ended' (completed - COMPLETED or abandoned - DISCONTINUED).
Performed Procedure Step Description	(0040,0254)	2	3	Set to value from MWL. User has the ability to enter text on Additional Info screen.
Performed Procedure Type Description	(0040,0255)	2	3	Set to value from MWL. User has the ability to enter Procedure description text on Patient Info screen.
Procedure Code Sequence	(0008,1032)	2	3	Set to value from MWL is values not modified prior to start of exam by the user. For manual data entry, User is able to enter these values on the Patient Info screen but all three values, code, designator and description (meaning) need to be present. For N-CREATE of an Append step this sequence will always be empty.
>Code Value	(0008,0100)	1	1	From MWL or user interface.
>Coding Scheme Designator	(0008,0102)	1	1	From MWL or user interface.
>Coding Scheme Version	(0008,0103)	3	3	From MWL else not sent.
>Code Meaning	(0008,0104)	3	3	From MWL or user interface.

Attribute Name	Tag	Type for SCU N-CREATE	Type for SCU N-SET	Use
Performed Procedure Step End Date	(0040,0250)	2	3	Date when the user 'ends' the exam from the user interface.
Performed Procedure Step End Time	(0040,0251)	2	3	Time when the user 'ends' the exam from the user interface.
Comments on the Performed Procedure Step	(0040,0280)	3	3	Not sent.
Performed Procedure Step Discontinuation Reason Code Sequence	(0040,0281)	3	3	The N-CREATE will always have an empty sequence sent. The N-SET will contain the sequence values the user selected from the user interface when 'abandoning' an exam.
>Code Value	(0008,0100)	1	1	Not sent for N-CREATE. Value selected from user interface for N-SET.
>Coding Scheme Designator	(0008,0102)	1	1	Not sent for N-CREATE. Value selected from user interface for N-SET.
>Coding Scheme Version	(0008,0103)	3	3	Not sent.
>Code Meaning	(0008,0104)	3	3	Not sent for N-CREATE. Value selected from user interface for N-SET.

11.4.4 Image Acquisition Results Module

TABLE 11-5
IMAGE ACQUISITION RESULTS MODULE ATTRIBUTES

Attribute Name	Tag	Type for SCU N-CREATE	Type for SCU N-SET	Use
Modality	(0008,0060)	1	-	Set to Modality sent in the MWL. Set to default configured DICOM Store server definition on the system for Manual exams else set to 'XA'.
Study ID	(0020,0010)	2	-	Set to value from MWL or value entered by the user on the Patient Info screen.
Performed Protocol Code Sequence	(0040,0260)	2	3	Set to an empty sequence for N-CREATE and N-SET in all cases.
>Code Value	(0008,0100)	1	1	Not sent.
>Coding Scheme Designator	(0008,0102)	1	1	Not sent.
>Coding Scheme Version	(0008,0103)	3	3	Not sent.
>Code Meaning	(0008,0104)	3	3	Not sent.
Performed Series Sequence	(0040,0340)	2	3	Sent with values from MWL or user interface.
>Performing Physician's Name	(0008,1050)	2	2	Set to Physician name on Patient Info screen.
>Protocol Name	(0018,1030)	1	1	Set to the value found in the Protocol Description on the Additional Info screen.
>Operator's Name	(0008,1070)	2	2	Set to a blank value.

Attribute Name	Tag	Type for SCU N-CREATE	Type for SCU N-SET	Use
>Series Instance UID	(0020,000E)	1	1	Set to the value created by the system for the series which will contain the images for the step.
>Series Description	(0008,103E)	2	2	Set to the value found in the Protocol Description on the Additional Info screen.
>Retrieve AE Title	(0008,0054)	2	2	N-CREATE will contain an empty value, N-SET will contain the value of system configured AE Title.
> Archive Requested	(0040,A494)	3	3	Not sent.
>Referenced Image Sequence	(0008,1140)	2	2	Empty sequence sent in N-CREATE. N-SET will contain list of any images stored to PACS prior to exam completion.
>>Referenced SOP Class UID	(0008,1150)	1	1	N-SET - Set to the SOP Class UID used for storage.
>>Referenced SOP Instance UID	(0008,1155)	1	1	N-SET - Set to the SOP Instance UID used for storage.
>Referenced Non-Image Composite SOP Instance Sequence	(0040,0220)	2	2	Empty sequence sent in N-CREATE. N-SET will contain the RDSR stored to PACS prior to exam completion for each step.
>>Referenced SOP Class UID	(0008,1150)	1	1	N-SET - Set to the RDSR SOP Class UID for this step.
>>Referenced SOP Instance UID	(0008,1155)	1	1	N-SET - Set to the RDSR Instance UID used for storage for this step.

11.4.5 Billing and Material Management Codes Module

TABLE 11-6
BILLING AND MATERIAL MANAGEMENT CODES MODULE ATTRIBUTES

Attribute Name	Tag	Type for SCU N-CREATE	Type for SCU N-SET	Use
Billing Procedure Step Sequence	(0040,0320)	3	3	Not sent.
> 'Code Sequence Macro'		3	3	Not sent.
Film Consumption Sequence	(0040,0321)	3	3	Not sent.
>Number of Films	(2100,0170)	3	3	Not sent.
>Medium Type	(2000,0030)	3	3	Not sent.
>Film Size ID	(2010,0050)	3	3	Not sent.
Billing Supplies and Devices Sequence	(0040,0324)	3	3	Not sent.
>Billing Item Sequence	(0040,0296)	3	3	Not sent.
>> 'Code Sequence Macro'	(0040,0303)	3	3	Not sent.
>Quantity Sequence	(0040,0293)	3	3	Not sent.

Attribute Name	Tag	Type for SCU N-CREATE	Type for SCU N-SET	Use
>>Quantity	(0040,0294)	3	3	Not sent.
>>Measuring Units Sequence	(0040,0295)	3	3	Not sent.
>>> 'Code Sequence Macro'		3	3	Not sent.

12. STORAGE COMMITMENT PUSH MODEL IMPLEMENTATION

12.1 STORAGE COMMITMENT PUSH MODEL INFORMATION OBJECT DEFINITION

Please refer to DICOM Part 3 (Information Object Definitions) for a description of each of the attributes contained within the Storage Commitment Information Object.

The Storage Commitment Information Object is used both for N-ACTION Storage Commitment Requests by the SCU and N-EVENT-REPORT Storage Commitment Notifications by the SCP.

12.1.1 STORAGE COMMITMENT MODULE FOR N-ACTION

TABLE 12-1
STORAGE COMMITMENT MODULE FOR N-ACTION

Attribute Name	Tag	SCU Use	SCP Use
Transaction UID	(0008,1195)	Product generates a transaction UID for each instance stored to PACS. Each C-STORE is paired with an N-ACTION. If the N-ACTION is not completed the product will report a storage failure.	The AE does not act as an SCP for Storage Commit.
Storage Media File-Set ID	(0088,0130)	Not used	Not used
Storage Media File-Set UID	(0088,0140)	Not used	Not used
Referenced SOP Sequence	(0008,1199)	Only one pair will be present.	
>Referenced SOP Class UID	(0008,1150)	Set to the modality configured in the product.	
>Referenced SOP Instance UID	(0008,1155)	Set to the value generated by the product.	
>Storage Media File-Set ID	(0088,0130)	Not used	Not used
>Storage Media File-Set UID	(0088,0140)	Not used	Not used

12.1.2 STORAGE COMMITMENT MODULE FOR N-EVENT-REPORT

TABLE 12-2
STORAGE COMMITMENT MODULE FOR N-EVENT-REPORT

Attribute Name	Tag	SCU Use	SCP Use
Transaction UID	(0008,1195)	The AE uses the attribute to confirm storage of the instance and marks the instance as confirmed on the Images screen.	The AE does not act as an SCP for Storage Commit.
Retrieve AE Title	(0008,0054)	Not used	Not used
Storage Media File-Set ID	(0088,0130)	Not used	Not used
Storage Media File-Set UID	(0088,0140)	Not used	Not used
Referenced SOP Sequence	(0008,1199)	The AE uses the attribute to confirm storage of the instance and marks the instance as confirmed on the Images screen.	
>Referenced SOP Class UID	(0008,1150)		
>Referenced SOP Instance UID	(0008,1155)		
>Retrieve AE Title	(0008,0054)	Not used	Not used
>Storage Media File-Set ID	(0088,0130)	Not used	Not used
>Storage Media File-Set UID	(0088,0140)	Not used	Not used
Failed SOP Sequence	(0008,1198)	The AE uses the attribute to confirm failed storage of the instance.	
>Referenced SOP Class UID	(0008,1150)		
>Referenced SOP Instance UID	(0008,1155)		
>Failure Reason	(0008,1197)	See Section 12.1.2.1 for the list of processed values.	Not used

12.1.2.1 Processing of Failure Reason when received in a N-Event-Report

When receiving a N-Event-Report request with a Event Type ID equal to 2, meaning that Storage Commitment is complete, but failure exists, following is the set of value that this Storage Commitment SCU AE is able to process:

Failure Reason	Meaning	Application Behavior When Receiving Reason Code
0110H	Processing failure	Display error status in Transfer status screen.
0112H	No such object instance	Display error status in Transfer status screen.
0213H	Resource limitation	Display error status in Transfer status screen.
0122H	Referenced SOP Class not supported	Display error status in Transfer status screen.
0119H	Class / Instance conflict	Display error status in Transfer status screen.
0131H	Duplicate transaction UID	Display error status in Transfer status screen.
*	Other Failure Reason code values	Display error status in Transfer status screen.

13. BASIC DIRECTORY INFORMATION OBJECT IMPLEMENTATION

13.1 IOD MODULE TABLE

Table 13-1 identifies the defined modules within the entities which comprise the Basic Directory IOD. Modules are identified by Module Name.

See DICOM Part 3 for a complete definition of the entities, modules, and attributes.

TABLE 13-1
BASIC DIRECTORY IOD MODULES

Entity Name	Module Name	Reference
File Set Identification	File Set Identification	13.2.1
Directory Information	Directory Information	13.2.2

The FSC of this implementation creates a Directory Information Module, and an FSR supports it.

13.2 INFORMATION MODULE DEFINITIONS

Please refer to DICOM Standard Part 3 (Information Object Definitions) for a description of each of the entities and modules contained within the Basic Directory Information Object.

The following modules are included to convey Enumerated Values, Defined Terms, and Optional Attributes supported. Type 1 & Type 2 Attributes are also included for completeness and to define what values they may take and where these values are obtained from. It should be noted that they are the same ones as defined in the DICOM Standard Part 3 (Information Object Definitions). Also note that Attributes not present in tables are not supported.

13.2.1 File Set identification Module

TABLE 13-2
FILE-SET IDENTIFICATION MODULE

Attribute Name	Tag	Type	Attribute Description
File-set ID	(0004,1130)	2	The AE creates a value when the Basic Directory IOD does not exist. The value is set to "GE_YYYYMMDDHHMM".
Specific Character Set of File-set Descriptor File	(0004,1142)	1C	Not used

13.2.2 Directory Information Module

TABLE 13-3
DIRECTORY INFORMATION MODULE

Attribute Name	Tag	Type	Attribute Description
Offset of the First Directory Record of the Root Directory Entity	(0004,1200)	1	Is set
Offset of the Last Directory Record of the Root Directory Entity	(0004,1202)	1	Is set
File-set Consistency Flag	(0004,1212)	1	FSC/FSU: Set to value 0000H: no known inconsistencies
Directory Record Sequence	(0004,1220)	2	Is created by FSC
>Offset of the Next Directory Record	(0004,1400)	1C	Is set
>Record In-use Flag	(0004,1410)	1C	FSC/FSU Is set to FFFFH FSR: A value of 0000H: imply skipping this record.
>Offset of Referenced Lower-Level Directory Entity	(0004,1420)	1C	Is set
>Directory Record Type	(0004,1430)	1C	The values supported by FSC and FSU and are: PATIENT STUDY SERIES IMAGE SR DOCUMENT The values supported by the FSR are: PATIENT STUDY SERIES IMAGE
>Private Record UID	(0004,1432)	1C	Not used
>Referenced File ID	(0004,1500)	1C	Set when the record type is IMAGE or SR DOCUMENT. It contains the relative path to the file that represents the instance.
>Referenced SOP Class UID in File	(0004,1510)	1C	Set when the record type is IMAGE or SR DOCUMENT. Set to the SOP Class UID of the instance stored

Attribute Name	Tag	Type	Attribute Description
>Referenced SOP Instance UID in File	(0004,1511)	1C	Set when the record type is IMAGE or SR DOCUMENT. Set to the SOP Instance UID of the instance stored
>Referenced Transfer Syntax UID in File	(0004,1512)	1C	Set when the record type is IMAGE or SR DOCUMENT. Set to the transfer syntax UID of the instance stored
> Referenced Related General SOP Class UID in File	(0004,151A)	1C	Not used
>Record Selection Keys			See 0.

13.2.3 Definition of Specific Directory Records

13.2.3.1 Patient Directory Record Definition

**TABLE 13-4
PATIENT KEYS**

Key	Tag	Type	Attribute Description
Specific Character Set	(0008,0005)	1C	FSC/ FSU writes as described in Section 2.13. FSR uses this to filter data which is not understood by the AE.
Patient's Name	(0010,0010)	2	Is set by the FSC/FSU as defined in section 4.4.1.1. FSR support reads the value as stored.
Patient ID	(0010,0020)	1	Is set by the FSC/FSU as defined in section 4.4.1.1. FSR support reads the value as stored.
Patient's Birth Date	(0010,0030)	3	Is set by the FSC/FSU as defined in section 4.4.1.1. FSR support reads the value as stored.
Patient's Sex (Gender)	(0010,0030)	3	Is set by the FSC/FSU as defined in section 4.4.1.1. FSR support reads the value as stored.

13.2.3.2 Study Directory Record Definition

**TABLE 13-5
STUDY KEYS**

Key	Tag	Type	Attribute Description
Specific Character Set	(0008,0005)	1C	FSC/ FSU writes as described in Section 2.13. FSR uses this to filter data which is not understood by the AE.
Study Date	(0008,0020)	1	Is set by the FSC/FSU as defined in section 4.4.2.1. FSR support reads the value as stored.
Study Time	(0008,0030)	1	Is set by the FSC/FSU as defined in section 4.4.2.1. FSR support reads the value as stored.
Study Description	(0008,1030)	2	Is set by the FSC/FSU as defined in section 4.4.2.1. FSR support reads the value as stored.

Study Instance UID	(0020,000D)	1C	Is set by the FSC/FSU as defined in section 4.4.2.1. FSR support reads the value as stored.
Study ID	(0020,0010)	1	Is set by the FSC/FSU as defined in section 4.4.2.1.
Accession Number	(0008,0050)	2	Is set by the FSC/FSU as defined in section 4.4.2.1. FSR support reads the value as stored.

13.2.3.3 Series Directory Record Definition

**TABLE 13-6
SERIES KEYS**

Key	Tag	Type	Attribute Description
Specific Character Set	(0008,0005)	1C	FSC/ FSU writes as described in Section 2.13. FSR uses this to filter data which is not understood by the AE. The value will be set to ISO_IR 192 if the series contains OEC Compatible data.
Modality	(0008,0060)	1	Is set by the FSC/FSU as defined in section 4.4.3.1. FSR support reads the value as stored.
Series Instance UID	(0020,000E)	1	Is set by the FSC/FSU as defined in section 4.4.3.1.
Series Number	(0020,0011)	1	Is set by the FSC/FSU as defined in section 4.4.3.1.
Icon Image Sequence	(0088,0200)	3	Not used

13.2.3.4 Image Directory Record Definition

**TABLE 13-7
IMAGE KEYS**

Key	Tag	Type	Attribute Description
Specific Character Set	(0008,0005)	1C	FSC/ FSU writes as described in Section 2.13. FSR uses this to filter data which is not understood by the AE. The value will be set to ISO_IR 192 if the SOP Class UID is Raw Data Storage SOP which is created when OEC Compatible data is written.
Instance Number	(0020,0013)	1	Is set by the FSC/FSU as defined in section 4.4.5.1.
Icon Image Sequence	(0088,0200)	3	See section 13.2.3.4.1.
>Include 'Image Pixel Macro'			See section 13.2.3.4.1.
Image Type	(0008,0008)	3	See section 4.4.5.4.1

13.2.3.4.1 Icon Image Key Definition

The icon image key is created by the FSC and updated by the FSU.

- The FSC or FSU creates a 64x64 image which represents the full size image.
- The icon is used by an FSR to display to the user enabling more timely and easier selection of images.
- Photometric Interpretation (0028,0004) MONOCHROME2 is created. FSR supports MONOCHROME1, MONOCHROME2 or PALETTE COLOR,

- Icon image size of 64 by 64 is created/supported.
- Bits Allocated (0028,0100) is set to 8 and Bits Stored (0028,0101) is set to 8 and are created/supported.

13.2.3.4.2 Raw Image data storage

The AE writes a Raw SOP Class UID instance if the user selects 'OEC Compatible' in the Media Options. This allows the user to move the image to another compatible system. For this case the Image Directory record has a private group with information needed by the AE. This is defined in section 0.

13.2.3.5 SR Document Directory Record Definition

**TABLE 13-8
SR DOCUMENT KEYS**

Key	Tag	Type	Attribute Description
Specific Character Set	(0008,0005)	1C	FSC/ FSU writes as described in Section 2.13. FSR uses this to filter data which is not understood by the AE.
Instance Number	(0020,0013)	1	Is set by the FSC/FSU as defined in section 9.4.2.1.
Completion Flag	(0040,A491)	1	Is set by the FSC/FSU as defined in section 9.4.2.1.
Verification Flag	(0040,A493)	1	Is set by the FSC/FSU as defined in section 9.4.2.1.
Content Date	(0008,0023)	1	Is set by the FSC/FSU as defined in section 9.4.2.1.
Content Time	(0008,0033)	1	Is set by the FSC/FSU as defined in section 9.4.2.1.
Verification DateTime	(0040,A030)	1C	Not present. Verification is not currently supported on the AE.
Concept Name Code Sequence	(0040,A043)	1	This information is found in section 9.4.2.2, which defines the content of the report.
Content Sequence	(0040,A730)	1C	This information is found in section 9.4.2.2, which defines the content of the report.
>Relationship Type	(0040,A010)	1	This information is found in section 9.4.2.2, which defines the content of the report.
The SR content start here			There are two "HAS CONCEPT MOD" content items; one for the type of report and one for the intent of report. This can be found in section 9.7.1.1

Note – The content sequence that the system provides, which can be modified by the user, is the 'HAS CONCEPT MOD' with 'Has Intent' and contains the value of the Procedure Intent selected by the user from the Additional Info screen.

13.3 PRIVATE DATA DICTIONARY

This private group is used in the Basic Directory Information object within an Image Record.

**TABLE 13-9
 PRIVATE CREATOR IDENTIFICATION (GEHC_OEC)**

Attribute Name	Tag	VR	VM
Private Creator	(110B,0010)	LO	1
Value 1	(110B,xx01)	LO	1
Value 2	(110B, xx10)	LO	1
Value 3	(110B, xx20)	LO	1
Value 4	(110B, xx21)	LO	1
Value 5	(110B, xx30)	LO	1
Value 6	(110B, xx31)	LO	1
Value 7	(110B, xx32)	LO	1
Value 8	(110B, xx40)	LO	1

14. PRINT MANAGEMENT IMPLEMENTATION

14.1 INTRODUCTION

This section of the DICOM Conformance Statement specifies the implementation for the specific SOP Classes supported in the Basic Grayscale Print Management Meta SOP Class, the attributes supported for both IODs and services, and the valid range of values for mandatory and optional attributes.

14.2 BASIC FILM SESSION SOP CLASS

14.2.1 Basic Film Session N-Create Attributes

This table lists the attributes that are sent in the Basic Film Session N-Create Request:

Attribute name	Tag	Use
Specific Character Set	(0008,0005)	The value is set as described in Section 2.13.
Number of Copies	(2000,0010)	This value is set by the user.
Print Priority	(2000,0020)	This value is set by the user.
Medium Type	(2000,0030)	This value is set by the user.
Film Destination	(2000,0040)	This value is set by the user.
Film Session Label	(2000,0050)	Not used
Memory Allocation	(2000,0060)	Not used
Owner ID	(2100,0160)	Not used

14.2.2 Basic Film Session N-Delete

Sent after the Presentation LUT N-Delete.

14.3 BASIC FILM BOX SOP CLASS

14.3.1 Basic Film Box N-Create Attributes

This table lists the attributes that are sent to the SCP in the Basic Film Box N-Create Request, and that are received in the Basic Film Box N-Create Response from the SCP

Attribute Name	Tag	Use
Image Display Format	(2010,0010)	Specify Enumerated Values sent and range: STANDARD\C,R The value for C and R are configured by the user from a system defined set of values on the DICOM Print configuration screen and the main user interface on the Images screen. Supported values include : 1x1, 1x2, 2x2, 2x3,3x3, 3x4, 4x4 and 4x5.
Referenced Film Session Sequence	(2010,0500)	Used
>Referenced SOP Class UID	(0008,1150)	Set to 1.2.840.10008.5.1.1.1
>Referenced SOP Instance UID	(0008,1155)	This value should be returned from SCP in N-CREATE-RSP Basic Film Session SOP Class; This value is sent to SCP in N-CREATE-RQ Basic Film Box SOP Class requesting for Basic Grayscale Image Box SOP Class Instance UID which contained in Referenced Image Box Sequence from SCP.
Referenced Image Box Sequence	(2010,0510)	Used
>Referenced SOP Class UID	(0008,1150)	Set to 1.2.840.10008.5.1.1.4
>Referenced SOP Instance UID	(0008,1155)	Received in the N-Create Response from SCP, the value is sent to SCP in N-SET-RQ Basic Grayscale Image Box SOP Class
Referenced Basic Annotation Box Sequence	(2010,0520)	Not used
>Referenced SOP Class UID	(0008,1150)	Not used
>Referenced SOP Instance UID	(0008,1155)	Not used
Film Orientation	(2010,0040)	Specify Enumerated Values sent: PORTRAIT or LANDSCAPE Configured by user in the Print Options from the Images screen.
Film Size ID	(2010,0050)	Specify Defined Terms sent: 8INX10IN 10INX12IN 10INX14IN 11INX14IN 14INX14IN 14INX17IN 24CMX30CM
Magnification Type	(2010,0060)	Not used

Attribute Name	Tag	Use
Max Density	(2010,0130)	0-400, default value is 300. User configurable.
Configuration Information	(2010,0150)	User configurable. The allowable values for a specific printer can be found in the DICOM Conformance statement of the Printer.
Referenced Presentation LUT Sequence	(2050,0500)	Used
>Referenced SOP Class UID	(0008,1150)	
>Referenced SOP Instance UID	(0008,1155)	Received in the N-Create Response from SCP, this value should be sent to SCP in N-CREATE-RQ Basic Film Box SOP Class
Annotation Display Format ID	(2010,0030)	Not used
Smoothing Type	(2010,0080)	Not used
Border Density	(2010,0100)	Specify Defined Terms or range of values of sent: BLACK or WHITE or blank
Empty Image Density	(2010,0110)	Specify Defined Terms or range of values of sent: BLACK or WHITE or blank
Min Density	(2010,0120)	Specify range of values sent. 0-400 with 0 as the default and is user configurable.
Trim	(2010,0140)	Not used
Illumination	(2010,015E)	Specify range of values sent. 0-4000 with 2000 as the default and is user configurable.
Reflected Ambient Light	(2010,0160)	Specify range of values sent. 0-400 with 10 as the default and is user configurable.
Requested Resolution ID	(2020,0050)	Not used
ICC Profile	(0028,2000)	Not used

14.3.2 Basic Film Box N-Action Attributes

Following are the Action Reply arguments that are supported if present in the N-Action response of the Basic Film Box SOP Class

Action Type Name	Action Type ID	Attribute	Tag	Usage SCU
Print	1	Referenced Print Job Sequence	(2100,0500)	Not used
		>Referenced SOP Class UID	(0008,1150)	Not used
		>Referenced SOP Instance UID	(0008,1155)	Not used
		>Print Job ID	(2100,0010)	Not used

14.4 BASIC GRAYSCALE IMAGE BOX SOP CLASS**14.4.1 Basic Grayscale Image Box Pixel N-Set Attributes**

This table lists the attributes that are sent in the Basic Grayscale Image Box N-Set Request:

Attribute Name	Tag	Use
Image Position	(2020,0010)	Value determined by the position of the image in the print layout selected by the user.
Basic Grayscale Image Sequence	(2020,0110)	
>Samples Per Pixel	(0028,0002)	Set to 1.
>Photometric Interpretation	(0028,0004)	Set to MONOCHROME2
>Rows	(0028,0010)	Set to 1280
>Columns	(0028,0011)	Set to 1280
>Pixel Aspect Ratio	(0028,0034)	Set to 1\1
>Bits Allocated	(0028,0100)	Dependent on the setting for Bit Depth set by the user 8 is sent for 8 bits depth or 16 is sent for 12 bits depth.
>Bits Stored	(0028,0101)	Dependent on the setting for Bit Depth set by the user 8 is sent for 8 bits depth or 12 is sent for 12 bits depth.
>High Bit	(0028,0102)	Dependent on the setting for Bit Depth set by the user 7 is sent for 8 bits depth or 11 is sent for 12 bits depth.
>Pixel Representation	(0028,0103)	Set to 0x0000
>Pixel Data	(7FE0,0010)	
Polarity	(2020,0020)	Not used
Magnification Type	(2010,0060)	Not used
Smoothing Type	(2010,0080)	Not used
Min Density	(2010,0120)	Not used
Max Density	(2010,0130)	Not used
Configuration Information	(2010,0150)	Not used
Requested Image Size	(2020,0030)	Not used
Requested Decimate/Crop Behavior	(2020,0040)	Not used
Referenced Presentation LUT Sequence	(2050,0500)	Not used
> Referenced SOP Class UID	(0008,1150)	Not used
> Referenced SOP Instance UID	(0008,1155)	Not used

14.5 PRINTER SOP CLASS

14.5.1 Printer N-Event-Report Attributes

The following table describes the product behavior when receiving a **N-Event-Report** request from the Printer SCP depending on the Event Type ID value.

Event Type Name	Event Type ID	Attribute	Tag	Use
Normal	1			The message is handled but ignored. N-GET used for status.
Warning	2	Printer Status Info	(2110,0020)	The message is handled but ignored. N-GET used for status.
		Film Destination	(2000,0040)	The message is handled but ignored. N-GET used for status.
		Printer Name	(2110,0030)	The message is handled but ignored. N-GET used for status.
Failure	3	Printer Status Info	(2110,0020)	The message is handled but ignored. N-GET used for status.
		Film Destination	(2000,0040)	The message is handled but ignored. N-GET used for status.
		Printer Name	(2110,0030)	The message is handled but ignored. N-GET used for status.

14.5.2 Printer N-Get Attributes

This table defines the set of attributes that this product may request using the Printer N-Get service. It also describes what is the product behavior when receiving the N-Get response from the Printer SCP.

Attribute Name	Tag	Use
Printer Status	(2110,0010)	Requested by the system. Also for each Enumerated Values, describe what is the product behaviour: NORMAL – No action WARNING – reports Supply Empty FAILURE – reports failure to user.
Printer Status Info	(2110,0020)	Requested by the system. Any status with EMPTY included is treated as an 'Out of Paper' status.
Printer Name	(2110,0030)	Requested by the system.
Manufacturer	(0008,0070)	Requested by the system.

Attribute Name	Tag	Use
Manufacturer Model Name	(0008,1090)	Requested by the system.
Device Serial Number	(0018,1000)	Requested by the system.
Software Versions	(0018,1020)	Requested by the system.
Date Of Last Calibration	(0018,1200)	Requested by the system.
Time Of Last Calibration	(0018,1201)	Requested by the system.

14.6 PRESENTATION LUT SOP CLASS

14.6.1 Presentation LUT N-Create Attributes

This table describes the list of attributes that is sent when sending a Presentation LUT N-Create message is sent to the Printer.

Attribute Name	Tag	Use
Presentation LUT Sequence	(2050,0010)	Not used
>LUT Descriptor	(0028,3002)	
>LUT Explanation	(0028,3003)	
>LUT Data	(0028,3006)	
Presentation LUT Shape	(2050,0020)	Set to "IDENTITY"

15. QUERY IMPLEMENTATION

15.1 OEC ELITE MAPPING OF DICOM ENTITIES

The OEC Elite maps DICOM Information Entities to local Information Entities in the product’s database and user interface.

TABLE 15-1
MAPPING OF DICOM ENTITIES TO OEC ELITE ENTITIES

DICOM	OEC Elite Entity
Patient	Patient
Study	Exam
Series	Exam
Image	Image

15.2 INFORMATION MODEL KEYS

Please refer to DICOM Standard PS 3.4 (Service Class Specifications) for a description of each of the levels contained within the Query/Retrieve Information Model.

15.2.1 Common Query Keys

The query key attributes specified in this section are used at all levels and in all classes of query.

TABLE 15-2
Q/R PATIENT LEVEL COMMON RETRIEVE ATTRIBUTES

Attribute Name	Tag	Type	SCU Use
Specific Character Set	(0008,0005)	-	See 15.2.1.1.1
Query Retrieve Level	(0008,0052)	-	Set to level of query: PATIENT STUDY SERIES
Retrieve AE Title	(0008,0054)	-	Attribute is not requested.
Storage Media File-set ID	(0088,0130)	-	Attribute is not requested. Returned value is ignored
Storage Media File-set UID	(0088,0140)	-	Attribute is not requested. Returned value is ignored

15.2.1.1 Q/R Common Attribute Descriptions

15.2.1.1.1 Specific Character Set

Only non-ASCII characters that may be entered from the console keyboard, as described in Section 2.13, may be included in the matching key value. Query response item text attributes, including patient and physician names, that include non-ASCII characters will be displayed as described in Section 2.13.

15.2.2 Patient Level

This section defines the keys at the Patient Level of the Patient Root Query/Retrieve Information Models that are supported by this implementation.

TABLE 15-3
PATIENT LEVEL ATTRIBUTES FOR THE PATIENT ROOT
QUERY/RETRIEVE INFORMATION MODEL

Attribute Name	Tag	Type	SCU Use
Patient's Name	(0010,0010)	R*	Wildcard matching is requested automatically.
Patient ID	(0010,0020)	U*	Single value matching is supported from the 'Image > Retrieve' screen.

Note: * in the *Type* column indicates that this information is displayed on screen, if available

15.2.3 Study Level – Patient Root

This section defines the keys at the Study Level of the Patient Root Query/Retrieve Information Models that are supported by this implementation.

TABLE 15-4
STUDY LEVEL ATTRIBUTES FOR THE PATIENT ROOT
QUERY/RETRIEVE INFORMATION MODEL

Attribute Name	Tag	Type	SCU Use
Study Date	(0008,0020)	R*	Range matching is performed depending on the Study Date dropdown selection.
Study Time	(0008,0030)	R*	Always set to ""
Accession Number	(0008,0050)	R*	Always set to ""
Study ID	(0020,0010)	R*	Always set to ""
Study Instance UID	(0020,000D)	U	Always set to "" unless the MWL Studies button is used from a Referenced Study in the MWL.
Modalities in Study	(0008,0061)	O	Always set to ""
Study Description	(0008,1030)	O*	Always set to ""
Performing Physician's Name	(0008,1050)	O*	Always set to ""
Patient's Birthdate	(0010,0030)	O*	Always set to ""
Patient's Sex	(0010,0040)	O	Always set to ""
Number of Study related Instances	(0020,1208)	O	Always set to ""

Note: * in the *Type* column indicates that this information is displayed on screen, if available

15.2.4 Study Level – Study Root

This section defines the keys at the Study Level of the Study Root Query/Retrieve Information Model that are supported by this implementation.

TABLE 15-5
STUDY LEVEL ATTRIBUTES FOR THE STUDY ROOT
QUERY/RETRIEVE INFORMATION MODEL

Attribute Name	Tag	Type	SCU Use
Study Date	(0008,0020)	R*	Range matching is performed depending on the Study Date dropdown selection.
Study Time	(0008,0030)	R*	Always set to ""
Accession Number	(0008,0050)	R*	Always set to ""
Study ID	(0020,0010)	R*	Always set to ""
Patient's Name	(0010,0010)	R*	Wildcard matching is requested automatically.
Patient ID	(0010,0020)	R*	Single value matching is supported from the 'Image > Retrieve' screen.
Patient's Sex	(0010,0040)	O	Always set to ""
Study Instance UID	(0020,000D)	U	Always set to ""
Modalities in Study	(0008,0061)	O	Always set to ""
Study Description	(0008,1030)	O*	Always set to ""
Performing Physician's Name	(0008,1050)	O*	Always set to ""
Number of Study related Instances	(0020,1208)	O	Always set to ""
Patient's Birthdate	(0010,0030)	O*	Always set to ""

Note: * in the *Type* column indicates that this information is displayed on screen, if available

15.2.5 Series Level

This section defines the keys at the Series Level of the Patient Root and Study Root Query/Retrieve Information Models that are supported by this implementation.

TABLE 15-6
SERIES LEVEL ATTRIBUTES FOR THE
QUERY/RETRIEVE INFORMATION MODEL

Attribute Name	Tag	Type	SCU Use
Modality	(0008,0060)	R*	Always set to ""
Series Number	(0020,0011)	R	Always set to ""
Series Instance UID	(0020,000E)	U	Always set to ""
Number of Series Related Instances	(0020,1209)	O*	Always set to "". Number may be used to display the instance count to the user in the progress bar.

Note: * in the *Type* column indicates that this information is displayed on screen, if available

15.2.6 Image Level

The Elite Workstation does not send an Image level query of the Patient Root or Study Root Query/Retrieve Information Models that are supported by this implementation.

15.3 PRIVATE DATA ATTRIBUTES

The Product does not support any Private Attributes in Query identifiers.