

# Innova™ IGS 5

## Pre-Installation Manual



5730939-1EN

3

© 2017 General Electric Company

All rights reserved.

# Language policy

## Direction 2128126 - Language Policy For Service Documentation

ПРЕДУПРЕЖ ДЕНИЕ (BG)	<p>Това упътване за работа е налично само на английски език.</p> <ul style="list-style-type: none"><li>Ако доставчикът на услугата на клиента изиска друг език, задължение на клиента е да осигури превод.</li><li>Не използвайте оборудването, преди да сте се консултирали и разбрали упътването за работа.</li><li>Неспазването на това предупреждение може да доведе до нараняване на доставчика на услугата, оператора или пациента в резултат на токов удар, механична или друга опасност.</li></ul>
警告 (ZH-CN)	<p>本维修手册仅提供英文版本。</p> <ul style="list-style-type: none"><li>如果客户的维修服务人员需要非英文版本，则客户需自行提供翻译服务。</li><li>未详细阅读和完全理解本维修手册之前，不得进行维修。</li><li>忽略本警告可能对维修服务人员、操作人员或患者造成电击、机械伤害或其他形式的伤害。</li></ul>
警告 (ZH-HK)	<p>本服務手冊僅提供英文版本。</p> <ul style="list-style-type: none"><li>倘若客戶的服務供應商需要英文以外之服務手冊，客戶有責任提供翻譯服務。</li><li>除非已參閱本服務手冊及明白其內容，否則切勿嘗試維修設備。</li><li>不遵從本警告或會令服務供應商、網絡供應商或病人受到觸電、機械性或其他形式的危險。</li></ul>
警告 (ZH-TW)	<p>本維修手冊僅有英文版。</p> <ul style="list-style-type: none"><li>若客戶的維修廠商需要英文版以外的語言，應由客戶自行提供翻譯服務。</li><li>請勿試圖維修本設備，除非您已查閱並瞭解本維修手冊。</li><li>若未留意本警告，可能導致維修廠商、操作員或病患因觸電、機械或其他危險而受傷。</li></ul>
UPOZOR- ENJE (HR)	<p>Ovaj servisni priručnik dostupan je na engleskom jeziku.</p> <ul style="list-style-type: none"><li>Ako davatelj usluge klijenta treba neki drugi jezik, klijent je dužan osigurati prijevod.</li><li>Ne pokušavajte servisirati opremu ako niste u potpunosti pročitali i razumjeli ovaj servisni priručnik.</li><li>Zanemarite li ovo upozorenje, može doći do ozljede davatelja usluge, operatera ili pacijenta uslijed strujnog udara, mehaničkih ili drugih rizika.</li></ul>
VÝSTRAHA (CS)	<p>Tento provozní návod existuje pouze v anglickém jazyce.</p> <ul style="list-style-type: none"><li>V případě, že externí služba zákazníkům potřebuje návod v jiném jazyce, je zajištění překladu do odpovídajícího jazyka úkolem zákazníka.</li><li>Nesnažte se o údržbu tohoto zařízení, aniž byste si přečetli tento provozní návod a pochopili jeho obsah.</li><li>V případě nedodržování této výstrahy může dojít k poranění pracovníka prodejního servisu, obslužného personálu nebo pacientů vlivem elektrického proudu, respektive vlivem mechanických či jiných rizik.</li></ul>

ADVARSEL (DA)	<p>Denne servicemanual findes kun på engelsk.</p> <ul style="list-style-type: none"> <li>• Hvis en kundes tekniker har brug for et andet sprog end engelsk, er det kundens ansvar at sørge for oversættelse.</li> <li>• Forsøg ikke at servicere udstyret uden at læse og forstå denne servicemanual.</li> <li>• Manglende overholdelse af denne advarsel kan medføre skade på grund af elektrisk stød, mekanisk eller anden fare for teknikeren, operatøren eller patienten.</li> </ul>
WAAR-SCHUWING (NL)	<p>Deze onderhoudshandleiding is enkel in het Engels verkrijgbaar.</p> <ul style="list-style-type: none"> <li>• Als het onderhoudspersoneel een andere taal vereist, dan is de klant verantwoordelijk voor de vertaling ervan.</li> <li>• Probeer de apparatuur niet te onderhouden alvorens deze onderhoudshandleiding werd geraadpleegd en begrepen is.</li> <li>• Indien deze waarschuwing niet wordt opgevolgd, zou het onderhoudspersoneel, de operator of een patiënt gewond kunnen raken als gevolg van een elektrische schok, mechanische of andere gevaren.</li> </ul>
WARNING (EN)	<p>This service manual is available in English only.</p> <ul style="list-style-type: none"> <li>• If a customer's service provider requires a language other than English, it is the customer's responsibility to provide translation services.</li> <li>• Do not attempt to service the equipment unless this service manual has been consulted and is understood.</li> <li>• Failure to heed this warning may result in injury to the service provider, operator or patient from electric shock, mechanical or other hazards.</li> </ul>
HOIATUS (ET)	<p>See teenindusjuhend on saadaval ainult inglise keeles.</p> <ul style="list-style-type: none"> <li>• Kui klienditeeninduse osutaja nõuab juhendit inglise keelest erinevas keeles, vastutab klient tõlketeenuse osutamise eest.</li> <li>• Ärge üritage seadmeid teenindada enne eelnevalt käesoleva teenindusjuhendiga tutvumist ja sellest aru saamist.</li> <li>• Käesoleva hoiatuse eiramine võib põhjustada teenuseosutaja, operaatori või patsiendi vigastamist elektrilöögi, mehaanilise või muu ohu tagajärjel.</li> </ul>
VAROITUS (FI)	<p>Tämä huolto-ohje on saatavilla vain englanniksi.</p> <ul style="list-style-type: none"> <li>• Jos asiakkaan huoltohenkilöstö vaatii muuta kuin englanninkielistä materiaalia, tarvittavan käännöksen hankkiminen on asiakkaan vastuulla.</li> <li>• Älä yritä korjata laitteistoa ennen kuin olet varmasti lukenut ja ymmärtänyt tämän huolto-ohjeen.</li> <li>• Mikäli tätä varoitusta ei noudateta, seurauksena voi olla huoltohenkilöstön, laitteiston käyttäjän tai potilaan vahingoittuminen sähköiskun, mekaanisen vian tai muun vaaratilanteen vuoksi.</li> </ul>

<p>ATTENTION (FR)</p>	<p>Ce manuel d'installation et de maintenance est disponible uniquement en anglais.</p> <ul style="list-style-type: none"> <li>• Si le technicien d'un client a besoin de ce manuel dans une langue autre que l'anglais, il incombe au client de le faire traduire.</li> <li>• Ne pas tenter d'intervenir sur les équipements tant que ce manuel d'installation et de maintenance n'a pas été consulté et compris.</li> <li>• Le non-respect de cet avertissement peut entraîner chez le technicien, l'opérateur ou le patient des blessures dues à des dangers électriques, mécaniques ou autres.</li> </ul>
<p>WARNUNG (DE)</p>	<p>Diese Serviceanleitung existiert nur in englischer Sprache.</p> <ul style="list-style-type: none"> <li>• Falls ein fremder Kundendienst eine andere Sprache benötigt, ist es Aufgabe des Kunden für eine entsprechende Übersetzung zu sorgen.</li> <li>• Versuchen Sie nicht diese Anlage zu warten, ohne diese Serviceanleitung gelesen und verstanden zu haben.</li> <li>• Wird diese Warnung nicht beachtet, so kann es zu Verletzungen des Kundendiensttechnikers, des Bedieners oder des Patienten durch Stromschläge, mechanische oder sonstige Gefahren kommen.</li> </ul>
<p>ΠΡΟΕΙΔΟΠΟΙΗΣΗ (EL)</p>	<p>Το παρόν εγχειρίδιο σέρβις διατίθεται στα αγγλικά μόνο.</p> <ul style="list-style-type: none"> <li>• Εάν το άτομο παροχής σέρβις ενός πελάτη απαιτεί το παρόν εγχειρίδιο σε γλώσσα εκτός των αγγλικών, αποτελεί ευθύνη του πελάτη να παρέχει υπηρεσίες μετάφρασης.</li> <li>• Μηνεπιχειρήσετε την εκτέλεση εργασιών σέρβις στον εξοπλισμό εκτός εάν έχετε συμβουλευτεί και έχετε κατανοήσει το παρόν εγχειρίδιο σέρβις.</li> <li>• Εάν δεν λάβετε υπόψη την προειδοποίηση αυτή, ενδέχεται να προκληθεί τραυματισμός στο άτομο παροχής σέρβις, στο χειριστή ή στον ασθενή από ηλεκτροπληξία, μηχανικούς ή άλλους κινδύνους.</li> </ul>
<p>FIGYELMEZTETÉS (HU)</p>	<p>Ezen karbantartási kézikönyv kizárólag angol nyelven érhető el.</p> <ul style="list-style-type: none"> <li>• Ha a vevő szolgáltatója angoltól eltérő nyelvre tart igényt, akkor a vevő felelőssége a fordítás elkészítése.</li> <li>• Ne próbálja elkezdni használni a berendezést, amíg a karbantartási kézikönyvben leírtakat nem értelmezték.</li> <li>• Ezen figyelmeztetés figyelmen kívül hagyása a szolgáltató, működtető vagy a beteg áramütés, mechanikai vagy egyéb veszélyhelyzet miatti sérülését eredményezheti.</li> </ul>
<p>AÐVÖRUN (IS)</p>	<p>Þessi þjónustuhandbók er aðeins fáanleg á ensku.</p> <ul style="list-style-type: none"> <li>• Ef að þjónustuveitandi viðskiptamanns þarfnast annars tungumáls en ensku, er það skylda viðskiptamanns að skaffa tungumálþjónustu.</li> <li>• Reynið ekki að afgreiða tækið nema að þessi þjónustuhandbók hefur verið skoðuð og skilin.</li> <li>• Brot á sinna þessari aðvörun getur leitt til meiðsla á þjónustuveitanda, stjórnanda eða sjúklings frá raflosti, vélrænu eða öðrum áhættum.</li> </ul>

AVVERTENZA (IT)	<p>Il presente manuale di manutenzione è disponibile soltanto in lingua inglese.</p> <ul style="list-style-type: none"> <li>• Se un addetto alla manutenzione richiede il manuale in una lingua diversa, il cliente è tenuto a provvedere direttamente alla traduzione.</li> <li>• Procedere alla manutenzione dell'apparecchiatura solo dopo aver consultato il presente manuale ed averne compreso il contenuto.</li> <li>• Il mancato rispetto della presente avvertenza potrebbe causare lesioni all'addetto alla manutenzione, all'operatore o ai pazienti provocate da scosse elettriche, urti meccanici o altri rischi.</li> </ul>
警告 (JA)	<p>このサービスマニュアルには英語版しかありません。</p> <ul style="list-style-type: none"> <li>• サービスを担当される業者が英語以外の言語を要求される場合、翻訳作業はその業者の責任で行うものとさせていただきます。</li> <li>• このサービスマニュアルを熟読し理解せずに、装置のサービスを行わないでください。</li> <li>• この警告に従わない場合、サービスを担当される方、操作員あるいは患者さんが、感電や機械的又はその他の危険により負傷する可能性があります。</li> </ul>
경고 (KO)	<p>본 서비스 매뉴얼은 영어로만 이용하실 수 있습니다.</p> <ul style="list-style-type: none"> <li>• 고객의 서비스 제공자가 영어 이외의 언어를 요구할 경우, 번역 서비스를 제공하는 것은 고객의 책임입니다.</li> <li>• 본 서비스 매뉴얼을 참조하여 숙지하지 않은 이상 해당 장비를 수리하려고 시도하지 마십시오.</li> <li>• 본 경고 사항에 유의하지 않으면 전기 쇼크, 기계적 위험, 또는 기타 위험으로 인해 서비스 제공자, 사용자 또는 환자에게 부상을 입힐 수 있습니다.</li> </ul>
BRĪDINĀ- JUMS (LV)	<p>Šī apkopes rokasgrāmata ir pieejama tikai angļu valodā.</p> <ul style="list-style-type: none"> <li>• Ja klienta apkopes sniedzējam nepieciešama informācija citā valodā, klienta pienākums ir nodrošināt tulkojumu.</li> <li>• Neveiciet aprikojuma apkopi bez apkopes rokasgrāmatas izlasīšanas un saprašanas.</li> <li>• Šī brīdinājuma neievērošanas rezultātā var rasties elektriskās strāvas triecienu, mehānisku vai citu faktoru izraisītu traumu risks apkopes sniedzējam, operatoram vai pacientam.</li> </ul>
ĮSPĖJIMAS (LT)	<p>Šis eksploataavimo vadovas yra tik anglų kalba.</p> <ul style="list-style-type: none"> <li>• Jei kliento paslaugų tiekėjas reikalauja vadovo kita kalba – ne anglų, suteikti vertimo paslaugas privalo klientas.</li> <li>• Nemėginkite atlikti įrangos techninės priežiūros, jei neperskaitėte ar nesupratote šio eksploataavimo vadovo.</li> <li>• Jei nepaisysite šio įspėjimo, galimi paslaugų tiekėjo, operatoriaus ar paciento sužalojimai dėl elektros šoko, mechaninių ar kitų pavojų.</li> </ul>
ADVARSEL (NO)	<p>Denne servicehåndboken finnes bare på engelsk.</p> <ul style="list-style-type: none"> <li>• Hvis kundens serviceleverandør har bruk for et annet språk, er det kundens ansvar å sørge for oversettelse.</li> <li>• Ikke forsøk å reparere utstyret uten at denne servicehåndboken er lest og forstått.</li> <li>• Manglende hensyn til denne advarselen kan føre til at serviceleverandøren, operatøren eller pasienten skades på grunn av elektrisk støt, mekaniske eller andre farer.</li> </ul>

<p>OSTRZEŻENIE (PL)</p>	<p>Niniejszy podręcznik serwisowy dostępny jest jedynie w języku angielskim.</p> <ul style="list-style-type: none"> <li>• Jeśli serwisant klienta wymaga języka innego niż angielski, zapewnienie usługi tłumaczenia jest obowiązkiem klienta.</li> <li>• Nie próbować serwisować urządzenia bez zapoznania się z niniejszym podręcznikiem serwisowym i zrozumienia go.</li> <li>• Niezastosowanie się do tego ostrzeżenia może doprowadzić do obrażeń serwisanta, operatora lub pacjenta w wyniku porażenia prądem elektrycznym, zagrożenia mechanicznego bądź innego.</li> </ul>
<p>ATENÇÃO (PT-BR)</p>	<p>Este manual de assistência técnica encontra-se disponível unicamente em inglês.</p> <ul style="list-style-type: none"> <li>• Se outro serviço de assistência técnica solicitar a tradução deste manual, caberá ao cliente fornecer os serviços de tradução.</li> <li>• Não tente reparar o equipamento sem ter consultado e compreendido este manual de assistência técnica.</li> <li>• A não observância deste aviso pode ocasionar ferimentos no técnico, operador ou paciente decorrentes de choques elétricos, mecânicos ou outros.</li> </ul>
<p>ATENÇÃO (PT-PT)</p>	<p>Este manual de assistência técnica só se encontra disponível em inglês.</p> <ul style="list-style-type: none"> <li>• Se qualquer outro serviço de assistência técnica solicitar este manual noutra idioma, é da responsabilidade do cliente fornecer os serviços de tradução.</li> <li>• Não tente reparar o equipamento sem ter consultado e compreendido este manual de assistência técnica.</li> <li>• O não cumprimento deste aviso pode colocar em perigo a segurança do técnico, do operador ou do paciente devido a choques eléctricos, mecânicos ou outros.</li> </ul>
<p>ATENȚIE (RO)</p>	<p>Acest manual de service este disponibil doar în limba engleză.</p> <ul style="list-style-type: none"> <li>• Dacă un furnizor de servicii pentru clienți necesită o altă limbă decât cea engleză, este de datoria clientului să furnizeze o traducere.</li> <li>• Nu încercați să reparați echipamentul decât ulterior consultării și înțelegerii acestui manual de service.</li> <li>• Ignorarea acestui avertisment ar putea duce la rănirea depanatorului, operatorului sau pacientului în urma pericolelor de electrocutare, mecanice sau de altă natură.</li> </ul>
<p>ОСТОРОЖНО! (RU)</p>	<p>Данное руководство по техническому обслуживанию представлено только на английском языке.</p> <ul style="list-style-type: none"> <li>• Если сервисному персоналу клиента необходимо руководство не на английском, а на каком-то другом языке, клиенту следует самостоятельно обеспечить перевод.</li> <li>• Перед техническим обслуживанием оборудования обязательно обратитесь к данному руководству и поймите изложенные в нем сведения.</li> <li>• Несоблюдение требований данного предупреждения может привести к тому, что специалист по техобслуживанию, оператор или пациент получит удар электрическим током, механическую травму или другое повреждение.</li> </ul>

UPOZOR- ENJE (SR)	<p>Ovo servisno uputstvo je dostupno samo na engleskom jeziku.</p> <ul style="list-style-type: none"> <li>• Ako klijentov serviser zahteva neki drugi jezik, klijent je dužan da obezbedi prevodilačke usluge.</li> <li>• Ne pokušavajte da opravite uređaj ako niste pročitali i razumeli ovo servisno uputstvo.</li> <li>• Zanemarivanje ovog upozorenja može dovesti do povređivanja serviser, rukovaoca ili pacijenta usled strujnog udara ili mehaničkih i drugih opasnosti.</li> </ul>
UPOZORNE- NIE (SK)	<p>Tento návod na obsluhu je k dispozícii len v angličtine.</p> <ul style="list-style-type: none"> <li>• Ak zákazníkovi poskytovateľ služieb vyžaduje iný jazyk ako angličtinu, poskytnutie prekladateľských služieb je zodpovednosťou zákazníka.</li> <li>• Nepokúšajte sa o obsluhu zariadenia, kým si neprečítate návod na obsluhu a neporozumiete mu.</li> <li>• Zanedbanie tohto upozornenia môže spôsobiť zranenie poskytovateľa služieb, obsluhujúcej osoby alebo pacienta elektrickým prúdom, mechanické alebo iné ohrozenie.</li> </ul>
ATENCIÓN (ES)	<p>Este manual de servicio sólo existe en inglés.</p> <ul style="list-style-type: none"> <li>• Si el encargado de mantenimiento de un cliente necesita un idioma que no sea el inglés, el cliente deberá encargarse de la traducción del manual.</li> <li>• No se deberá dar servicio técnico al equipo, sin haber consultado y comprendido este manual de servicio.</li> <li>• La no observancia del presente aviso puede dar lugar a que el proveedor de servicios, el operador o el paciente sufran lesiones provocadas por causas eléctricas, mecánicas o de otra naturaleza.</li> </ul>
VARNING (SV)	<p>Den här servicehandboken finns bara tillgänglig på engelska.</p> <ul style="list-style-type: none"> <li>• Om en kunds servicetekniker har behov av ett annat språk än engelska, ansvarar kunden för att tillhandahålla översättningstjänster.</li> <li>• Försök inte utföra service på utrustningen om du inte har läst och förstår den här servicehandboken.</li> <li>• Om du inte tar hänsyn till den här varningen kan det resultera i skador på serviceteknikern, operatören eller patienten till följd av elektriska stötar, mekaniska faror eller andra faror.</li> </ul>
OPOZORILO (SL)	<p>Ta servisni priročnik je na voljo samo v angleškem jeziku.</p> <ul style="list-style-type: none"> <li>• Če ponudnik storitve stranke potrebuje priročnik v drugem jeziku, mora stranka zagotoviti prevod.</li> <li>• Ne poskušajte servisirati opreme, če tega priročnika niste v celoti prebrali in razumeli.</li> <li>• Če tega opozorila ne upoštevate, se lahko zaradi električnega udara, mehanskih ali drugih nevarnosti poškoduje ponudnik storitev, operater ali bolnik.</li> </ul>
DİKKAT (TR)	<p>Bu servis k&amp;inodot;lavuzunun sadece ingilizcesi mevcuttur.</p> <ul style="list-style-type: none"> <li>• Eğer müşteri teknisyeni bu k&amp;inodot;lavuzu ingilizce d&amp;inodot;ş&amp;inodot;nda bir başka lisan-dan talep ederse, bunu tercüme ettirmek müşteriye düşer.</li> <li>• Servis k&amp;inodot;lavuzunu okuyup anlamadan ekipmanlara müdahale etmeyiniz.</li> <li>• Bu uyar&amp;inodot;ya uyulmamas&amp;inodot;, elektrik, mekanik veya diğer tehlikelerden dolay&amp;inodot; teknisyen, operatör veya hastan&amp;inodot;n yaralanmas&amp;inodot;na yol açabilir.</li> </ul>

# Revision History

Part/Rev	Date	Reason for Change	Pages
5730939-1EN rev 1	April 10, 2017	Initial release of direction 5730939-1EN	180
5730939-1EN rev 2	September 19, 2017	Release after HII review	188
5730939-1EN rev 3	November 6, 2017	Post FDR3 release	190

Page intentionally left blank

# Contents

<b>Chapter 1 General Requirements</b>	<b>1</b>
1.1 Objectives & Overview	1
1.1.1 Object and Scope of this manual	1
1.1.2 Pre-Installation Process	1
1.2 Customer Responsibilities	2
1.2.1 Responsibilities of the Purchaser/Customer	2
1.2.2 Equipment Classifications	3
1.2.3 Pre-Installation Checklist	5
1.3 Delivery Requirements	5
1.3.1 Shipping Information	5
1.3.2 Tools and Test Equipment	17
1.3.3 Door Size Requirements	18
1.3.4 Route Survey	19
1.3.5 European Process Order Select	20
1.4 Product Storage and Handling Requirement.	20
<b>Chapter 2 Equipment Requirements</b>	<b>25</b>
2.1 System Components	25
2.1.1 Presentation of the 3 Rooms.	25
2.1.2 Description of Innova System	26
2.1.3 Dimension Drawings	42
2.2 Room Layouts	69
2.2.1 Room Dimension Requirements.	69
2.2.2 Room Layout Drawings	71
2.2.3 Room Layout Considerations	84
2.3 Room Structural Requirements	86
2.3.1 General Policy	86
2.3.2 Floor Requirements	88
2.3.3 Mounting Requirements	94
2.3.4 Ceiling Requirements	103
2.3.5 Wall Requirements.	108
2.4 Mounting Data, Including Seismic	109
<b>Chapter 3 Special Construction Requirements</b>	<b>123</b>
3.1 Radiation Protection	123
3.2 EMI Consideration	123
<b>Chapter 4 Environmental Requirements</b>	<b>133</b>
4.1 Humidity, Temperature and Altitude	133
4.2 Heat Output	134

4.3 Acoustic Specifications . . . . .	135
4.4 Room Light . . . . .	135
<b>Chapter 5 Electrical Requirements . . . . .</b>	<b>137</b>
5.1 System Electrical Ratings. . . . .	137
5.2 Power Distribution Schematics . . . . .	138
5.3 Mains Disconnect Panel . . . . .	141
5.4 External Interfaces. . . . .	152
5.5 System Cable Information . . . . .	156
5.5.1 Physical Runs . . . . .	156
5.5.2 MIS (Master Interconnect System) . . . . .	172
5.5.3 Cable Channeling . . . . .	173
<b>Chapter 6 Communication Requirements . . . . .</b>	<b>177</b>
6.1 Network Requirements . . . . .	177
6.2 Privacy and Security Configuration. . . . .	177

# Chapter 1 General Requirements

## 1.1 Objectives & Overview

### 1.1.1 Object and Scope of this manual

#### 1.1.1.1 Object and Scope

This document is intended as a guide and information resource to properly plan and prepare a site for the installation of an Innova system (This includes the Innova IGS 520, Innova IGS 530 and Innova IGS 540).

In addition, this document provides references to the pre-installation documents of the various product included with an Innova System.

These documents are intended to assist the Installation Specialist and the Site Planner in properly preparing a site for the installation of this system.

It provides pre-installation data, such as site preparation prior to the delivery of the Innova System, environmental and electrical requirements and some additional planning aids.



MAKE SURE THE ROOM PREPARATION COMPLIES WITH LOCAL REGULATIONS  
AS THE PIM IS NOT INTENDED TO REFLECT ALL OF THEM

#### 1.1.1.2 Quebec

GE Healthcare is "GE Santé" in Province of Quebec - Canada.

### 1.1.2 Pre-Installation Process

Complete the checklists in ROOM LAYOUTS, ELECTRICAL REQUIREMENTS, and GENERAL REQUIREMENTS of this manual. They represent an important part of the pre-installation process. The checklists summarize the required preparations and allow to verify the proper completion of the pre-installation procedures.

You will find hereafter a chart of the information flow in the pre-installation process.

Figure 1

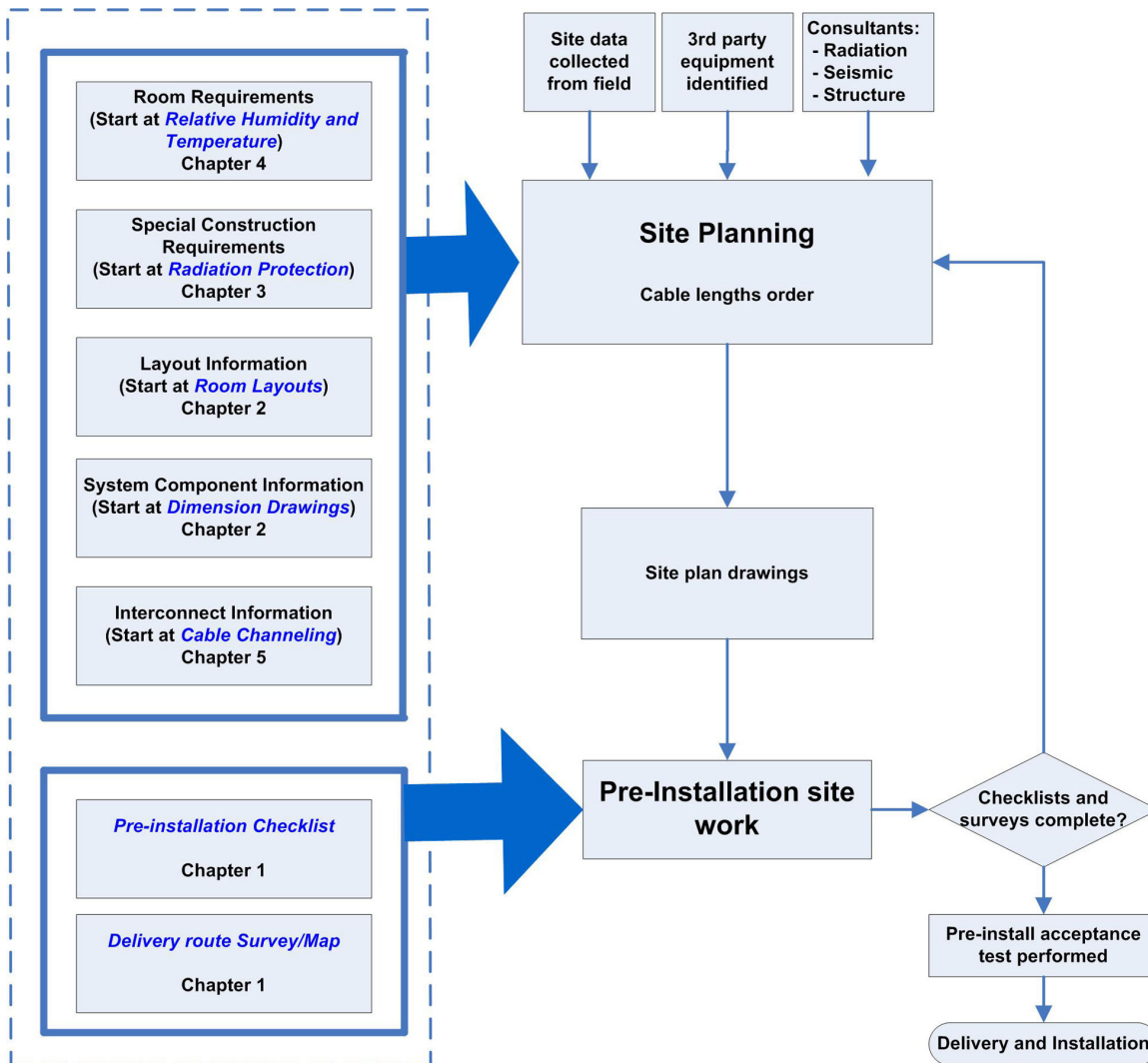

## 1.2 Customer Responsibilities

### 1.2.1 Responsibilities of the Purchaser/Customer

To ensure that the installation of an Innova System meets the purchaser or customer expectations, it is important to determine who will take responsibility for the various items during the system installation process. To help you in determining these responsibilities, review the following checklists with the customer and assign responsibilities as appropriate:

- Tool and Test Equipment (1.3.2 Tools and Test Equipment on page 17)
- Pre-Installation Checklist (1.2.3 Pre-Installation Checklist on page 5)

Contract Changes:

Be sure to inform the customer that the cost of any alteration or modification not specified in the sales contract are liable to the customer.

The following equipment must be installed by the Hospital's Contractors, per room drawings:

1. GE-supplied equipment:

- Gantry & Table baseplate with holes drilled (Per supplied template)
- **(For Suspension with rails)** Monitor suspension stationary rails
- **(For LDM Suspension with fixed point Dual Arm)** Substructure for Dual Arm suspension (S18391MX)

**NOTE**

Means necessary to anchor of the Substructure for Dual Arm suspension (anchors, bolts, screws, etc.) are not delivered with the kit and should be provided and designed under customer responsibility.

- Gantry baseplate grout
- Gantry baseplate
- Omega/Innova<sup>IQ</sup> table and Innova<sup>IQ</sup> OR table common baseplate (if applicable)

2. Customer supplied equipment:



- MDP (Mains Disconnect Panel)
- Power cables to PDU
- EPO cable MDP-PDU
- Ground cable MDP-PDU
- **(For LDM Suspension with fixed point Dual Arm)** Means necessary to anchor of the Substructure for Dual Arm suspension (anchors, bolts, screws, etc.)

**NOTE**

In case of Innova<sup>IQ</sup> table and Innova<sup>IQ</sup> OR table upgrade, it is critical to have the table baseplate flushed in the concrete.

## 1.2.2 Equipment Classifications

The following equipment classifications are applicable to the product:

Classification category	Equipment classification
Protection against electric shock	<p>Class I</p>  <p>TO AVOID THE RISK OF ELECTRIC SHOCK, THIS EQUIPMENT MUST ONLY BE CONNECTED TO A SUPPLY MAINS WITH PROTECTIVE EARTH.</p>
Degree of protection against electric shock	<p>Type B applied parts</p>  <p>Applied parts complying with the specified requirements of the IEC 60601-1 standard to provide protection against electric shock, particularly regarding allowable patient leakage current and patient auxiliary current include:</p> <ul style="list-style-type: none"> <li>• Mattress</li> <li>• Table accessories: shoulder rest, foot rest, table head extender, Removable rails (sleeve), Head widener with pad/cushion, Width extender with pad/cushion, armboard with thick pad/cushion, rail extender and patient restraint strap with cushion.</li> </ul>
Degree of protection against harmful ingress of water	<p>Ordinary equipment (enclosed equipment without protection against ingress of water); except footswitch which is a watertight device (protected against the effects of submersion, IPX7/IPX8)</p> <p>Systems with Innova<sup>IQ</sup> OR Table: Table, TSSC, Smart Box, Table Panning Device and Innova Central touch screen are watertight devices protected against the effects of splashing (IPX4). Footswitch is a watertight device protected against the effect of submersion (IPX8).</p>
Method(s) of sterilization or disinfection recommended by the manufacturer	<ul style="list-style-type: none"> <li>• Sterilization: not applicable</li> <li>• Disinfection: refer to Operator Manual (Chapter Safety and Regulatory, section Disinfection), Recommended disinfecting agents. The system does not fulfill the requirements for AP/APG classification (IEC 60601-1).</li> </ul>
Degree of safety of application in the presence of a flammable anesthetic mixture with air or with oxygen or nitrous oxide	<p>Equipment not suitable for use in the presence of a flammable anesthetic mixture with air or with oxygen or nitrous oxide</p>
Mode of operation	<p>Continuous operation with intermittent loading</p>

**NOTICE**

The system can only be installed in an anesthetizing location if that location is classified as Other Than Hazardous as per NFPA 70 clause 517.60

**NOTICE**

The product is not classified as AP, APG (Equipment not suitable for use in the presence of a flammable anaesthetic mixture with air or with oxygen or nitrous oxide).

## 1.2.3 Pre-Installation Checklist

Refer to the document *Global Site Readiness Checklist DI - DOC1809666* for standard HPM requirements on Room preparation for Vascular Systems installation.

See also the specific preparation requirements for IGS Systems installation given in sections 3, 4 and 5 of the Tab "Installation Prerequisites" in document *IGS System Installation Prerequisites - DOC2024755*.

**NOTE**

DOC1809666 and DOC2024755 are available from MyWorkshop.

## 1.3 Delivery Requirements

### 1.3.1 Shipping Information

#### 1.3.1.1 Product Shipping Information

Refer to the table below. To obtain shipping information for components not specified in the table, refer to the appropriate component Pre-Installation Manual.

**Table 1**

PRODUCT OR COMPONENT	DIMENSIONS			WEIGHT kg (lbs)	METHOD OF SHIPMENT
	Height mm (in)	Width mm (in)	Depth mm (in)		
Gantry	2000 (79)	2790 (110)	1155 (45.5)	1060 (2,340)	Shipping Dolly. See <a href="#">Figure 2 on page 7</a>
	2300 (90.5)	2900 (114)	1380 (54.5)	1200 (2,645)	Air shipment. See <a href="#">Figure 3 on page 8</a>
C-FRT Cabinet	2200 (87)	1480 (59)	850 (34)	645 (1,421)	On pallet. See <a href="#">Figure 4 on page 9</a>
NPA PDU	2020 (80)	985 (39)	567 (22)	380 (838)	On pallet. See <a href="#">Figure 5 on page 10</a>

continued					
PRODUCT OR COMPONENT	DIMENSIONS			WEIGHT kg (lbs)	METHOD OF SHIPMENT
	Height mm (in)	Width mm (in)	Depth mm (in)		
Omega Table Base Assembly	1240 (49)	960 (38)	2140 (84.2)	585 (1,290)	On pallet. See <a href="#">Figure 6 on page 11</a>
Omega Table Top Assembly	220 (9)	3470 (137)	840 (33)	70 (155)	On pallet. See <a href="#">Figure 6 on page 11</a>
Innova <sup>IQ</sup> table and Innova <sup>IQ</sup> OR table Base Assembly and covers	1160 (45.7)	1000 (39.4)	2150 (84.6)	750 (1,653)	On pallet. See <a href="#">Figure 8 on page 13</a> and <a href="#">Figure 9 on page 14</a>
X-Ray tube housing	960 (37.7)	770 (30.3)	710 (28)	113 (250)	On pallet
Chiller 4100	1200 (47.2)	555 (21.8)	610 (24)	120 (264.5)	On pallet
Gantry Requisites	-	-	-	-	On pallet
Cables	-	-	-	-	On pallet
Monitor susp. bridge	640 (25.2)	980 (38.6)	3060 (120.5)	210 (445)	On pallet
Monitor susp. rails	380 (15)	300 (12)	5960 (235)	160 (355)	On pallet
Large Display monitor (Eizo and Barco)	1050 (41.3)	1500 (59)	800 (31.4)	95 (209)	On pallet, see <a href="#">Figure 10 on page 14</a>
LD suspension with rails	1100 (43.3)	1100 (43.3)	1850 (72.8)	390 (860)	On pallet
LD suspension with rails 36 m harness	230 (9)	800 (34.5)	800 (34.5)	62 (134)	On pallet
Substructure for Dual Arm suspension (for Mavig suspension with fixed point dual arm for Large Display Monitor)	330 (13)	1040 (41)	490 (19.3)	70 (154.3)	On pallet, see <a href="#">Figure 11 on page 15</a>
Mavig suspension with fixed point dual arm for Large Display Monitor	1860 (73.2)	2150 (84.6)	900 (35.4)	370 (815.7)	On pallet, see <a href="#">Figure 12 on page 16</a>
Fluoro UPS UL	2100 (82.7)	890 (35)	1000 (39.4)	561 (1,235)	On pallet
Fluoro UPS CE	1750 (68.9)	890 (35)	1000 (39.4)	585 (1,287)	On pallet

### 1.3.1.2 Detail Of Innova Shipping Information

#### 1.3.1.2.1 Gantry on Shipping Dolly

Figure 2 Gantry on Shipping Dolly

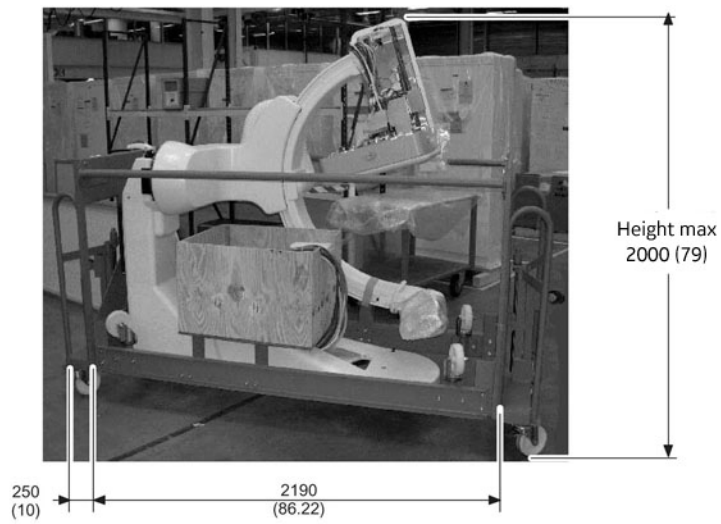

All dimensions are in mm (in inches)

≈ 300 mm  
(12) with caster

### 1.3.1.2.2 Gantry Air Shipment

Figure 3 Gantry Air Shipment

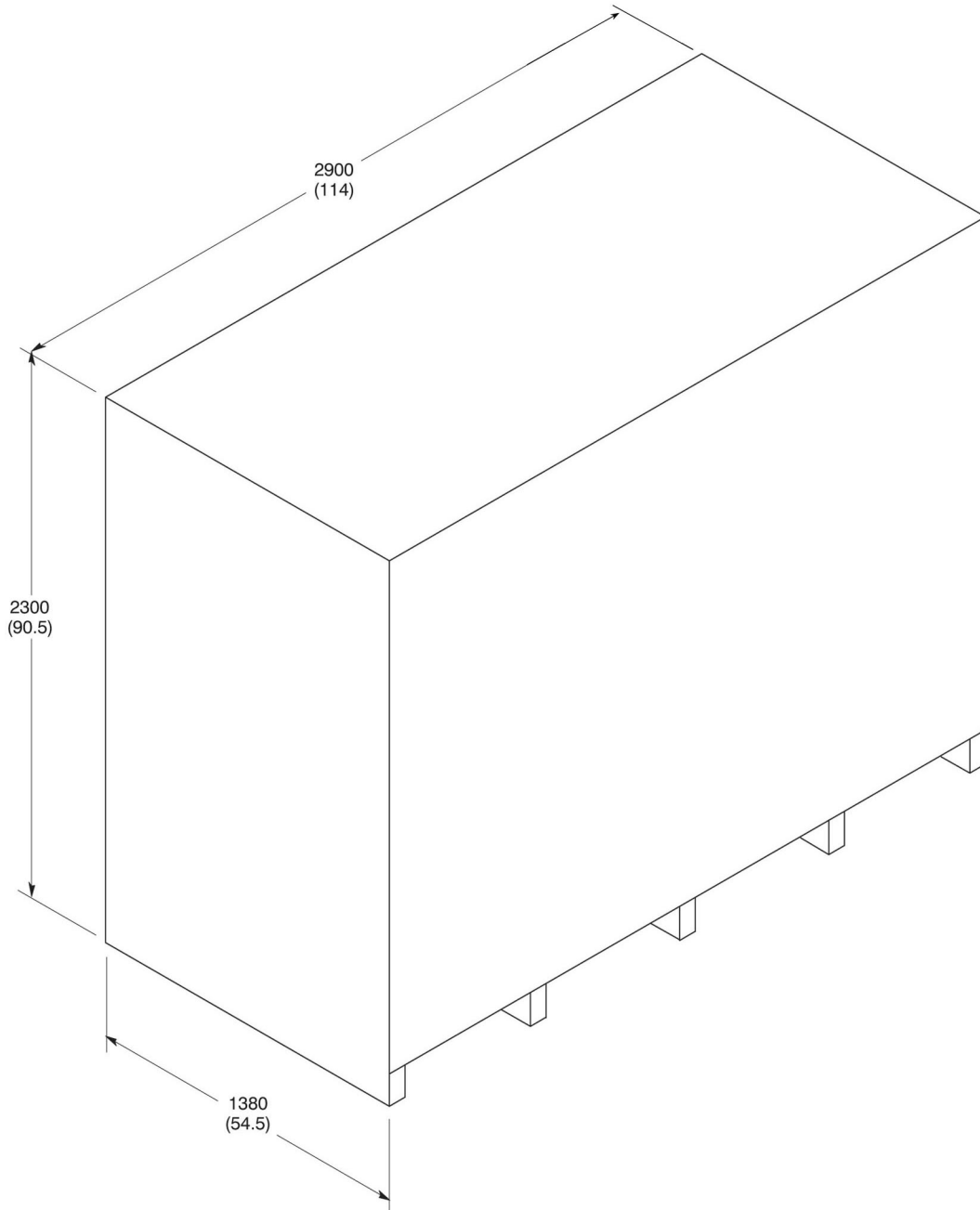

DIMENSIONS IN MM (INCHES)

NOT TO SCALE

### 1.3.1.2.3 C-FRT Cabinet Shipment

Figure 4 C-FRT Cabinet Shipment



**NOTE**

Pallet is delivered as part of C-FRT Cabinet packaging.

### 1.3.1.2.4 NPA PDU Shipment

Figure 5 NPA PDU Shipment



**NOTE**

Pallet is delivered as part of NPA PDU packaging.

### 1.3.1.2.5 Omega Table Shipment

Figure 6 Omega Table Shipment

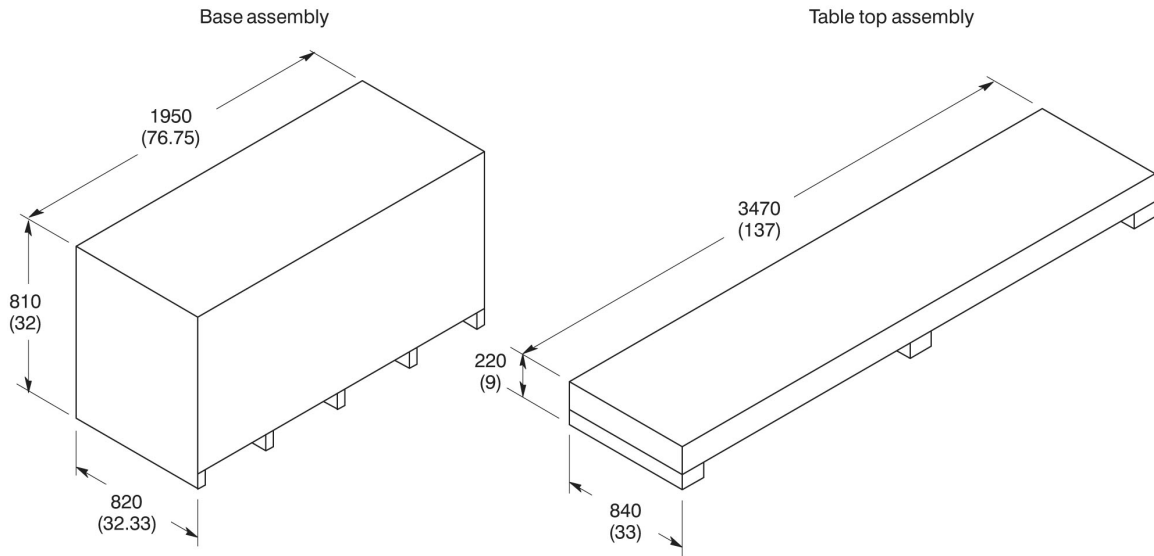

DIMENSIONS IN MM (INCHES)

**NOT TO SCALE**

### 1.3.1.2.6 Omega Table using Positioner Dollies

Figure 7 Omega Table and Positioner Dollies

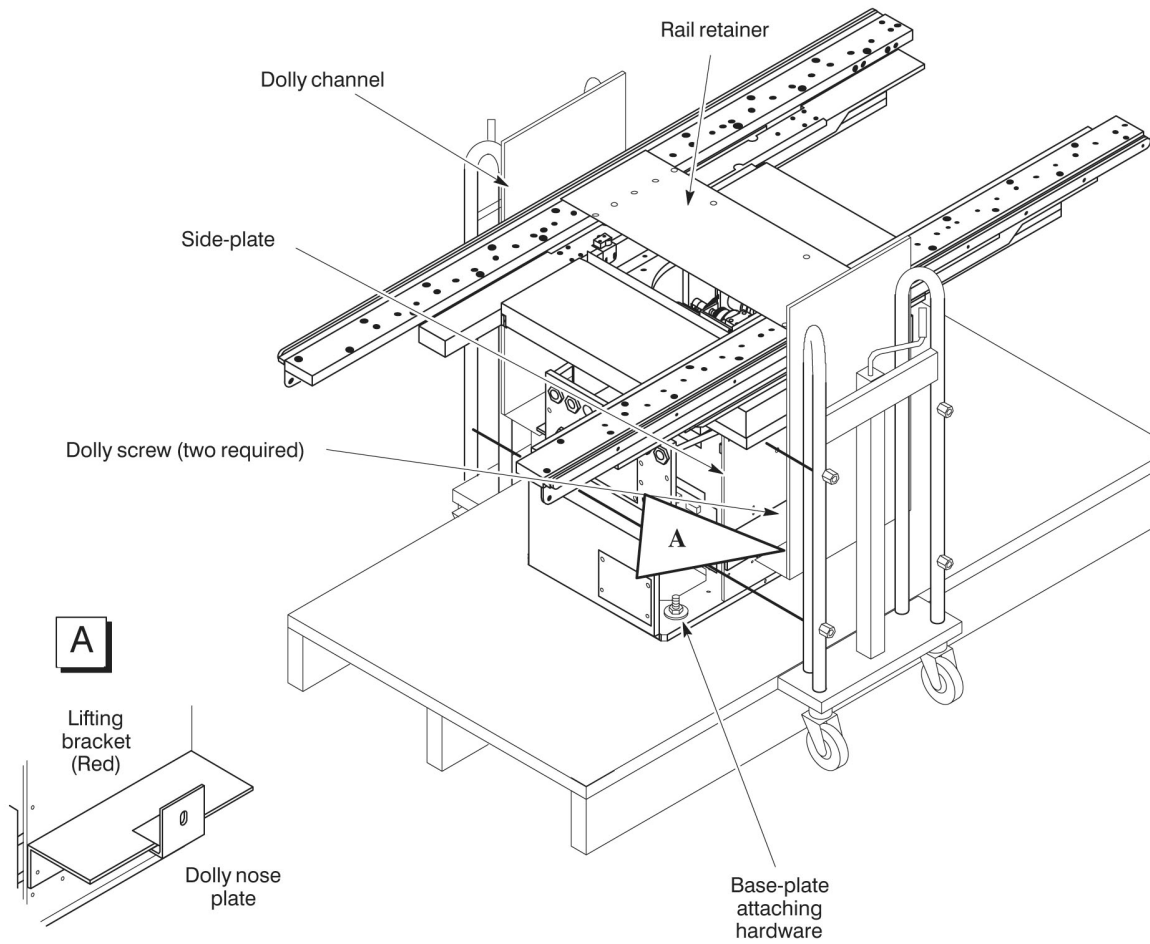

### 1.3.1.2.7 Innova<sup>IQ</sup> Table and Innova<sup>IQ</sup> OR Table Shipment

Figure 8 Innova<sup>IQ</sup> Table and nnova<sup>IQ</sup> OR Table Shipment

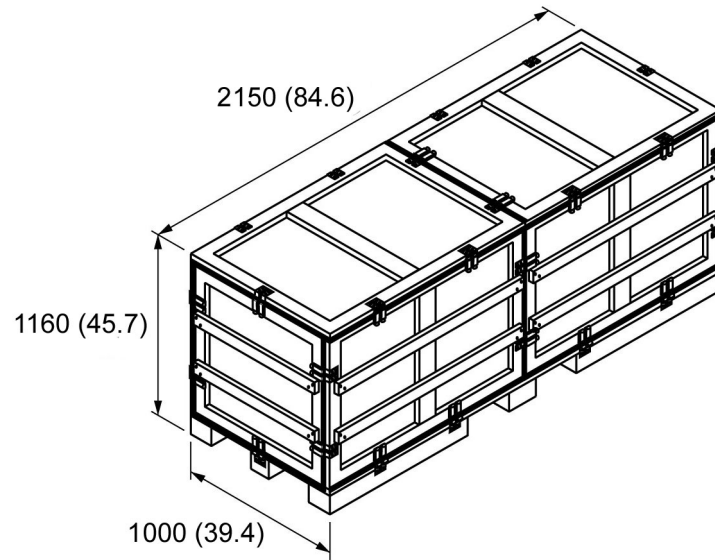

All dimensions are in mm (inches)

Figure 9 Covers Shipment

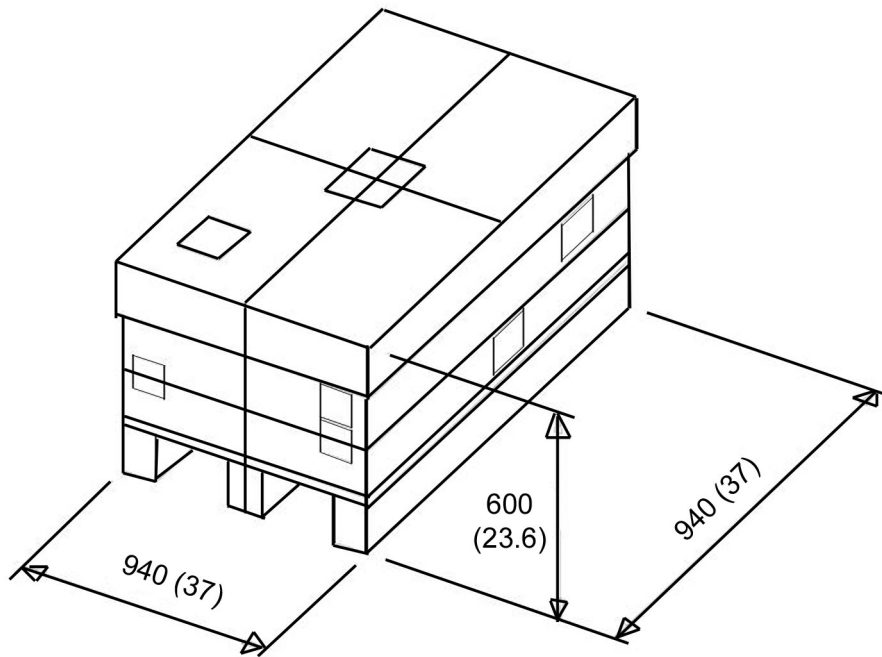

All dimensions are in mm (inches)

### 1.3.1.2.8 Large Display Monitor (Option)

Figure 10 Large Display Monitor Shipment



Dimensions in mm (in)

### 1.3.1.2.9 Large Display Monitor suspension with fixed point dual arm

#### 1.3.1.2.9.1 Substructure for Dual Arm suspension

Figure 11 Shipment of Substructure for Dual Arm suspension

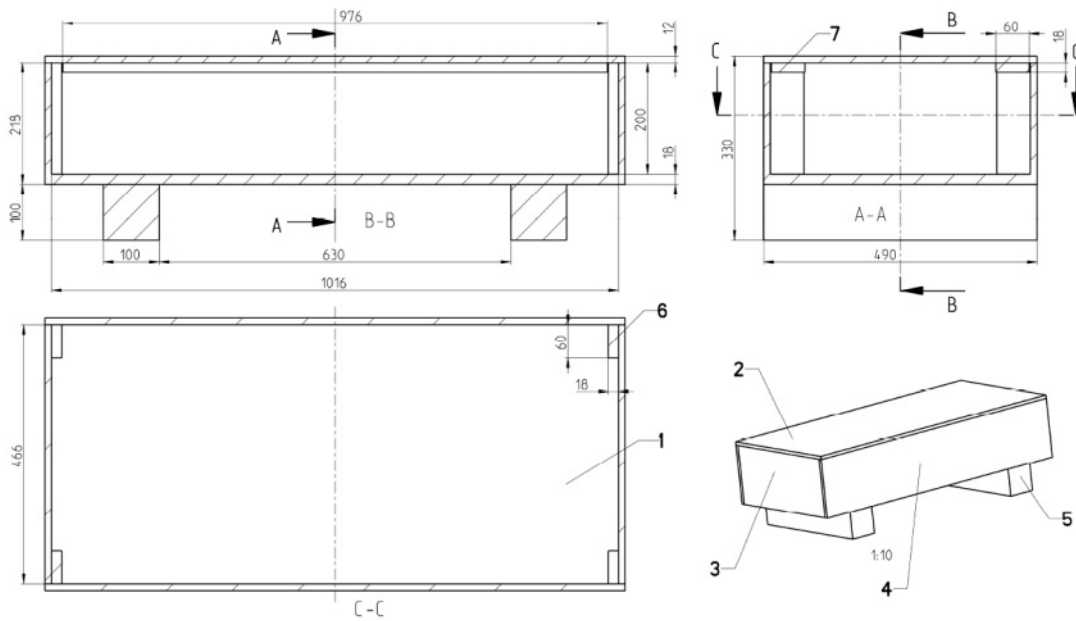

### 1.3.1.2.9.2 Mavig suspension with fixed point dual arm for Large Display Monitor

Figure 12 MAVIG suspension with fixed point dual arm Shipment

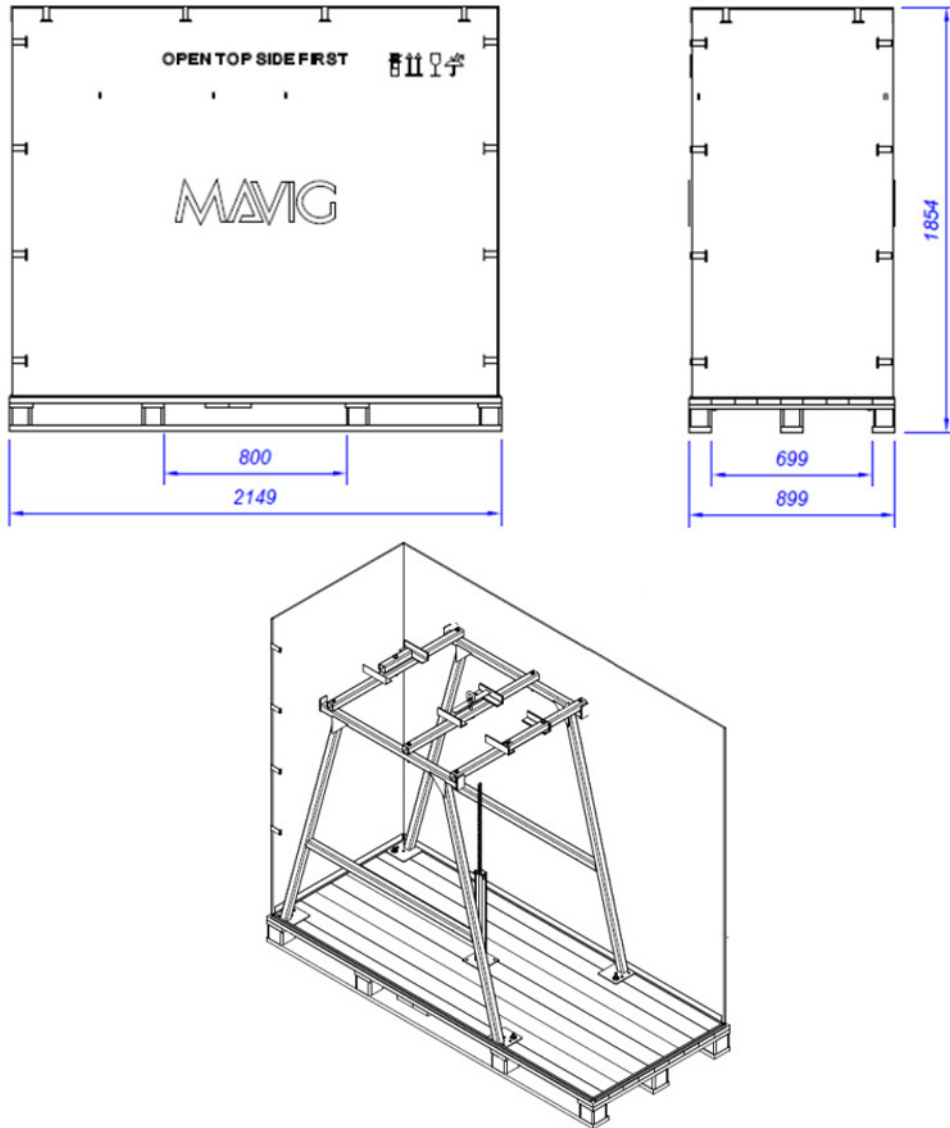

### 1.3.1.2.10 Other Elements Package

**NOTE**

All OEM parts are shipped inside there original boxes group as needed on pallets.

Figure 13 Other Standard Shipping Box

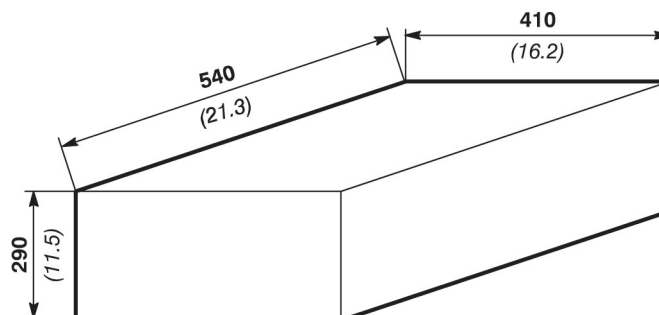

### 1.3.2 Tools and Test Equipment

Refer to [Table 2 on page 17](#). To obtain a list of tools and test equipment for components not specified in [Table 2 on page 17](#), refer to the appropriate component Pre-Installation Manual.

Table 2

PRODUCT OR COMPONENT	TOOL OR TEST EQUIPMENT	USED FOR	SOURCE	RECEIVED (DATE)
All	Service Engineer's Tool Case	General Use		
Innova LC Positioner	Level, Protractor Type	Positioner Checks		
	Torque Wrench 2 to 20 daN.m (15 ft. lbs. to 150 ft. lbs.)	Positioner Checks		
	1/2 inch Ratchet Wrench	Raise and Lower Positioner shipping dolly		
	InGrid/HV Tank "Chucking tool" or wrench, P/N 2131328	High Voltage Cable Installation		
	Laptop Computer	Positioner Configuration and Calibration		
Omega/Innova <sup>IQ</sup> Table and Innova <sup>IQ</sup> OR Table	Same as for Innova LC (Service Engineer's Tool Case) Fill in any additional tools or test equipment as required			
	Installation dolly (PN 5265134)	Replacing Omega with Innova <sup>IQ</sup> Table or Innova <sup>IQ</sup> OR Table		
Monitor Suspension	Ladders	Installation		

continued				
PRODUCT OR COMPONENT	TOOL OR TEST EQUIPMENT	USED FOR	SOURCE	RECEIVED (DATE)
	(For Suspension with rails) XT Lifting Tool (x2) 46-156940G3	Installation		
	(For LDM Suspension with fixed point Dual Arm) Installation tool and Pelicase (P/N 5758418)	Installation		

### 1.3.3 Door Size Requirements

Minimum door sizes also apply to hallways and elevators. For additional details, refer to [1.3.1 Shipping Information on page 5](#).

#### 1.3.3.1 Door Height

The minimum door height shall be determined to accommodate for the following components:

- The Innova Gantry on its dolly: **2 m** (79 in).
- The C-FRT Cabinet on its pallet: **2.20 m** (87 in).

If the door height is not sufficient, you may need to put the C-FRT Cabinet on its wheels (refer to [Figure 40 on page 55](#) and to *IST0527 - C-FRT Cabinet Installation* in the Service Manual).



Adhere to the limit of use described in the Installation Job card.

#### 1.3.3.2 Door Width

The minimum door width needed (to accommodate the Innova LC shipping dolly) is:

- 1.165 m (46 in) with protective side rail,
- 1.096 m (43 in) with one protective side rail removed on site.

#### NOTE

Door widths are based on a straight-in approach requiring a 2.44 m (96 in) wide corridor. Calculations need to be made for accommodation of equipment through narrower corridors.

## 1.3.4 Route Survey

### 1.3.4.1 Step One — Sketch

Start preparing Route Survey by sketching a floor plan of the hospital or clinic which will receive the equipment. Include all areas on the delivery route from outside the building to destination. See [Figure 14 on page 19](#).

Reference Numbers: Numbers in circles refer to Route Survey data. The Route Survey is a form on which site data are listed (see [Step Two — Survey on page 19](#)).

Figure 14

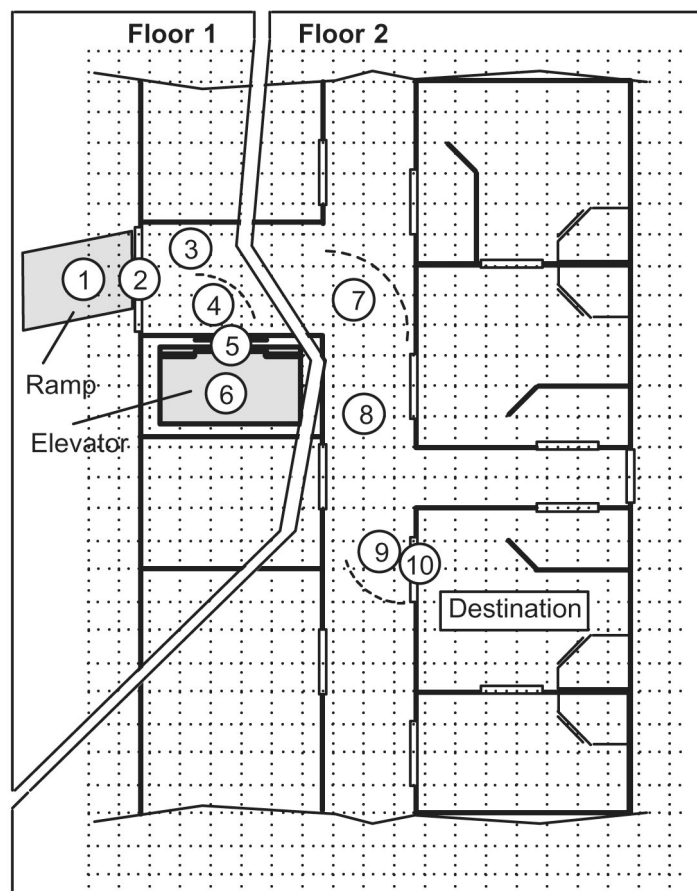

### 1.3.4.2 Step Two — Survey

Data concerning the intended delivery route are recorded on the Route Survey in the following pages. Record all loading capacities, corridor widths, door openings, turning radii, flooring materials, elevator sizes, obstructions and so on.

### 1.3.4.3 Step Three — Check

Verify equipment can be transported via the route specified in [Step One — Sketch on page 19](#). Compare Route Survey compiled in [Step Two — Survey on page 19](#) to equipment specifications in this and other applicable pre-installation directions.



**Table 4 Transport Requirement**

Component	TEMPERATURE		HUMIDITY		PRESSURE	
	MIN	MAX	MIN	MAX	MIN	MAX
All components except UPS, monitors and detector	-20°C (-4°F)	+55°C (+131°F)	10%	95%	700 hPa	1030 hPa
All UPS	-20°C (-4°F)	+40°C (+104°F)	10%	90%	700 hPa	1030 hPa
All Monitors	-20°C (-4°F)	+55°C (+131°F)	10%	80%	700 hPa	1030 hPa
Detector	+10°C (+50°F)	+40°C (+104°F)	10%	90%	700 hPa	1030 hPa

## 1.4.2 System Storage

If storing a system prior to installation, the system shall be stored in its original packaging in a temperature and humidity controlled environment protected from water and dust.

**Table 5 Storage Requirement**

Component	TEMPERATURE		HUMIDITY		PRESSURE	
	MIN	MAX	MIN	MAX	MIN	MAX
All components	+10°C (+50°F)	+40°C (+104°F)	10%	80%	700 hPa	1030 hPa

It is recommended that the temperature for storage does not exceed +25°C (+77°F).

Systems with the Fluoro UPS shall be stored for less than 6 weeks if the storage temperature is above 30°C (86°F), and less than 12 weeks if the storage temperature is above +25°C (+77°F).

Systems with the 1 kVA UPS or 8 kVA UPS shall be stored for less than 14 weeks if the storage temperature is above 30°C (86°F), and less than 25 weeks if the storage temperature is above +25°C (+77°F).

The overall storage time for the system shall be less than 6 months.

### Special instructions for the detector:

The detector is shipped separately from the system and is very sensitive to temperature and humidity, as irreparable damage to the detector scintillator will occur. As defined in [Table 5 on page 21](#), it shall be stored between +10 and +40°C (+50 to +104°F) and less than 80% RH inside its unopened shipping box, the lowest temperature and humidity being preferable. If it is to be stored outside of its shipping box or if the plastic wrapping has been removed, it should be stored at +20°C (68°F) or less and 30% RH or less.

### 1.4.3 Handling instructions

The packaging of the following components must be marked with special handling instructions for transport:

- NPA PDU

Figure 15 NPA PDU - Labels on packaging

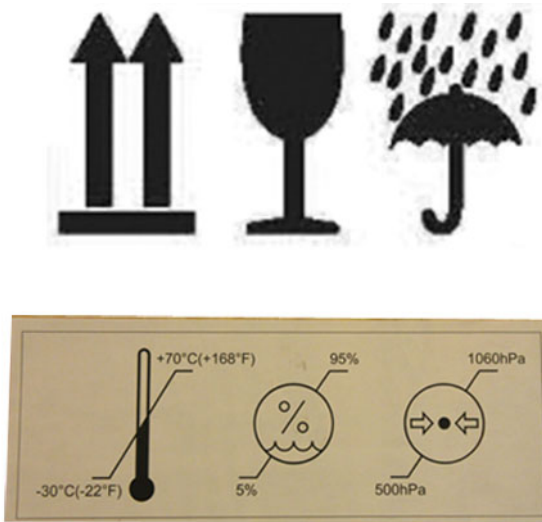

- C-FRT Cabinet

Figure 16 C-FRT Cabinet - Labels on packaging

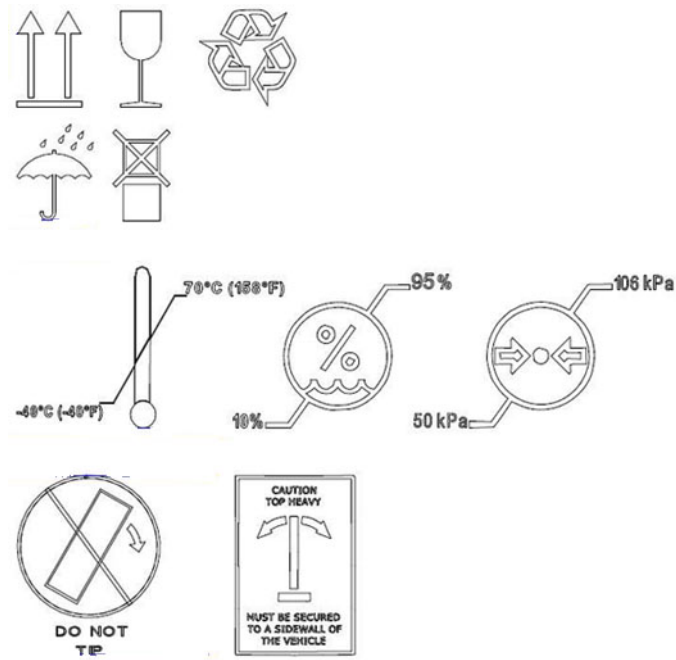

- Gantry

Figure 17 Gantry - Label on packaging

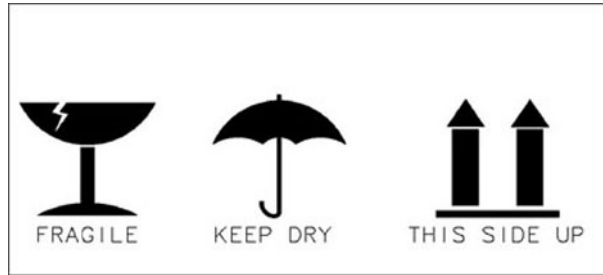

- Patient Table

Figure 18 Patient Table - Label on packaging



Page intentionally left blank

# Chapter 2 Equipment Requirements

## 2.1 System Components

### 2.1.1 Presentation of the 3 Rooms

The components shall be installed in three different rooms with different constraints: the Exam Room, the Control Room and the Technical Room.

#### 2.1.1.1 Exam Room

This is where the patient is situated. It contains the table on which the patient is lying, the table side user interfaces (TSUI), the gantry, the exam monitors, and accessories.

#### 2.1.1.2 Control Room

This room contains user interface and control monitors. No intentional or unintentional contact with the patient shall occur with the patient in this area.

#### 2.1.1.3 Technical Room

This room contains electronic cabinets. No intentional or unintentional contact with the patient shall occur with the patient in this area. It is strongly recommended that this room is separated from the Control Room, in order to minimize risks of transmission of airborne pathogens. Its construction should be adapted to minimize ambient noise level; for example the use of glass doors instead of louvered hung doors.

## 2.1.2 Description of Innova System

### 2.1.2.1 Core system

#### 2.1.2.1.1 Gantry

Figure 19 Gantry

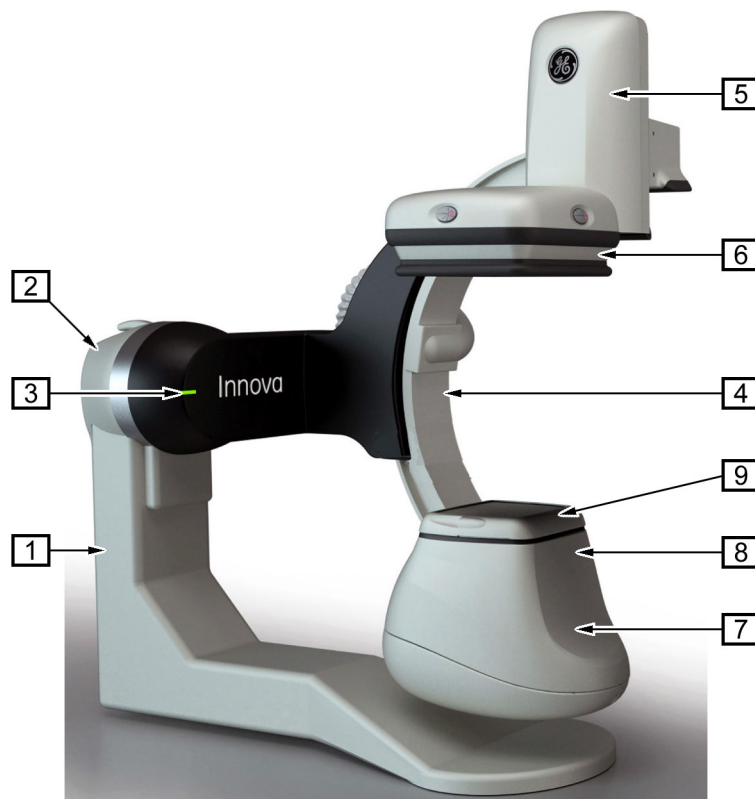

1. L-arm
2. Pivot
3. X-Ray LED
4. C-Arc
5. Motorized Elevator for the Detector
6. Detector 21 cm, 31 cm or 41 cm
7. X-Ray Tube
8. Collimator
9. X-Ray Tube cover spacer

### 2.1.2.1.2 Patient Table

Patient Table depends on your System.

**Table 6 Compatibility matrix for Patient Table**

	Innova IGS 520	Innova IGS 530	Innova IGS 540
OMEGA IV Compact Table	Yes	No	No
OMEGA V long Table	Yes	Yes	Yes
Innova <sup>IQ</sup> Table	Yes	Yes	Yes
Innova <sup>IQ</sup> OR Table	Yes	Yes	Yes

**Figure 20 Omega Table (with TSSC)**



Table System Side Control (TSSC)

**Figure 21 Innova<sup>IQ</sup> Table**



Figure 22 Innova<sup>IQ</sup> OR Table



### 2.1.2.1.3 User Interfaces

Figure 23 User Interfaces



Smart Handle



Smart Box



Table Side Control (TSSC)



Table Panning Device (TPD)



Intelligent Touchscreen Unit (ITU)



Table footswitch



Remote Box for Omega table

or



Remote Box for InnovalQ table and InnovalQ OR table

### 2.1.2.1.4 Accessories for Innova<sup>IQ</sup> Table and Innova<sup>IQ</sup> OR Table

Figure 24



Figure 25



### 2.1.2.1.5 Monitors

By default:

- Two 19" monitors are provided in the Exam Room:

## Equipment Requirements

- LIVE monitor,
- REVIEW monitor.
- Two 19" monitors are provided in the Control Room:
  - LIVE monitor,
  - DL monitor.

### 2.1.2.1.6 Electronic Cabinets

The following cabinets are provided with the system:

- C-FRT Cabinet, which contains the high voltage generator, 2 PCs, IT components and the boards for the Gantry and Table control.
- NPA PDU (Power Distribution Unit).
- One UPS among:
  - 1 kVA UPS for system safe shutdown
  - 8 kVA UPS to maintain all functions except X-Ray acquisitions during power failures
  - Fluoro UPS (2 different models for UL and CE markets): to complete an exam in fluoroscopy mode during power failures. The autonomy is 5 minutes of fluoroscopy every 24 hours.
- Tube Chiller.
- Detector Conditioner.

### 2.1.2.2 Options

#### 2.1.2.2.1 Large Display Monitor (LDM)

The system can integrate a Large Display solution to:

- see images larger at full IQ with greater flexibility in monitor distance in the procedure room.
- display multiple video images simultaneously at different sizes based on stage of workflow.
- conveniently switch operator defined video layouts at different points in procedure workflow.

This option consists in a 58" color monitor and 2 backup 19" monitors in the Exam Room. A second optional 58" monitor can be provided.

#### 2.1.2.2.2 User Interfaces

The user interfaces available on option are:

- In-room AW mouse interface kit.

#### **NOTE**

The dongle and the mouse are not provided in the kit.

- Bolus Handle.

Figure 26 Optional User Interfaces



In-room AW mouse interface kit

Bolus handle

### 2.1.2.2.3 Monitors

According to the subscribed options, up to 9 optional monitors can be installed:

- 1 additional 19" monitor in the Exam Room (Roadmap),
- up to 2 additional 19" monitors in the Control Room (Review and Roadmap),
- up to 6 additional 19" monitors in the Exam Room or in the Control Room.

Table 7 Location of 19" monitors (mandatory and optional)

Video Splitter Output	Output 1	Output 2	Output 3	Output 4
Live	<b>Exam Room</b>	<b>Control Room</b>	Exam Room or Control Room	Exam Room or Control Room (1)
Review	<b>Exam Room</b>	Control Room	Exam Room or Control Room	Exam Room or Control Room (1)
Roadmap	Exam Room	Control Room	Exam Room or Control Room	Exam Room or Control Room (1)

#### NOTE

Text in **bold** for mandatory 19" monitors.

(1): without LDM option.

### 2.1.2.2.4 Monitor Suspensions

GE provides as option several types of suspensions; alternatively, the customer can install the suspension of his choice (third party monitor suspension), provided all requirements in the paragraph [Third party monitor suspension according to GEHC specifications on page 34](#) are met.

#### 2.1.2.2.4.1 19" monitors suspension (without LDM)

The system can be equipped with a suspension for 4 monitors or 6 monitors.

The common type of this suspension is an XT inboard monitor bridge. A monitor frame support receiving 4 or 6 monitors (fixed monitor suspension).

These suspensions are delivered and installed by GE.

### **2.1.2.2.4.2 LDM suspension**

For the systems with the LDM option, a specific suspension can be provided:

- a suspension with rails
- a suspension with fixed point dual arm

These suspensions are delivered and installed by GE.

The two backup monitors are mounted on the back of this suspension for faster access in case of failure.

For the second LDM, a wall mounting kit can be provided.

### **2.1.2.2.4.3 Third party monitor suspension according to GEHC specifications**

The systems can be provided with a kit to interface a third-party suspension. It allows to power two B&W 19" monitors, up to 4 additional in-room 19" monitors (B&W or Color), and up to 2 Large Display monitors on one or several third-party suspensions of customer choice, in addition or in replacement of the standard Mavig Suspension usually provided with the system. The live and review monitors are mandatory in the Exam Room.

Third party monitors from external sources can also be installed on these suspensions, but shall not be powered by the system.

Only the monitors provided with the system can be powered by the system:

- 19" monitors: Eizo RX150 GE or Eizo MX193,
- Large Display monitors: Eizo LS580W GE or Barco GEH-8258 L.



It is the customer responsibility to ensure that the following requirements are met:

- The suspension shall not be electrically motorized for up/down motion.
- The suspension shall comply with the IEC 60601-1 standard and the applicable standards enforced in the country of installation (e.g. when installed in a European Community country, the suspension(s) shall be CE marked). In addition, for North America each suspension shall comply with UL/Canada deviations.
- The suspension shall be manually adjustable in height and the force to be applied to lift the suspension when fully equipped shall not exceed 200 N in static in the vertical axis, in order to mitigate the risk of patient being jammed between the table and monitor suspension when the table is lifted up.
- Each suspension shall be installed in order to mitigate the risk of suspension fall on patients and the risk of collisions with the gantry, the table or any other suspension.
- The monitors and other parts attached to the suspension shall be compliant with the maximum load supported by the suspension.
- Each suspension shall be attached to the ceiling in accordance to the manufacturer's instructions. It shall withstand the maximum suspension load with safety factors in accordance to applicable standards (at least 4x).
- Each suspension shall be compatible with the Environmental Requirements chapter of the Pre- Installation Manual of the system.
- When the system is installed in an operating room (OR configuration), each suspension shall be compatible with OR environmental constraints.

The kits to interface a third-party suspension contain the following cables:

**Table 8**

	Destination	4 monitors	6 monitors	LDM
Power and Ground	PDU	30 m	30 m	36 m
Infrared Receiver	C-FRT	30 m	30 m	36 m
Optional dose displays	Dose monitor control device	2 x 30 m	2 x 30 m	2 x 36 m

continued				
	Destination	4 monitors	6 monitors	LDM
Video cables for system monitors (RJ45 cables)	C-FRT	4 x 30 m	6 x 30 m	2 x 36 m
VGA cables for third-party monitors	Third-party video sources	2 x 30 m	2 x 36 m	—

**NOTICE**

In order to maintain the IQ performance of the system, only the video cables for the system monitors shall be used. No extension or additional restpoint is allowed.

The mechanical installation of the third-party suspension and the electrical installation of the third-party monitors are fully under the customer and the installer responsibility. They shall ensure that the third-party suspension and its cables are installed prior to the GE equipment (gantry, table, cabinet) so that the standard GE Service Process can be followed during the system installation. Monitors installation and connections to the GE equipment shall only be made in presence of a GE service representative.

The customer is responsible for providing and replacing any parts of the third-party suspension and monitors.

The overhead monitor suspension shall be installed by strictly following the GEHC installation instructions. GE specifically disclaims any and all liability arising out of or relating to the use or performance of the monitor suspension (including cables), including, without limitation, any liability or claims relating to patient injury, death, or the reliability of such monitors suspension.

The association of Innova system delivered with kit to interface a third-party suspension and the customer monitors suspension(s), is not covered by the Innova product certification.

Type of fixation:

- 19" monitors: standard VESA 100 x 100 mm
- Large display monitors: standard VESA 400 x 400 mm.

Weight for the maximum load calculation (for the monitors, refer to [Components location and characteristics on page 38](#)).

**Table 9**

Part	Max Weight (kg)	Dimensions W x H x D (mm)
IR Receiver module	0.3	112 x 31 x 76
Dose display module	1	210 x 146 x 58

### 2.1.2.3 Advantage Windows workstation (AW)

The AW workstation option is composed of a workstation, 1 or 2 19" flat panel monitors in the Control Room.

One optional 19" flat panel monitor can be fixed on the Exam Room suspension, or both AW screens can be displayed on the LDM if the option is present.

## 2.1.2.4 CENTRICITY CA1000 option

Refer to :*Centricity Cardiology CA 1000 V2.0 Preinstallation Guide* in the OEMs of the Innova IGS 5 Service Manual.

## 2.1.2.5 Injectors

The injectors certified for use with the system are:

**Table 10**

Certified Injectors	Omega Table	Innova <sup>IQ</sup> Table	Innova <sup>IQ</sup> OR Table
MedRad Avanta (pedestal version)	Yes	Yes	Yes
MedRad Avanta (table mount version)	Yes	No	No
MedRad Mark 7 (table mount version)	Yes	Yes	Yes
MedRad Mark 7 (pedestal mount version)	Yes	Yes	Yes
Medrad Mark 7 (ceiling mount version)	Yes	Yes	Yes
Acist CVI (pedestal version)	Yes	Yes	Yes
Acist CVI (table mount version)	Yes	No	No

### NOTE

For MEDRAD Mark 7 table mount and ceiling mount, rack connected to C-FRT cabinet is located in technical room.

Table accessory rail load considerations:

Each table rail can withstand a load of 40 kg (88 lbs) at 150 mm (5.9") (60 N.m or 44.25 ft/lbs). Therefore, only a light load not exceeding 5 kg (11 lbs) at 100 mm (0.33 ft) can be mounted on the same table rail as the injector: for example IV pole with its accessories, pressure head, and so on. The front table rail is generally used for the TSUI, if needed an optional rail can be installed at table foot end of the Omega V table for other options.

The radiation protection and the injector shall never be installed on the same table rail.

## 2.1.2.6 Components location and characteristics

Table 11

PRODUCT OR COMPONENT	Number of components in:			NET WEIGHT kg (lbs)	DIMENSIONS WIDTH x DEPTH x HEIGHT mm (in)	LOAD ON THE FLOOR kg/m2 (lb/ft2)
	Exam room	Control room	Technical room			
Gantry	1	-	-	750 (1,655)	see Figure 27 on page 42, Figure 28 on page 42 and Figure 29 on page 43	2678 (549)
Omega Table	1	-	-	741.6 (1,635) See NOTE (1)	see Figure 30 on page 44 and Figure 32 on page 46	3065 (628)
Innova <sup>IQ</sup> Table		-	-	1017 (2,242) See NOTE (1)	see Figure 34 on page 48	2260 (463)
Innova <sup>IQ</sup> OR Table		-	-			
Footswitch	1	-	-	Not applicable	Not applicable	Not applicable
19" Monitors	2	1	-	5.5 (12)	Not Applicable	Not applicable
Smart Box or Smart Handle	1	-	-	6 (13)	Not applicable	Not applicable
TSSC	1	-	-	6 (13)	Not applicable	Not applicable
ITU	1	-	-	3.8 (8)	Not applicable	Not applicable
VCIM	-	1	-	0.95 (2.09)	450 (17.7) x 150 (5.9) x 50 (2)	Not applicable
DL Keypad	-	1	-	1.4 (3)	see Figure 50 on page 62	Not applicable

continued						
PRODUCT OR COMPONENT	Number of components in:			NET WEIGHT kg (lbs)	DIMENSIONS WIDTH x DEPTH x HEIGHT mm (in)	LOAD ON THE FLOOR kg/m2 (lb/ft2)
	Exam room	Control room	Technical room			
DL Monitor	-	1	-	8.2 (18)	see Figure 51 on page 63	Not applicable
C-FRT Cabinet	-	-	1	531 kg (without LDM) 536 kg (with LMM802) 541 kg (with LMM56800)	see Figure 40 on page 55	643 (132)
NPA PDU	-	-	1	285 (628)	see Figure 41 on page 56	847 (173)
1 kVA UPS	-	-	1	14.5 (32)	see Figure 42 on page 56	Not applicable
8 kVA UPS	-	-		84 (185)	see Figure 43 on page 57	Not applicable
Fluoro UPS UL	-	-		530 (1,169)	see Figure 44 on page 58	975 (200)
Fluoro UPS CE	-	-		480 (1,059)	see Figure 45 on page 59	883 (181)
Tube Chiller	-	-	1	120 (265)	see Figure 46 on page 60	424 (87)
Detector Conditioner	-	-	1	14.6 (32)	see Figure 47 on page 60	Not applicable
OPTIONS						
Monitors						
19" Monitors with stand	1 in Exam Room only Up to 2 in Control Room only Up to 6 in Exam Room or in Control Room		-	9.2 (20)	Not applicable	Not applicable

continued						
PRODUCT OR COMPONENT	Number of components in:			NET WEIGHT kg (lbs)	DIMENSIONS WIDTH x DEPTH x HEIGHT mm (in)	LOAD ON THE FLOOR kg/m2 (lb/ft2)
	Exam room	Control room	Technical room			
LD Monitor	Up to 2	-	-	47 (103)	Not applicable	Not applicable
User Interfaces and accessories						
Additional Smart Box or Smart Handle	1 in Exam room <b>or</b> 1 in Control room		-	6 (13)	Not applicable	Not applicable
Additional TSSC	1 in Exam room <b>or</b> 1 in Control room		-	6 (13)	Not applicable	Not applicable
Bolus Handle	1	-	-	Not applicable	Not applicable	Not applicable
In-room AW mouse interface kit	1		-	Not applicable	Not applicable	Not applicable
Table Side Cart	1	-	-	Not applicable	Not applicable	Not applicable
ECG Acquisition Device Modules						
Hubican	-	1	-	Not applicable	see <a href="#">Figure 52 on page 64</a>	Not applicable
Physio box	1		-	Not applicable		Not applicable
Suspension						
Precabled 19" LCD monitor suspension for 4 monitors	1	-	-	102 (225)	see <a href="#">Figure 53 on page 65</a>	Not applicable
Precabled 19" LCD monitor suspension for 6 monitors	1	-	-	115 (254)	see <a href="#">Figure 54 on page 66</a>	Not applicable
Precabled LD suspension with rails (self weight without monitor and accessories given)	1	-	-	215 (474)	see <a href="#">Figure 55 on page 67</a>	Not applicable

continued						
PRODUCT OR COMPONENT	Number of components in:			NET WEIGHT kg (lbs)	DIMENSIONS WIDTH x DEPTH x HEIGHT mm (in)	LOAD ON THE FLOOR kg/m2 (lb/ft2)
	Exam room	Control room	Technical room			
Precabled LD Mavig suspension with fixed point dual arm	1	-	-	190 (419)	see Figure 56 on page 68	Not applicable
Substructure for Dual Arm suspension (for LD Mavig suspension with fixed point dual arm)	1	-	-	58 (128)	see Figure 57 on page 69	Not applicable

**NOTE**

(1) Including patient weight. Patient weight considered is:

- 204 kg (450 lbs) for Omega Table,
- 250 kg (551 lbs) for Innova<sup>IQ</sup> Table and Innova<sup>IQ</sup> OR Table.



THE COMPONENTS IDENTIFIED AS TO BE INSTALLED IN THE TECHNICAL ROOM ARE NOT CERTIFIED FOR USE OUTSIDE OF THIS AREA. IT IS MANDATORY TO INSTALL THEM IN THE TECHNICAL ROOM.

## 2.1.3 Dimension Drawings

Figure 27 Gantry dimensions: - Side View

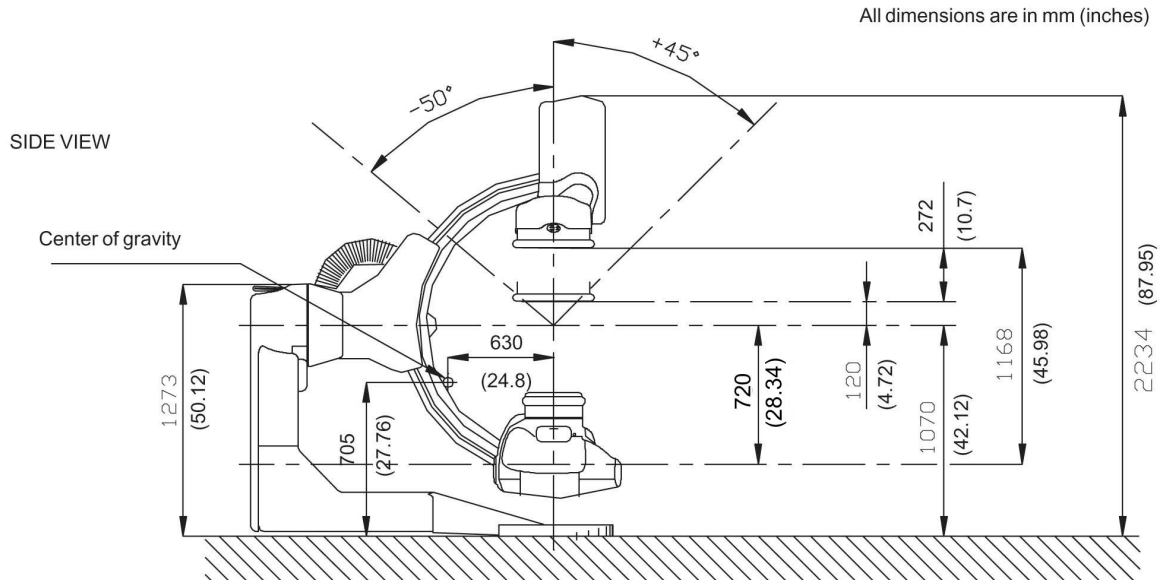

Figure 28 Gantry dimensions: - Top view

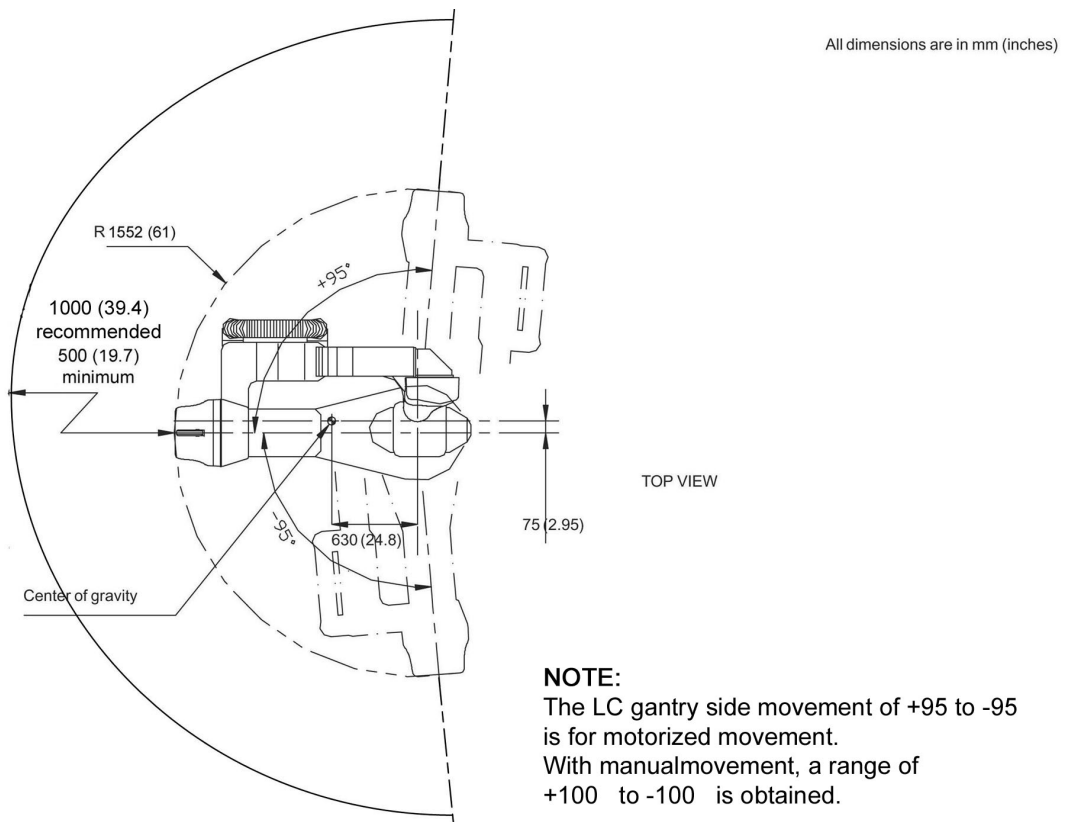

Figure 29 Gantry dimensions: - Front view

All dimensions are in mm (inches)

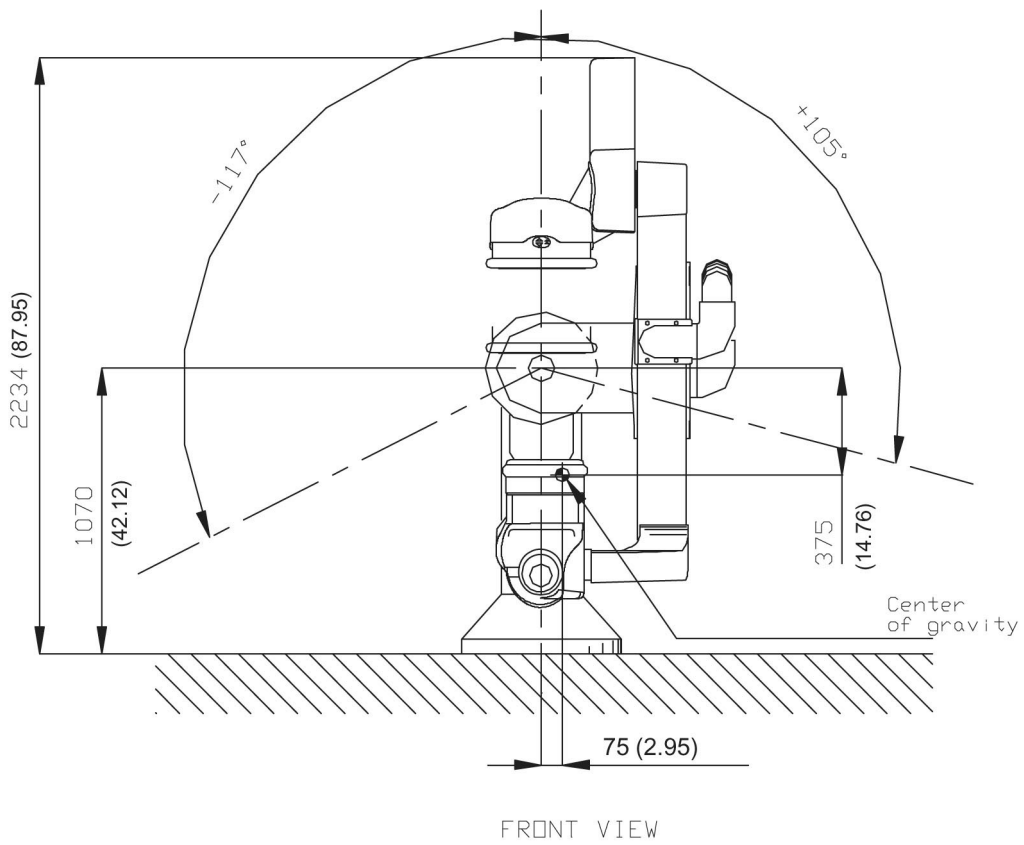

Figure 30 Omega IV Compact Patient Table dimensions

All dimensions are in mm (inches)

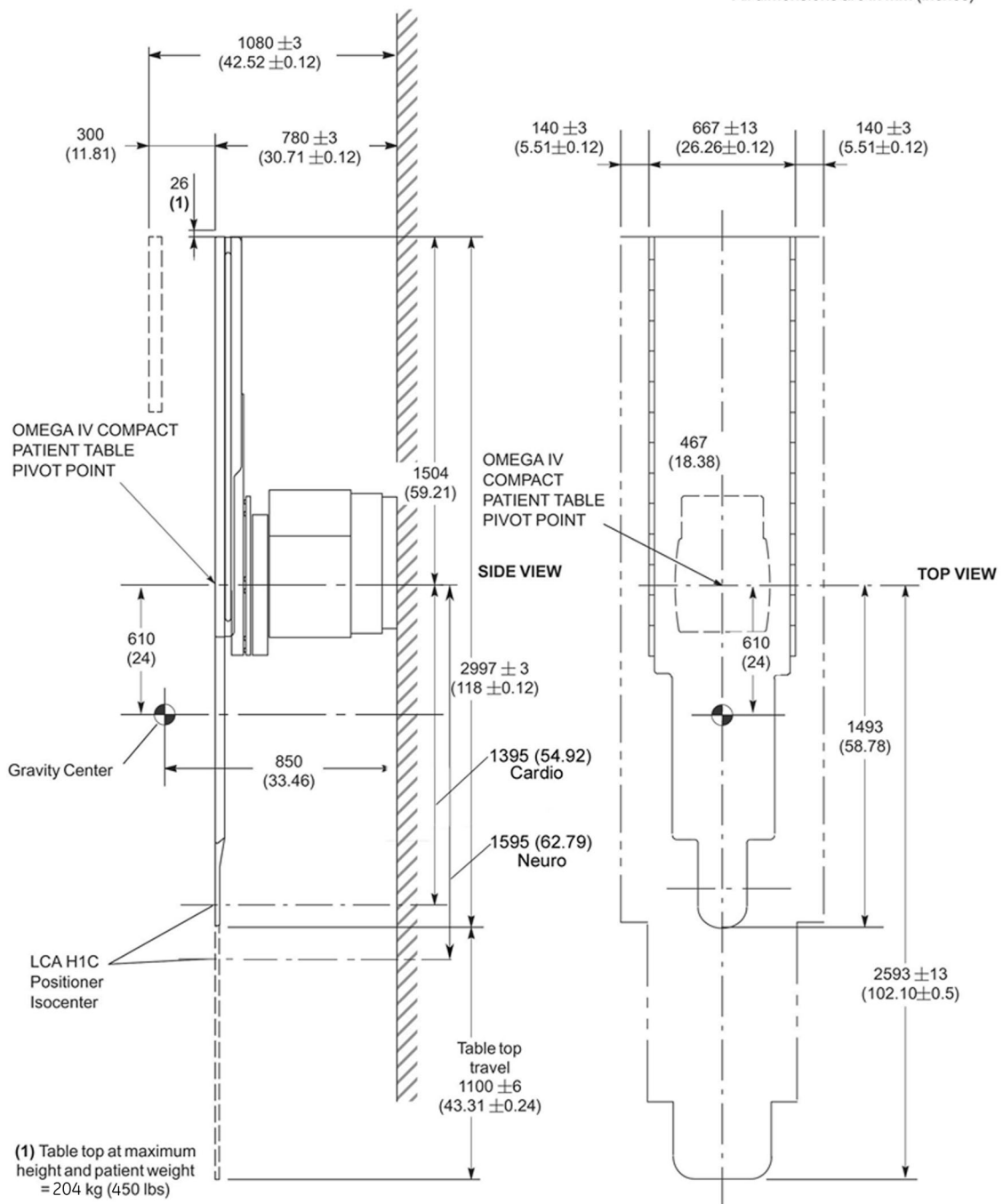

Figure 31 Omega IV Compact Patient Table Interference Regions (Innova IGS 520)

All dimensions are in mm (inches)

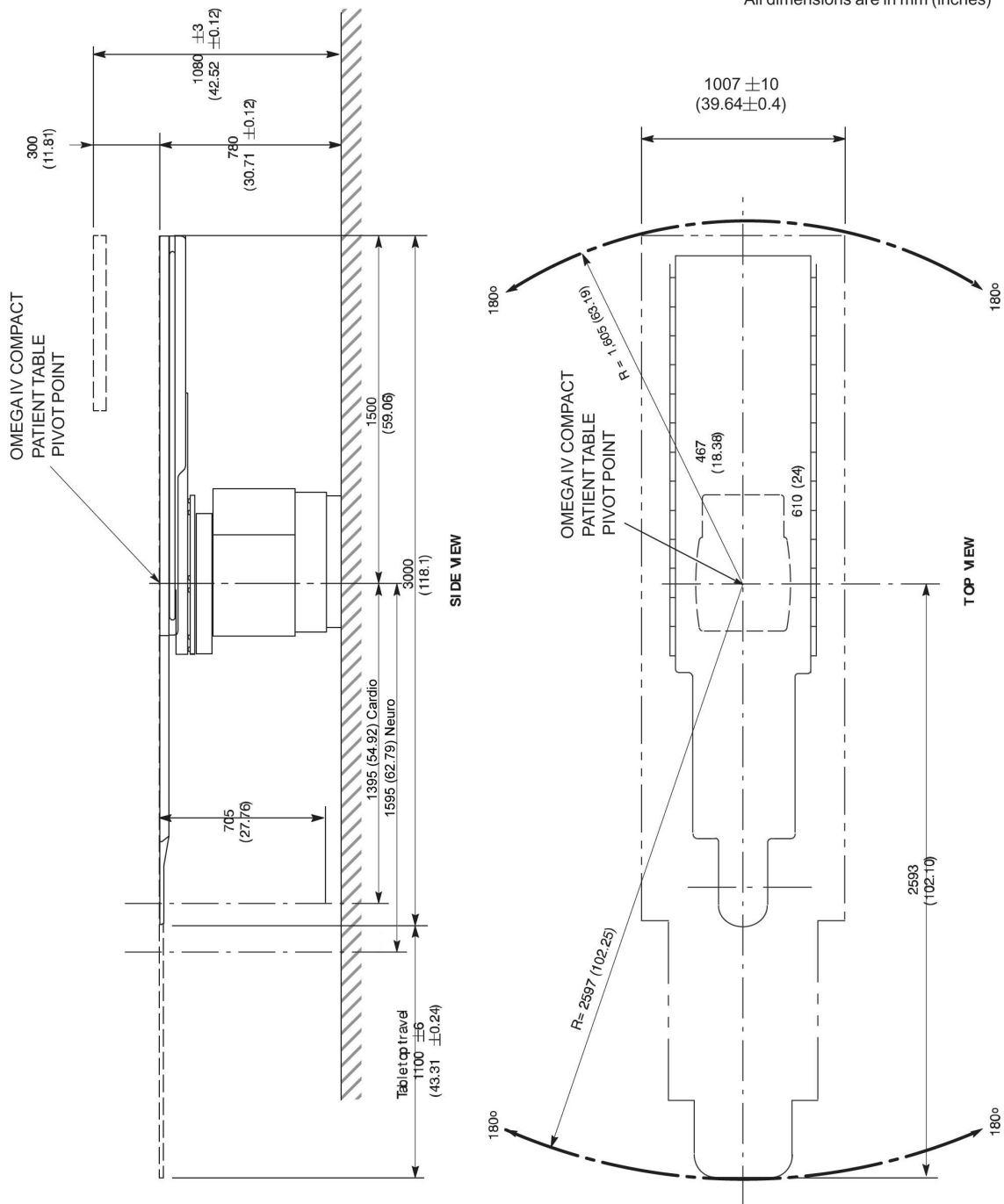
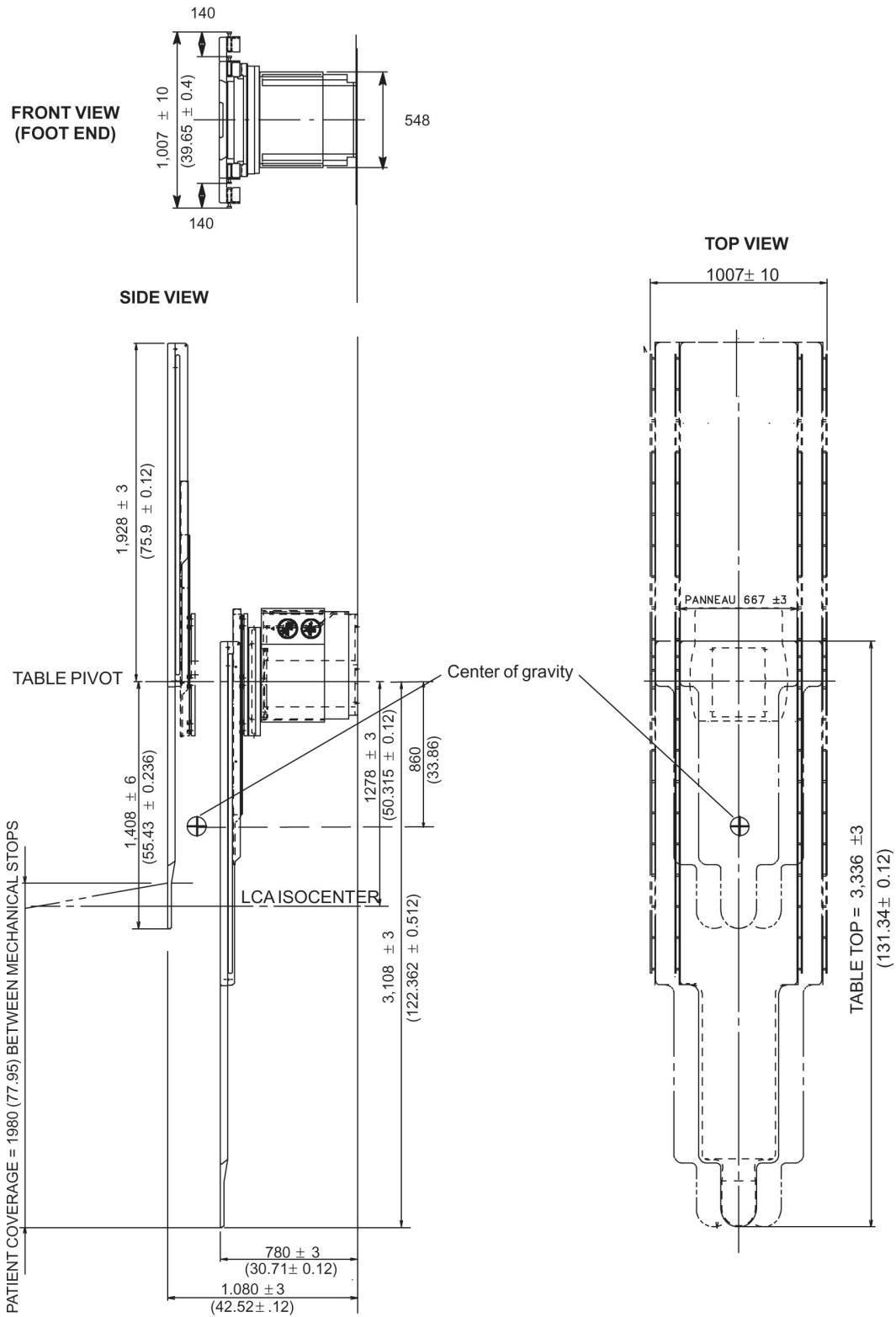

Figure 32 Omega V Long Patient Table dimensions



All dimensions are in mm (inches)

Figure 33 Omega V Long Patient Table Interference Regions

All dimensions are in mm (inches)

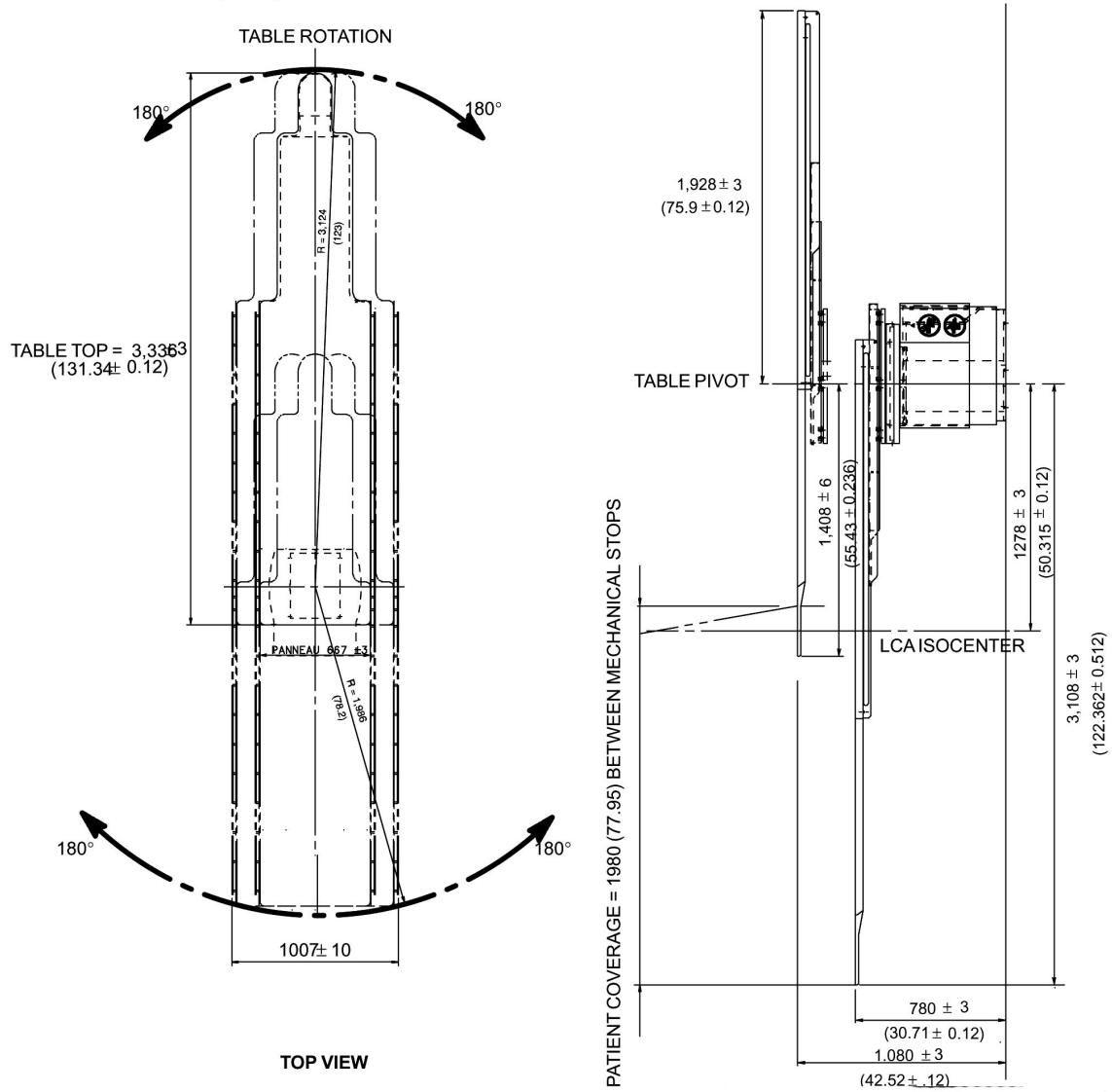
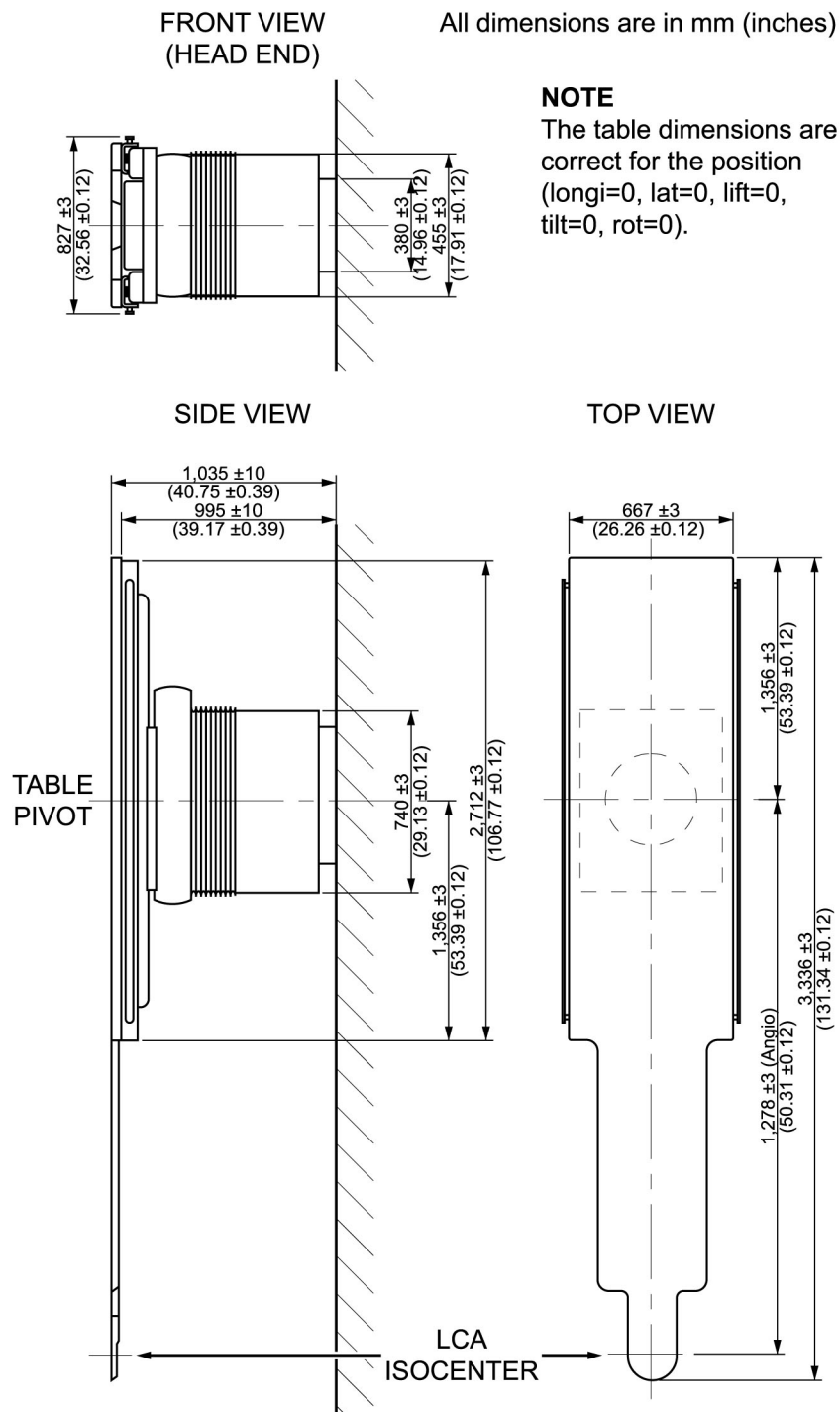

Figure 34 Innova<sup>IQ</sup> and Innova<sup>IQ</sup> OR Table dimensions



**NOTE**

With a Innova<sup>IQ</sup> Table and Innova<sup>IQ</sup> OR Table, the minimum distance from table pivot to the medical Gas Box is 600 mm and the maximum dimensions of the medical Gas Box are:

- height = 305 mm
- width = 250 mm
- length = 500 mm

Figure 35 Innova and Innova OR Table Interference Regions

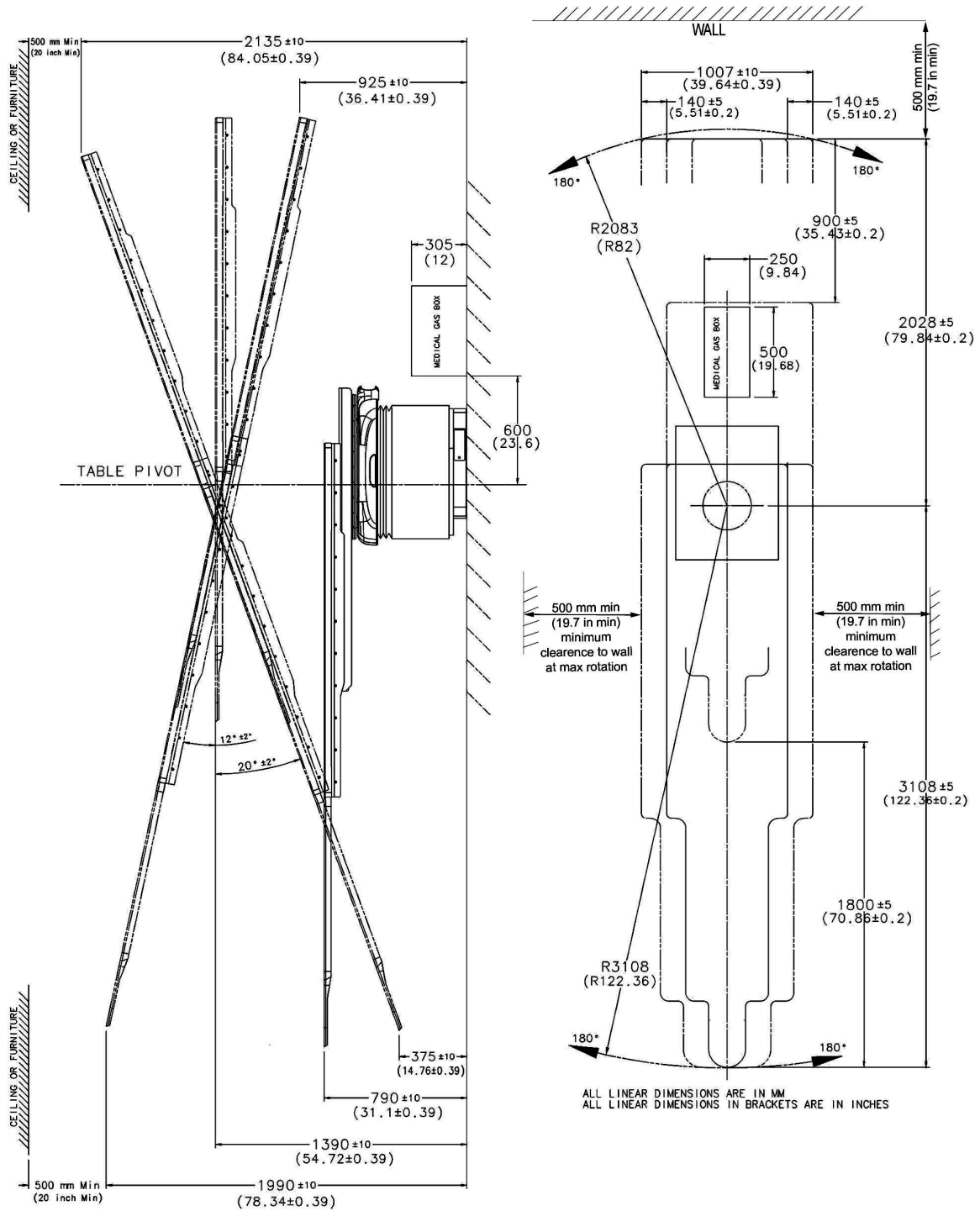

Figure 36 Patient Table side clearance (CPR access)

All dimensions are in mm (inches)

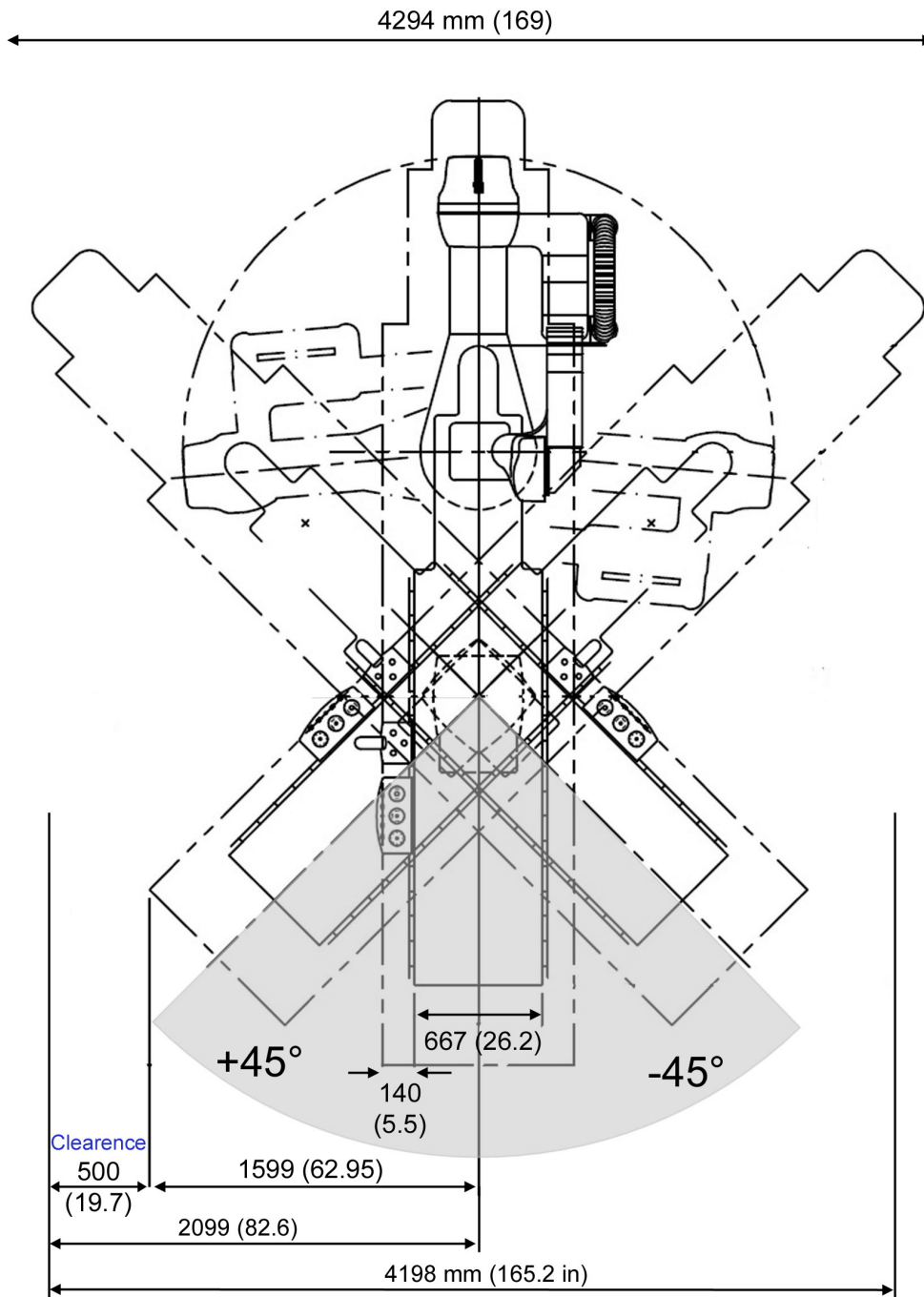

Figure 37 Table Head Extender dimensions

All measurements are in mm (inches)  
Based on drawing 5262690ADW

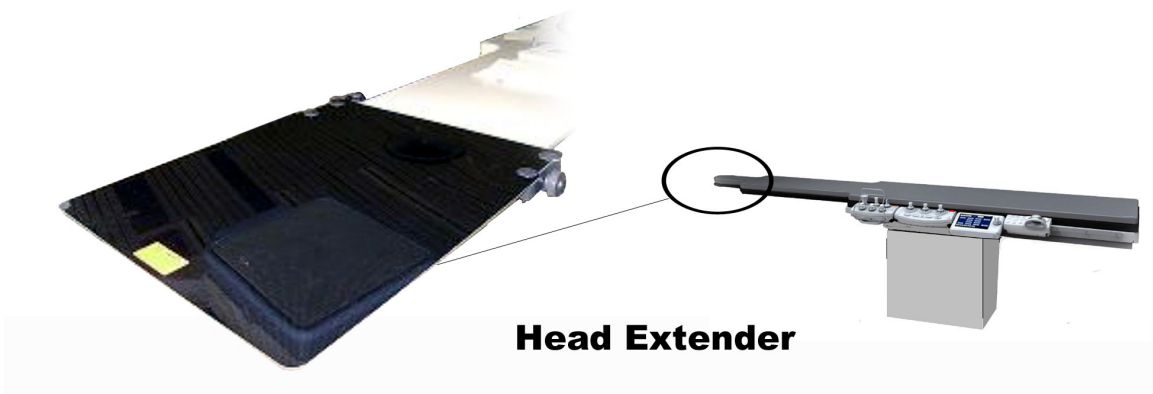
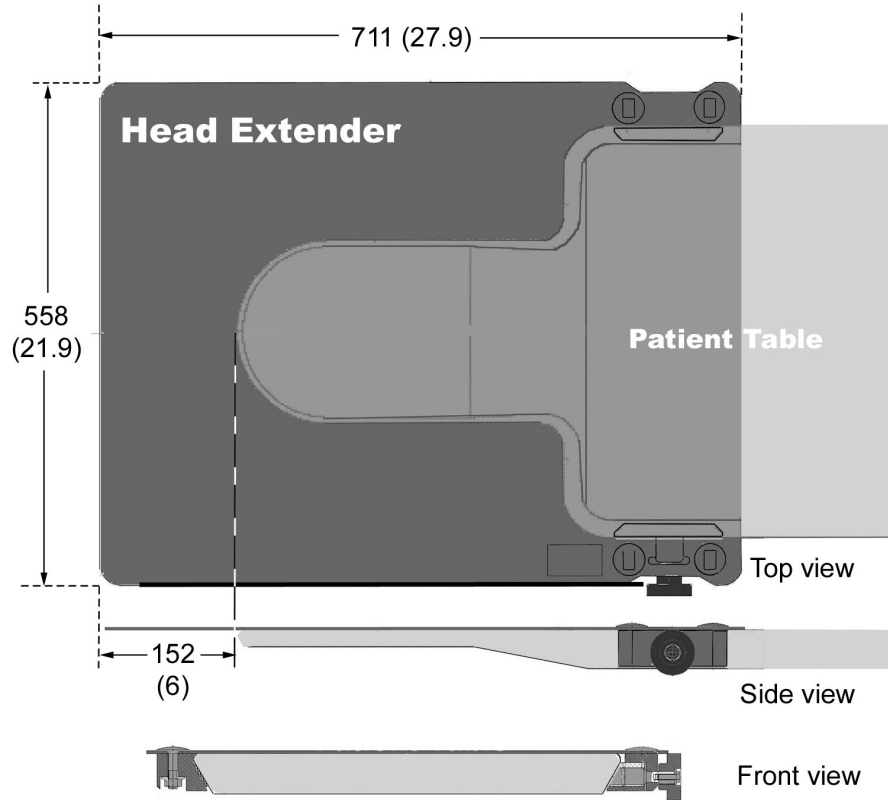
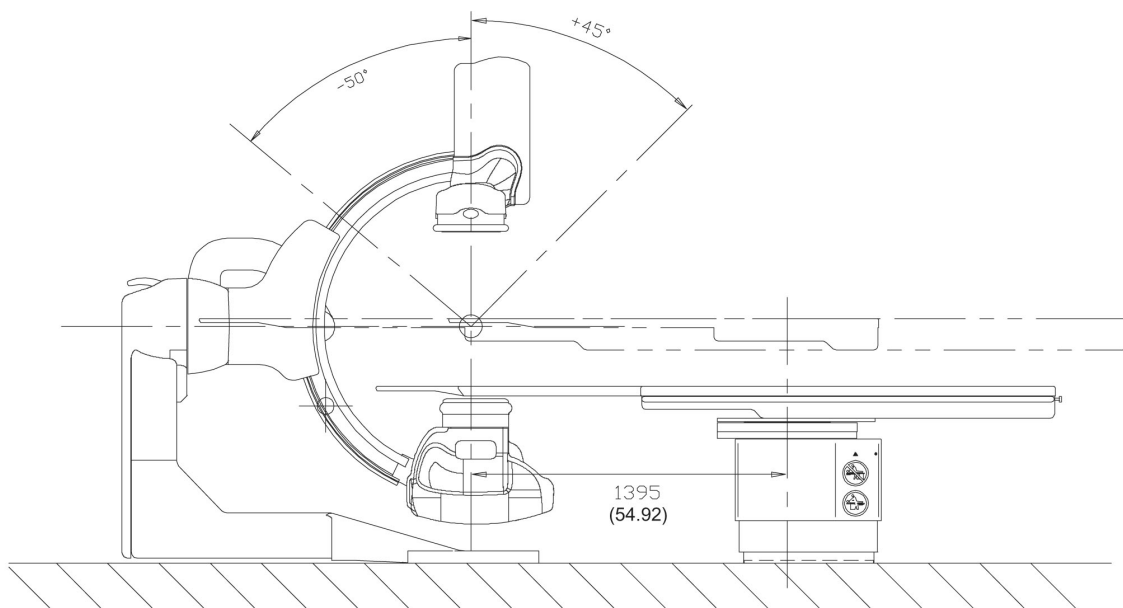

Figure 38 Gantry and Omega IV Compact Patient Table Relative Positions (Innova IGS 520) - Side View

All dimensions are in mm (inches)



**SIDE VIEW**

Figure 39 Gantry and Omega V Long Patient Table Relative Positions - Side View

All dimensions are in mm (inches)

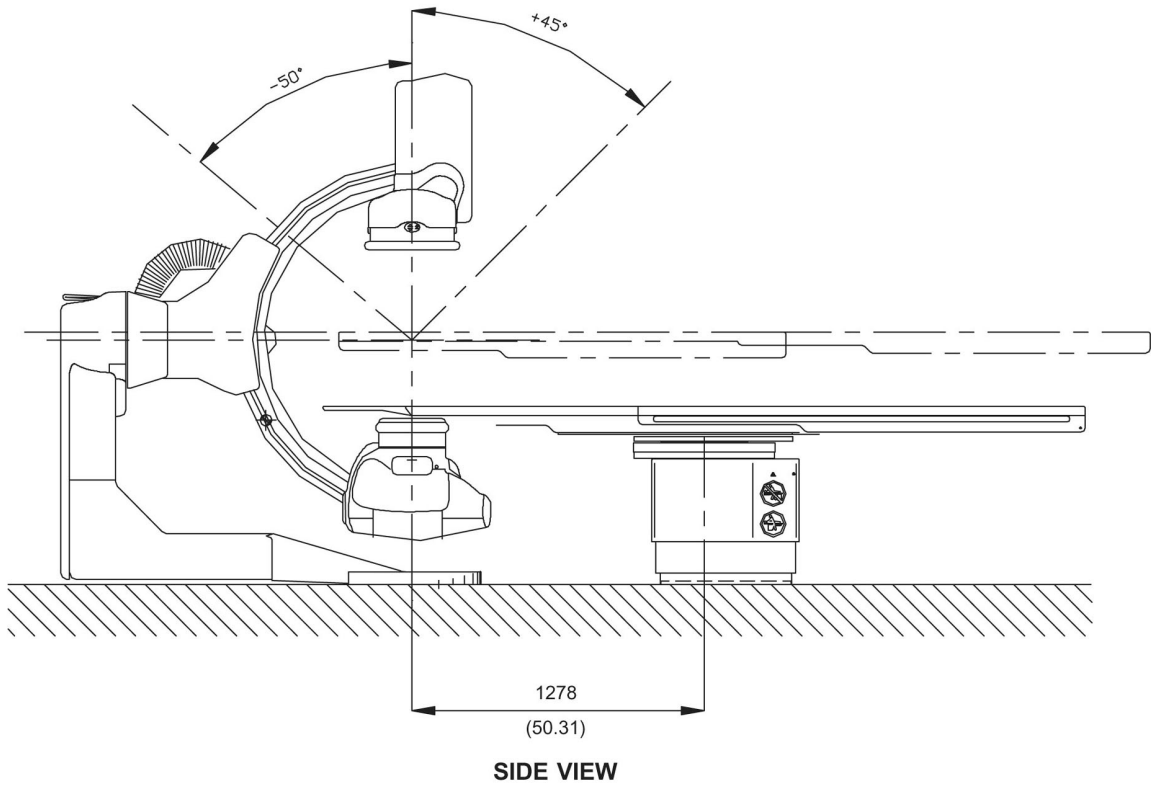
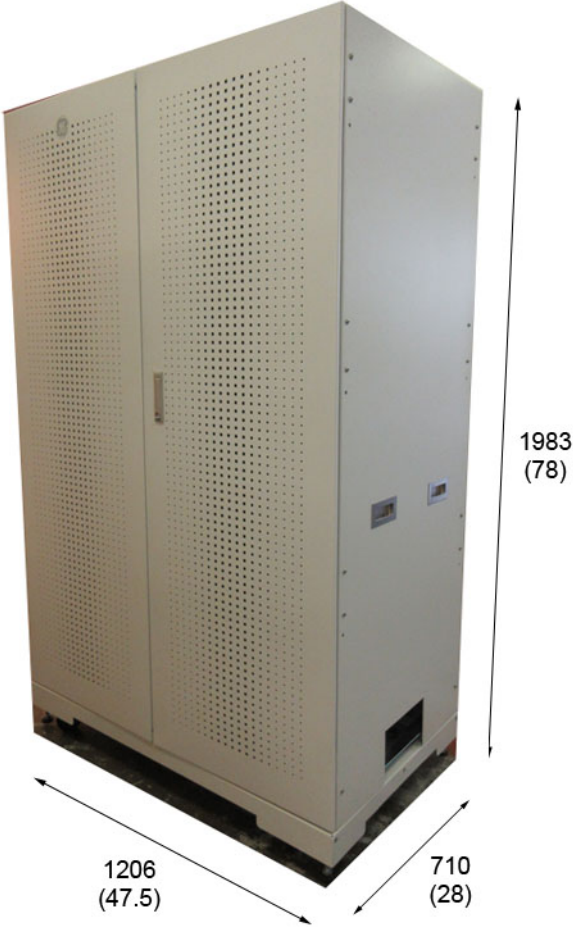
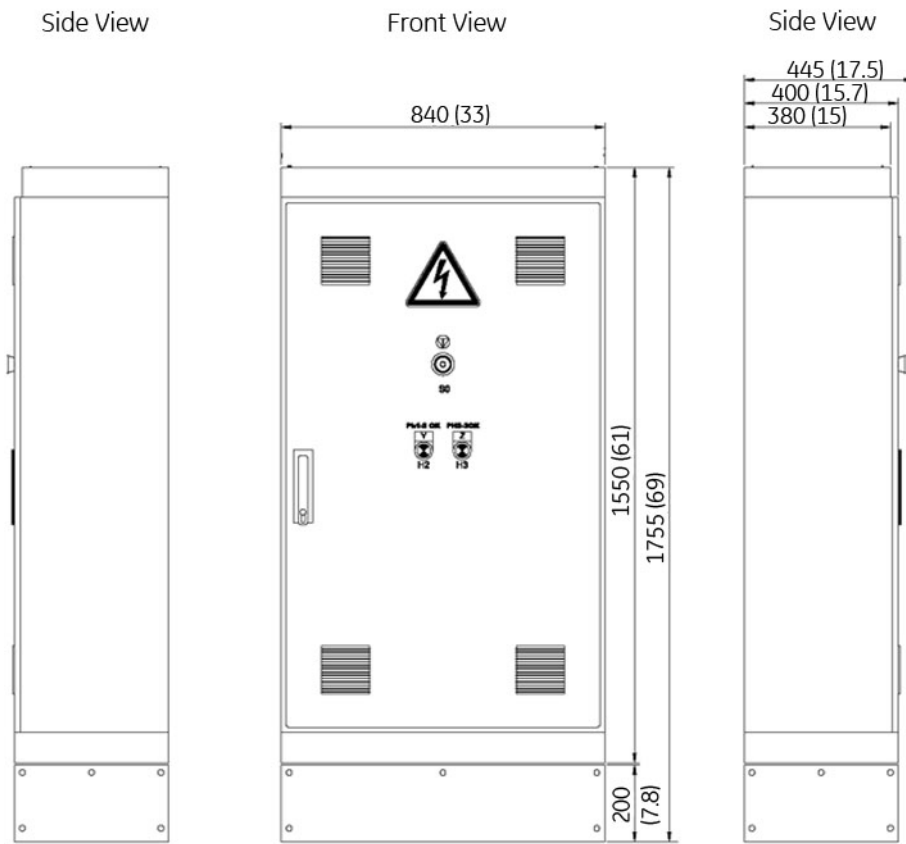

Figure 40 C-FRT Cabinet dimensions



Dimensions in mm (in)

**Figure 41 NPA PDU dimensions**



Dimensions in mm (in)

**Figure 42 1 kVA UPS dimensions**

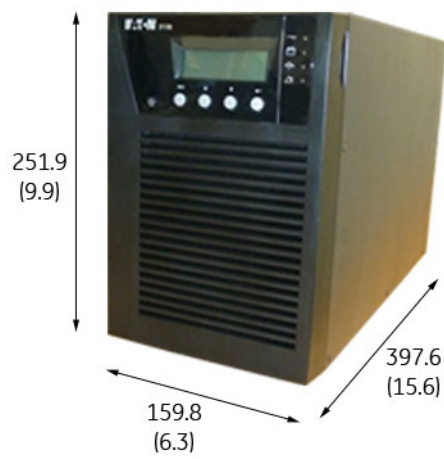

Dimensions in mm (in)

Figure 43 8 kVA UPS dimensions

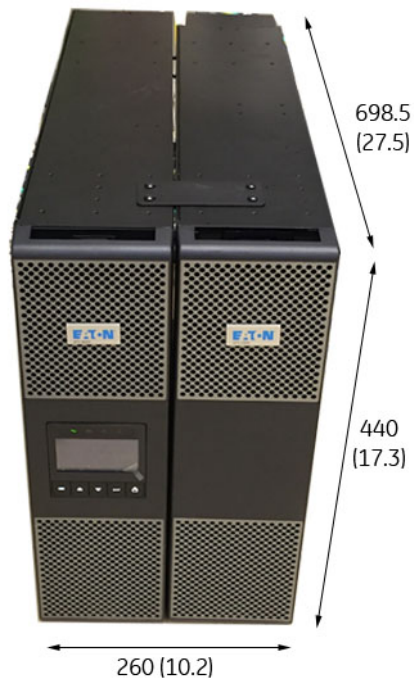

Dimensions in mm (in)

Figure 44 Fluoro UPS UL dimensions

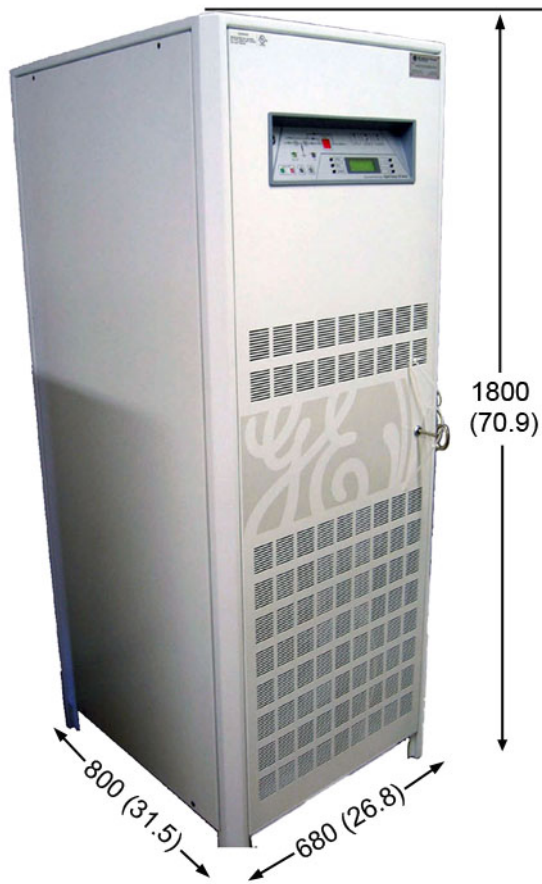

Dimensions in mm (in)

Figure 45 Fluoro UPS CE dimensions



**NOTE**

A Fire extinguisher (non-water type, ex. CO<sup>2</sup>) must be installed close to the Fluoro UPS CE cabinet.

Figure 46 X-Ray Tube Chiller dimensions

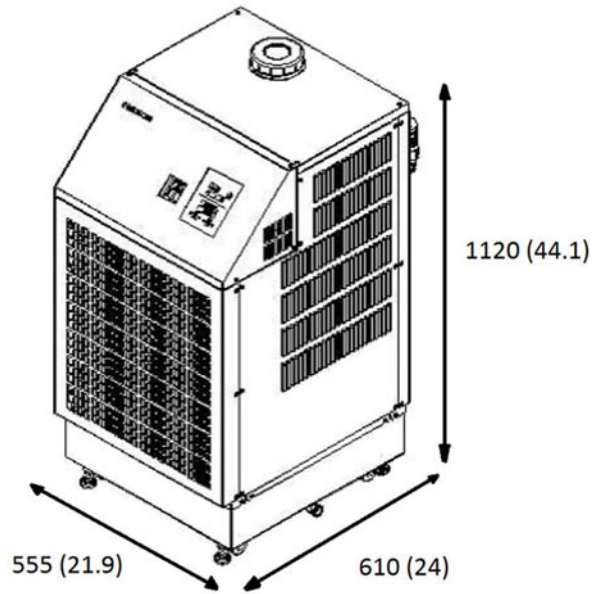

Dimensions in mm (in)

Figure 47 Detector Conditioner dimensions

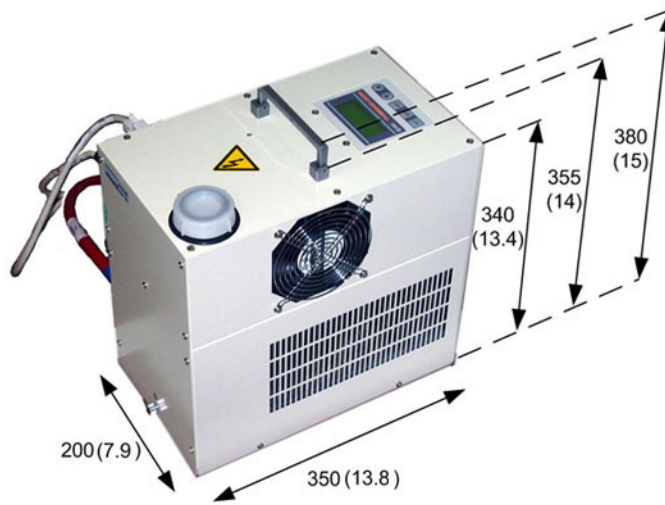

Dimensions in mm (in)

Figure 48 Gas box outlets Omega IV

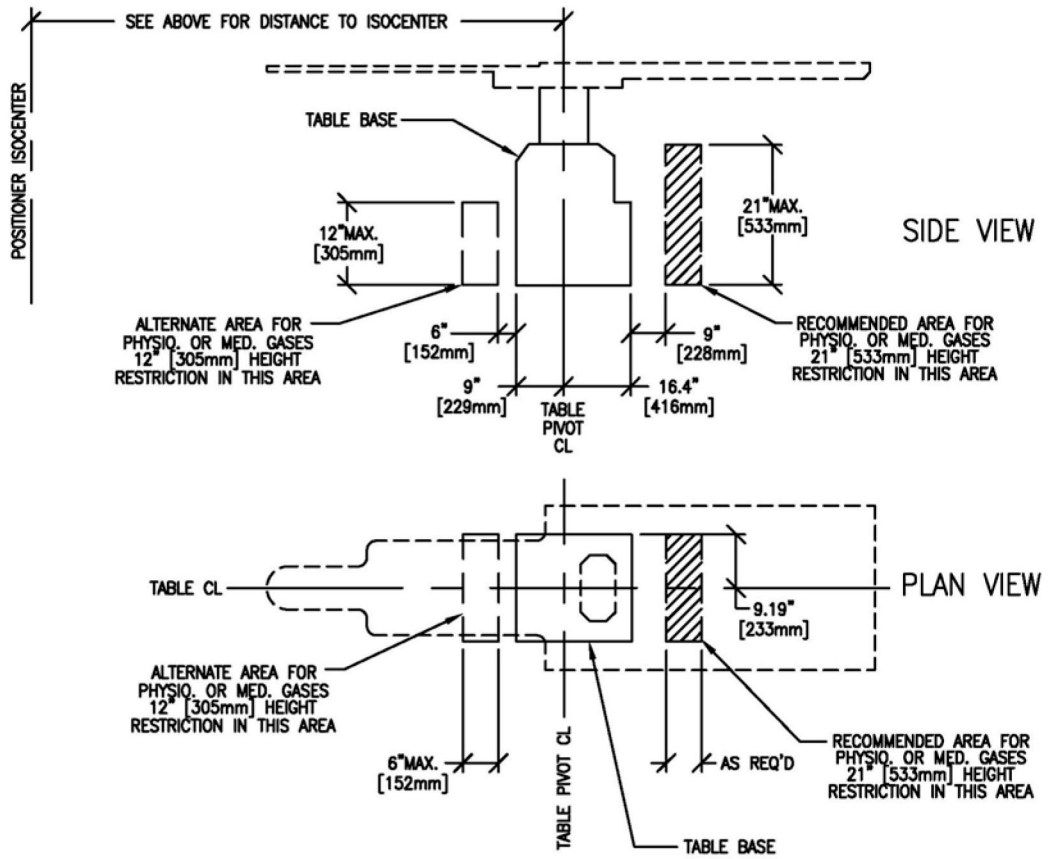

Figure 49 Gas box outlets Omega V

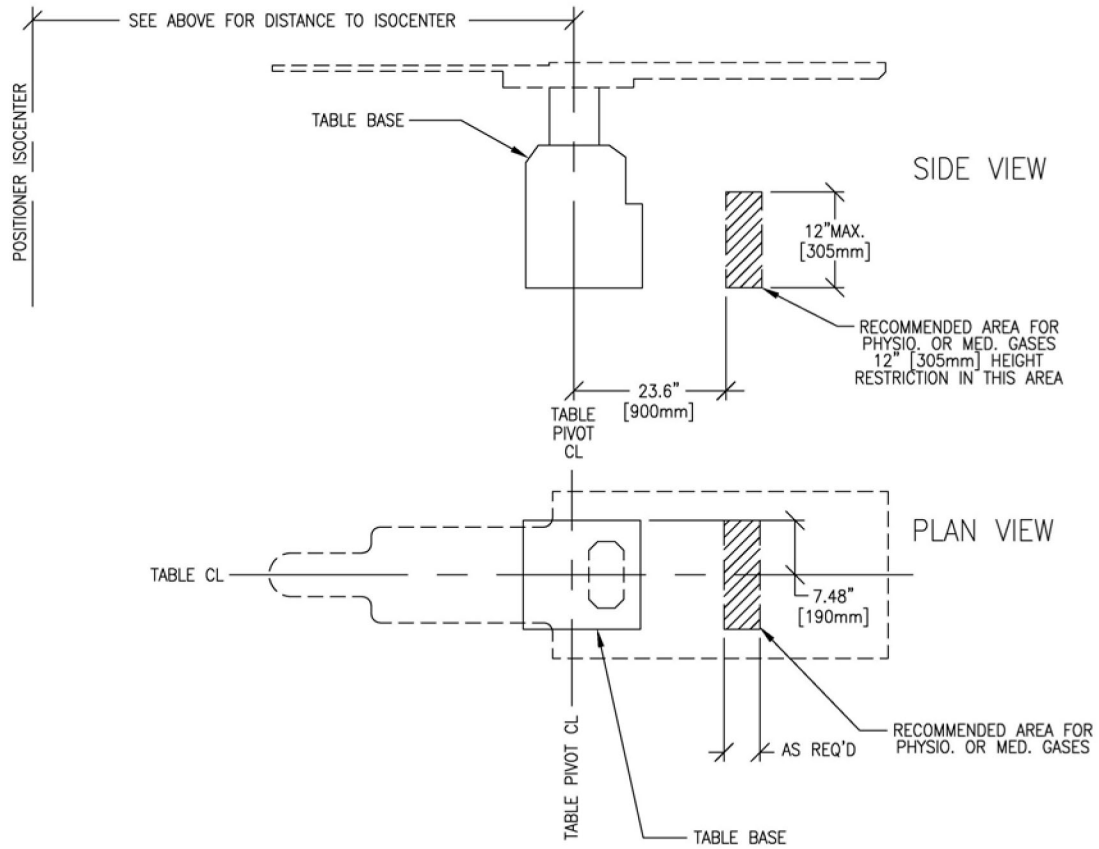
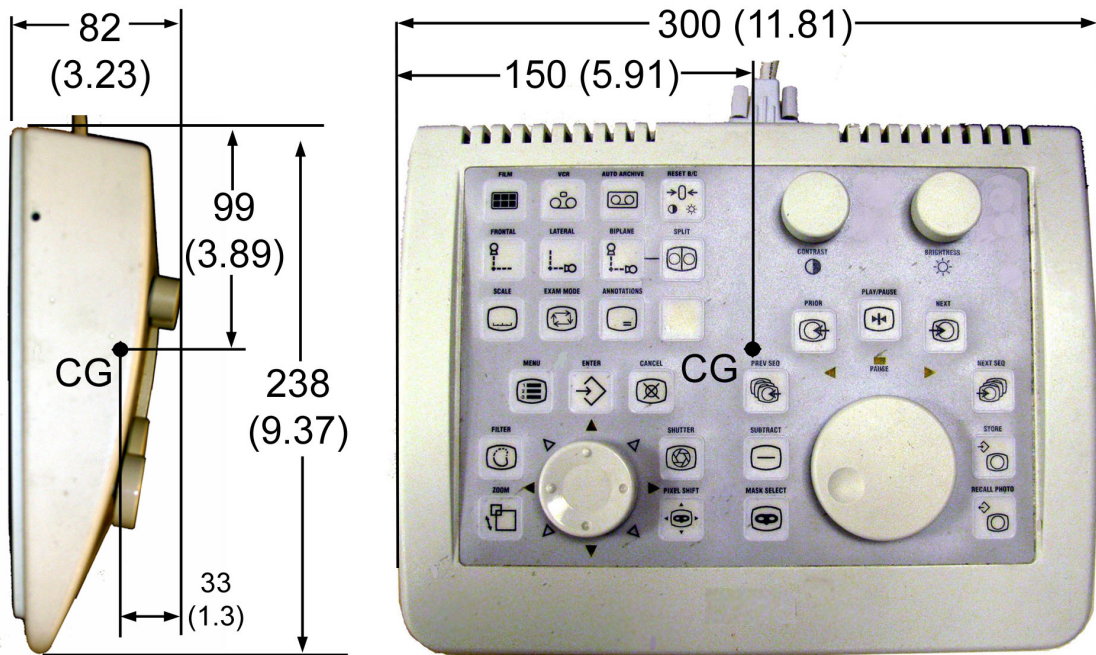

Figure 50 DL Keypad dimensions



All dimensions are in mm (inches)

Figure 51 DL Image Monitor dimensions

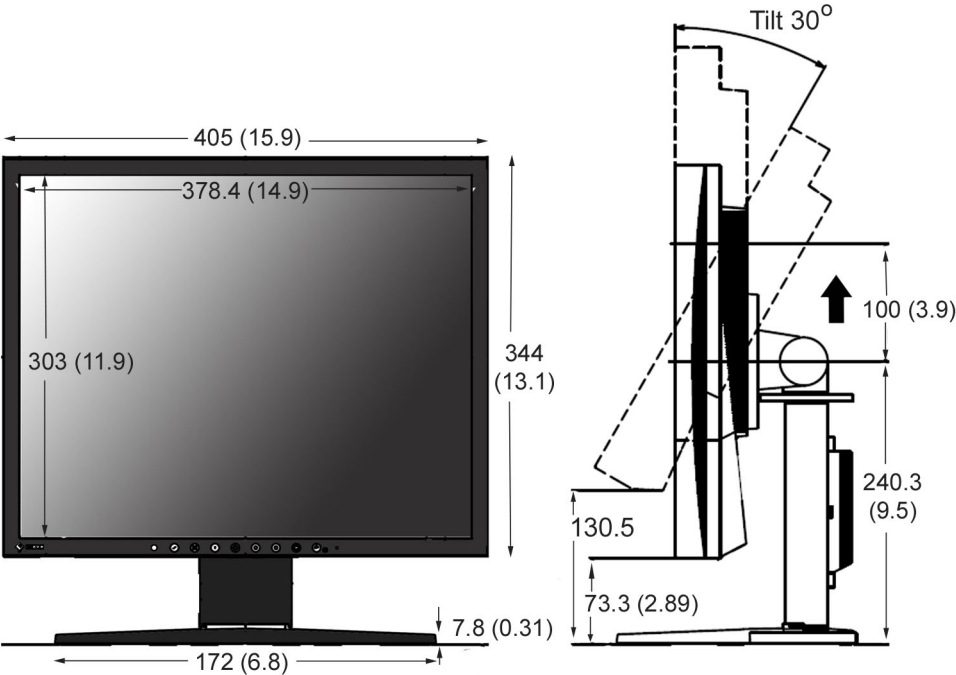
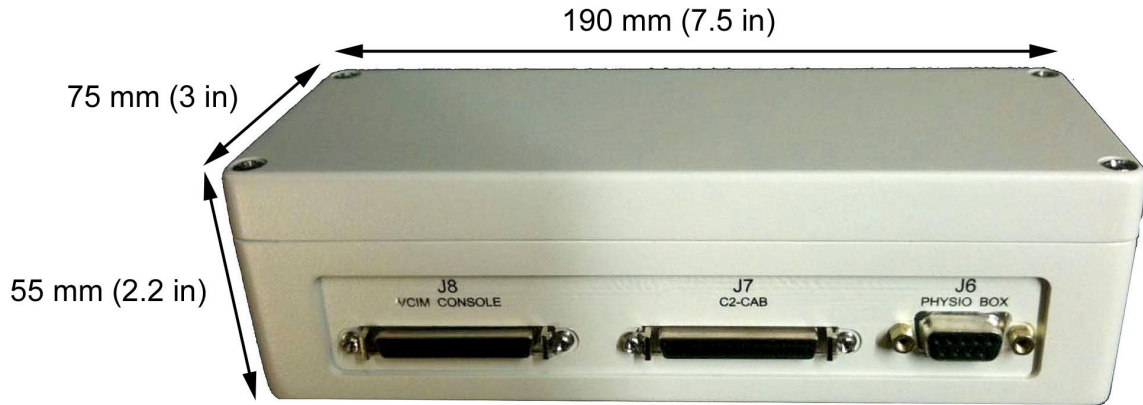
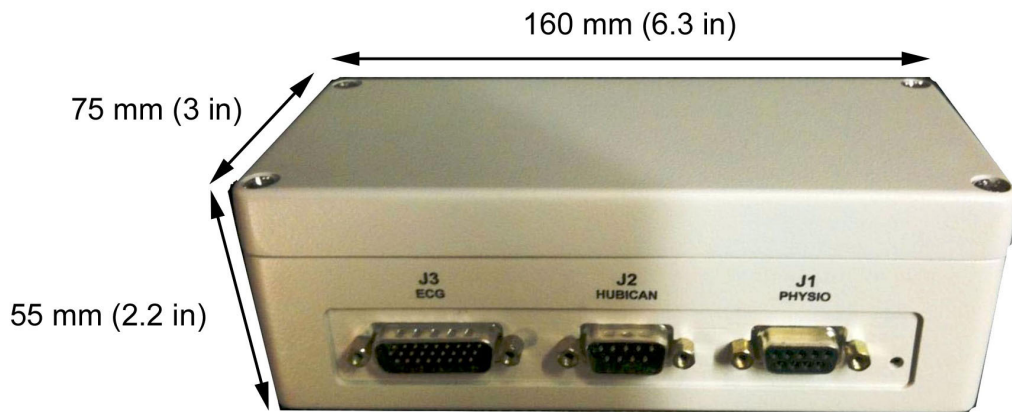

Figure 52 ECG Acquisition Device Modules dimensions



Hubican Module



Physio Module

Figure 53 LCD 4 monitors suspension dimensions (Optional)

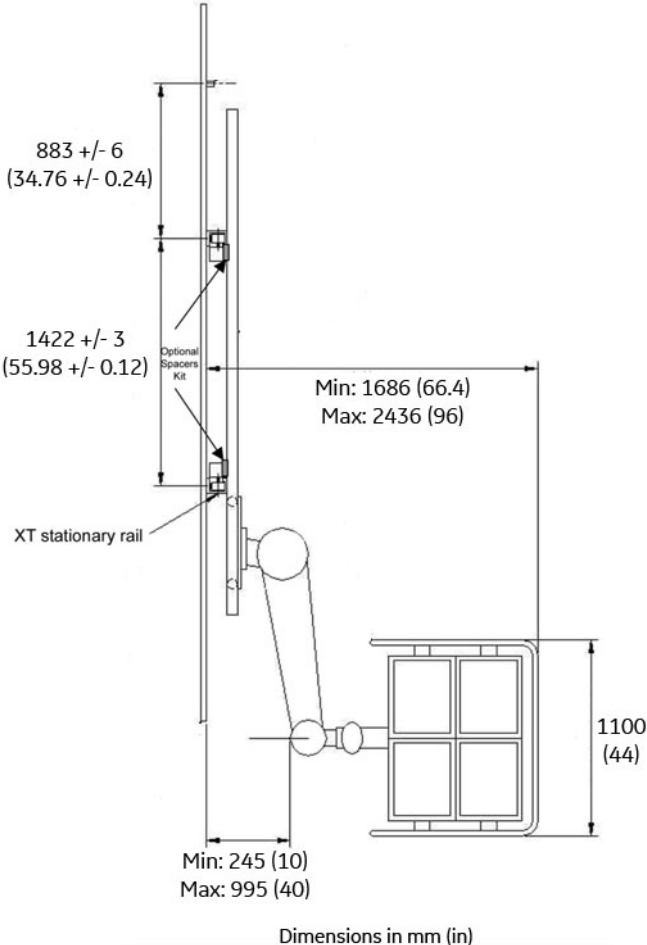

Figure 54 LCD 6 monitors suspension dimensions (Optional)

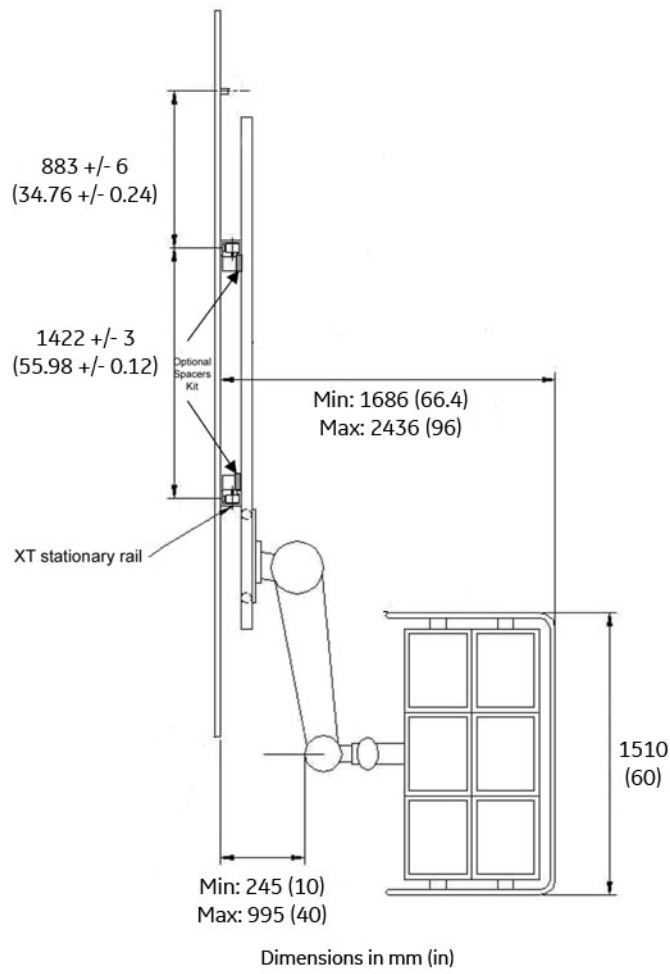

Figure 55 Large Display Suspension with rails dimensions (Optional)

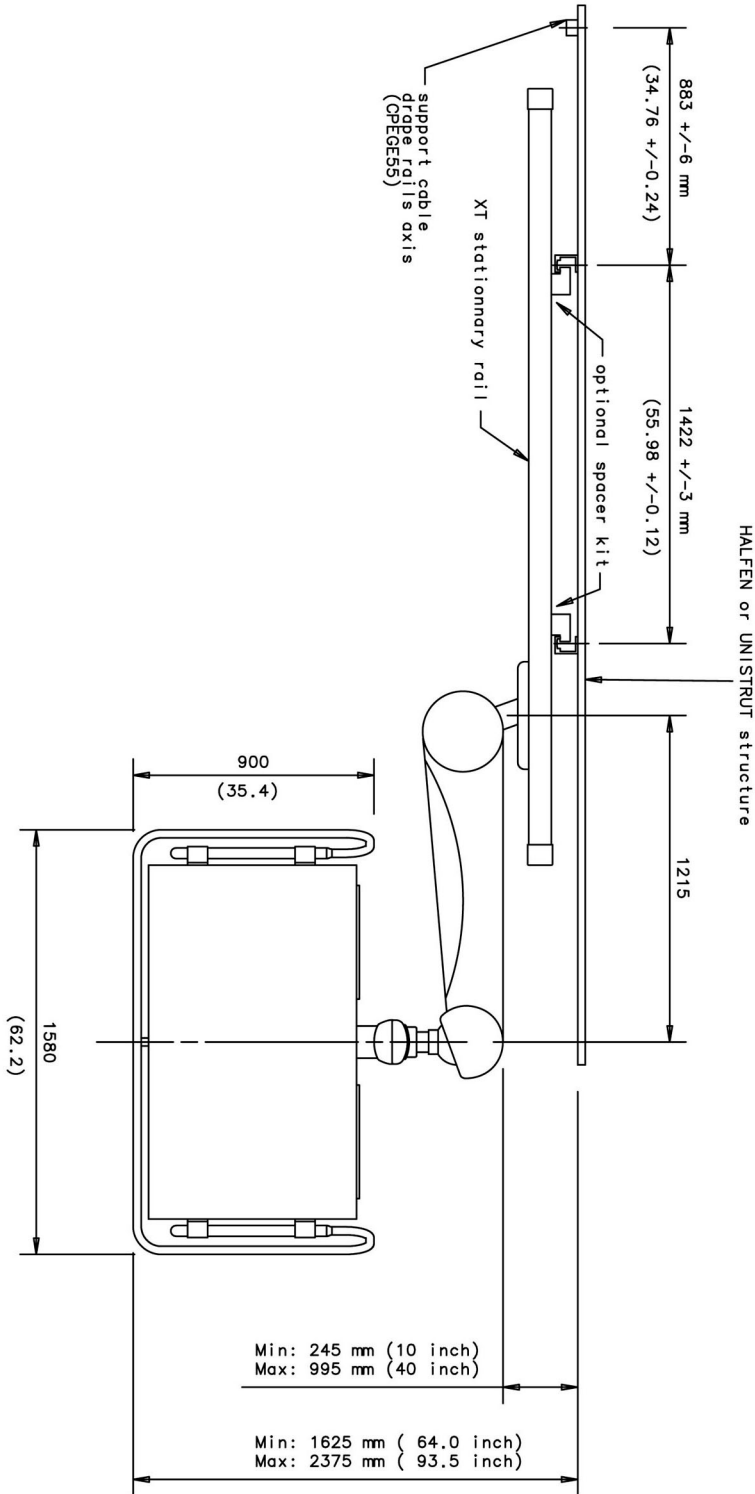

Figure 56 Large display Mavig suspension with fixed point dual arm dimensions (Optional)

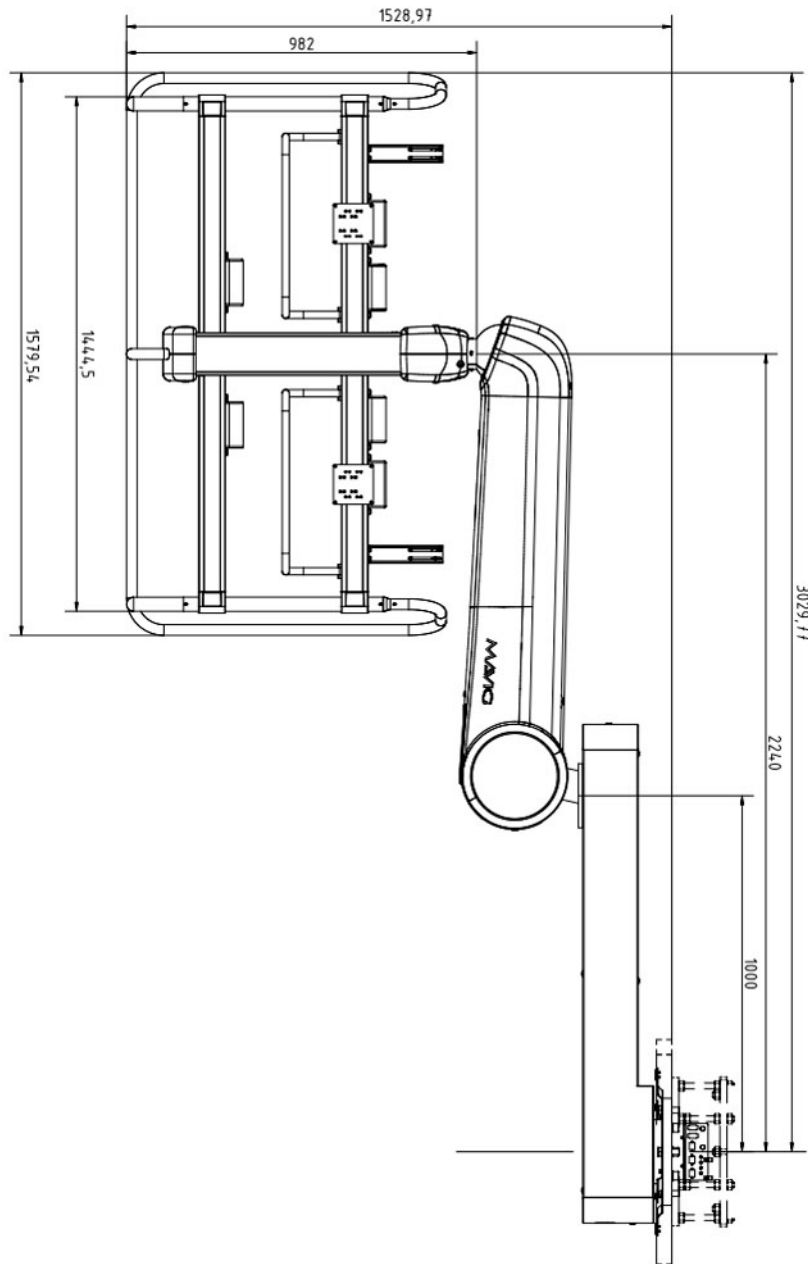
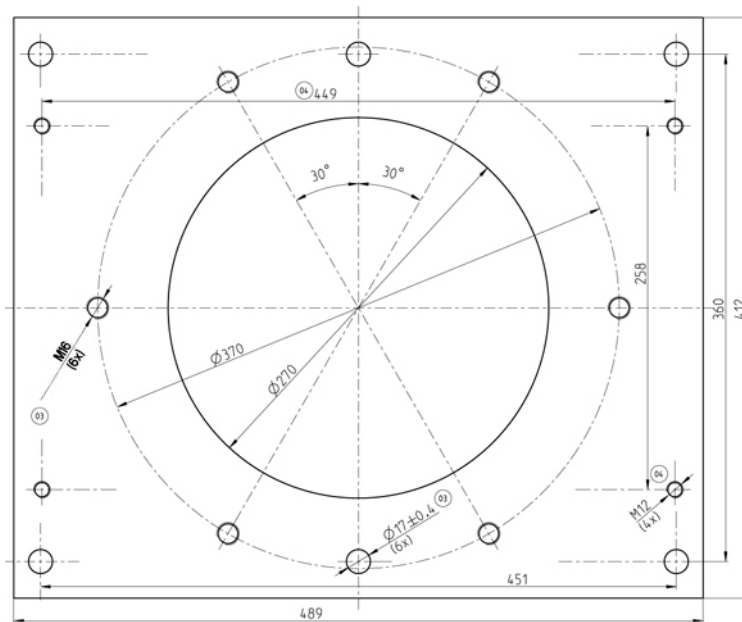

Figure 57 Ceiling Plate of Substructure for Dual Arm suspension dimensions



## 2.2 Room Layouts

### 2.2.1 Room Dimension Requirements

Table 12 Exam Room dimensions

	Length m (ft)	Width m (ft)	Ceiling Height m (ft)
Recommended	9.75 (32)	6 (20)	3.05 (10)
Minimum	Minimum room length depends on the type of Patient Table, refer to Table 13 on page 70, Table 14 on page 70 and Table 15 on page 70	4.40 (14.5)	2.74 (9)

For the tables below, refer to [Figure 58 on page 71](#).

For Head Extender Dimensional drawing, refer to [2.1.3 Dimension Drawings on page 42](#).

#### NOTE

With a Mavig suspension with fixed point dual arm for Large Display Monitor, the minimum ceiling height can be reduced down to 2.71 m (8.9 ft).

**Table 13 Minimum Exam Room length with Omega IV Table**

Configuration	Minimum Room length <b>A</b> mm (in)	
	without Head Extender	with Head Extender <b>F</b>
Cardio 1395 mm (54.9 in) <b>E</b>	5470 (215.3)	5470 (215.3)

**Table 14 Minimum Exam Room length with Omega V Table**

Configuration	Minimum Room length <b>A</b> mm (in)	
	without Head Extender	with Head Extender <b>F</b>
Angio 1278 mm (50.3 in) <b>C</b>	6036 (237.6)	6036 (237.6) + 150 (6)
Cardio and Neuro 1395 mm (54,9 in) <b>E</b>	6036 (237.6)	6036 (237.6) + 150 (6)

**Table 15 Minimum Exam Room length with Innova<sup>IQ</sup> and Innova<sup>IQ</sup> OR Table**

Configuration	Minimum Room length <b>A</b> mm (in)	
	without Head Extender	with Head Extender <b>F</b>
Angio 1278 mm (50.3 in) <b>C</b>	6136 (241.6)	6136 (241.6) + 150 (6)
Neuro 1395 mm (54,9 in) <b>D</b>	6136 (241.6)	6136 (241.6) + 150 (6)

Figure 58 Minimum Room Length Dimension

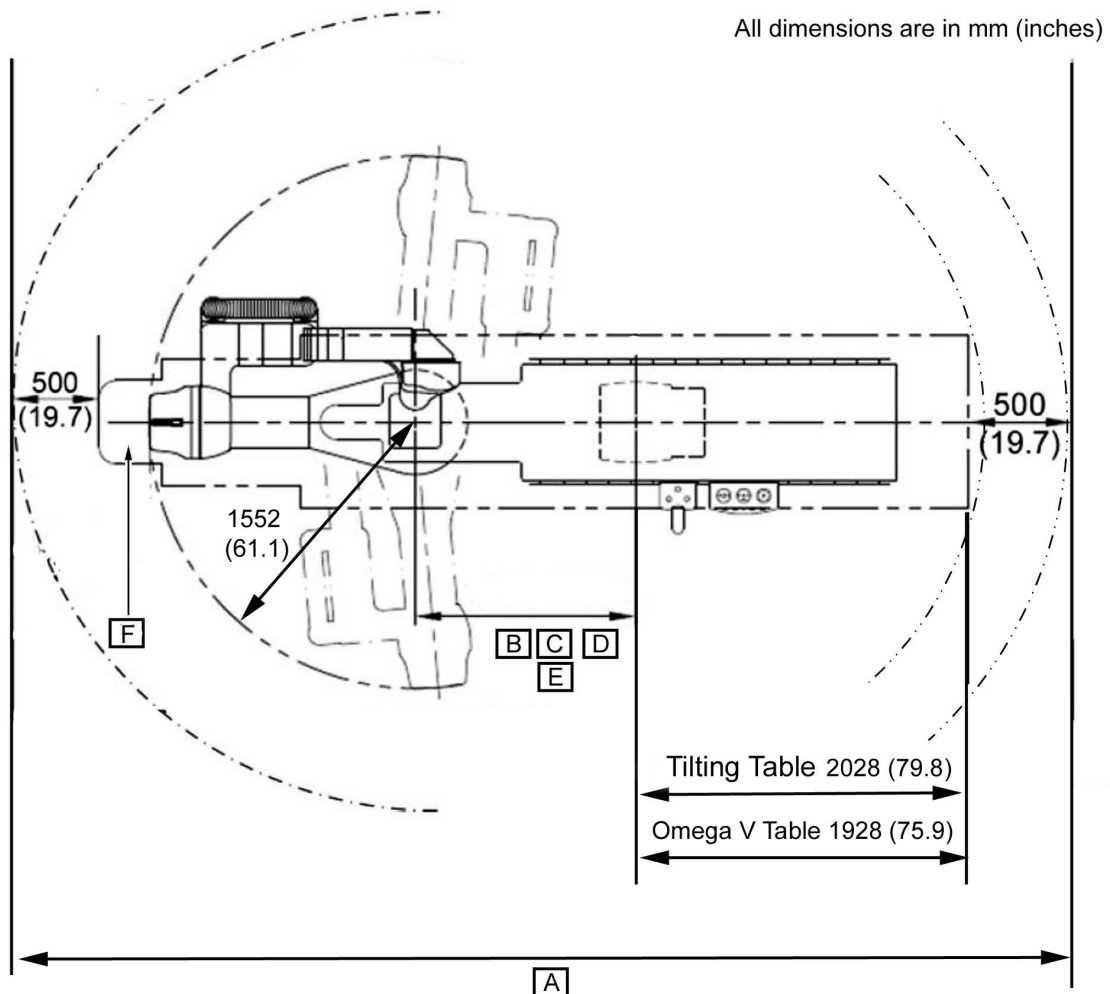

## 2.2.2 Room Layout Drawings

### 2.2.2.1 Exam Room Layout



#### NOTICE

Ensure the air outlet positions in the Exam Room is not close to the monitor suspension carriage or rail.

Legend of Figure 59 on page 72, Figure 60 on page 73, Figure 61 on page 74 Figure 62 on page 75 and Figure 63 on page 76:

1. Gantry
2. Patient Table
3. Monitor suspension

- 4. Monitor frame
- 5. Injector on pedestal

Figure 59 Exam Room Layout - Monitor suspensions rails parallel to patient table (to side of table)

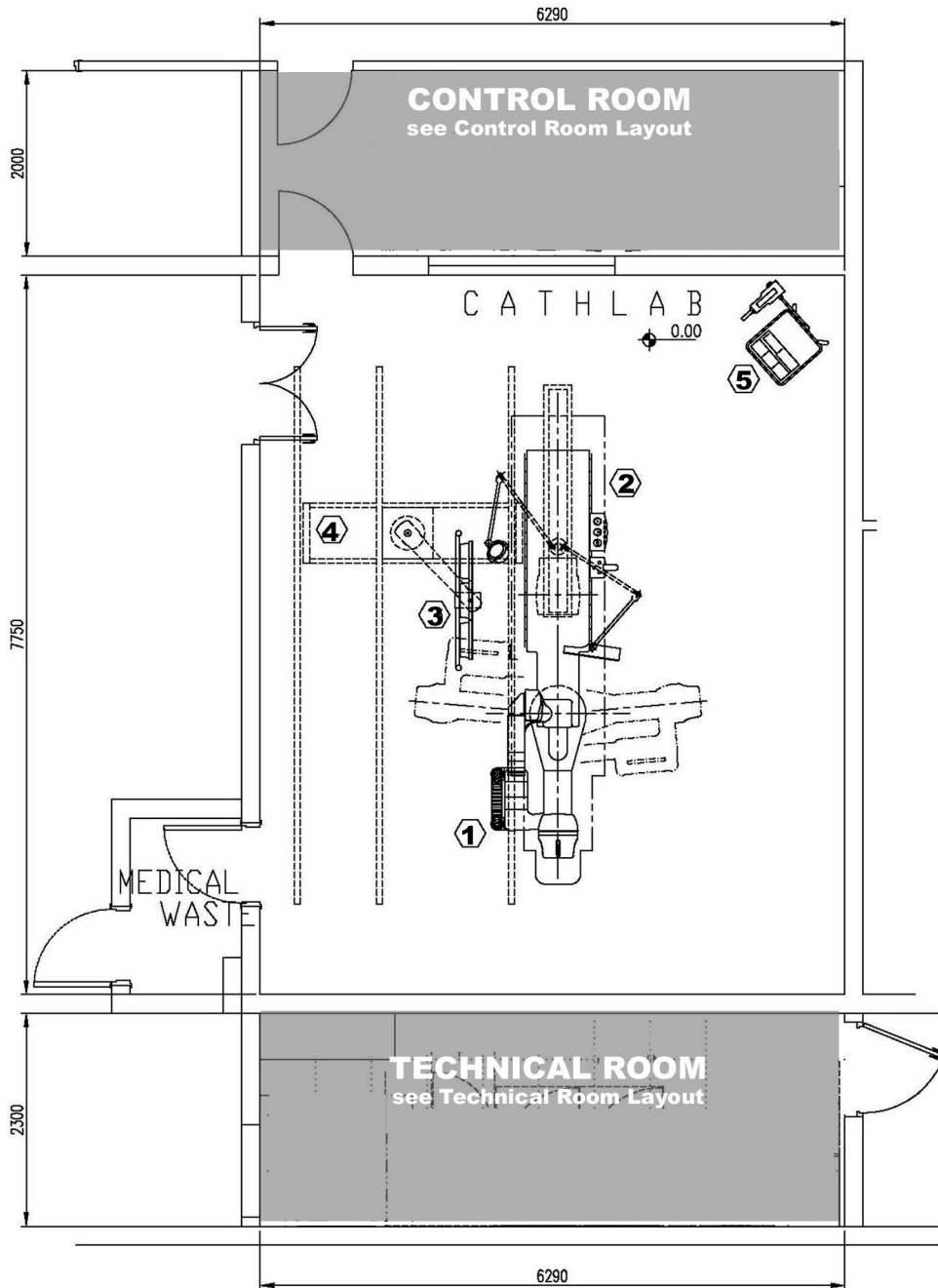

Figure 59 on page 72 is mandatory with hospital having air flow installation.

Figure 60 Exam Room Layout - Monitor suspensions rails parallel to patient table (over table)

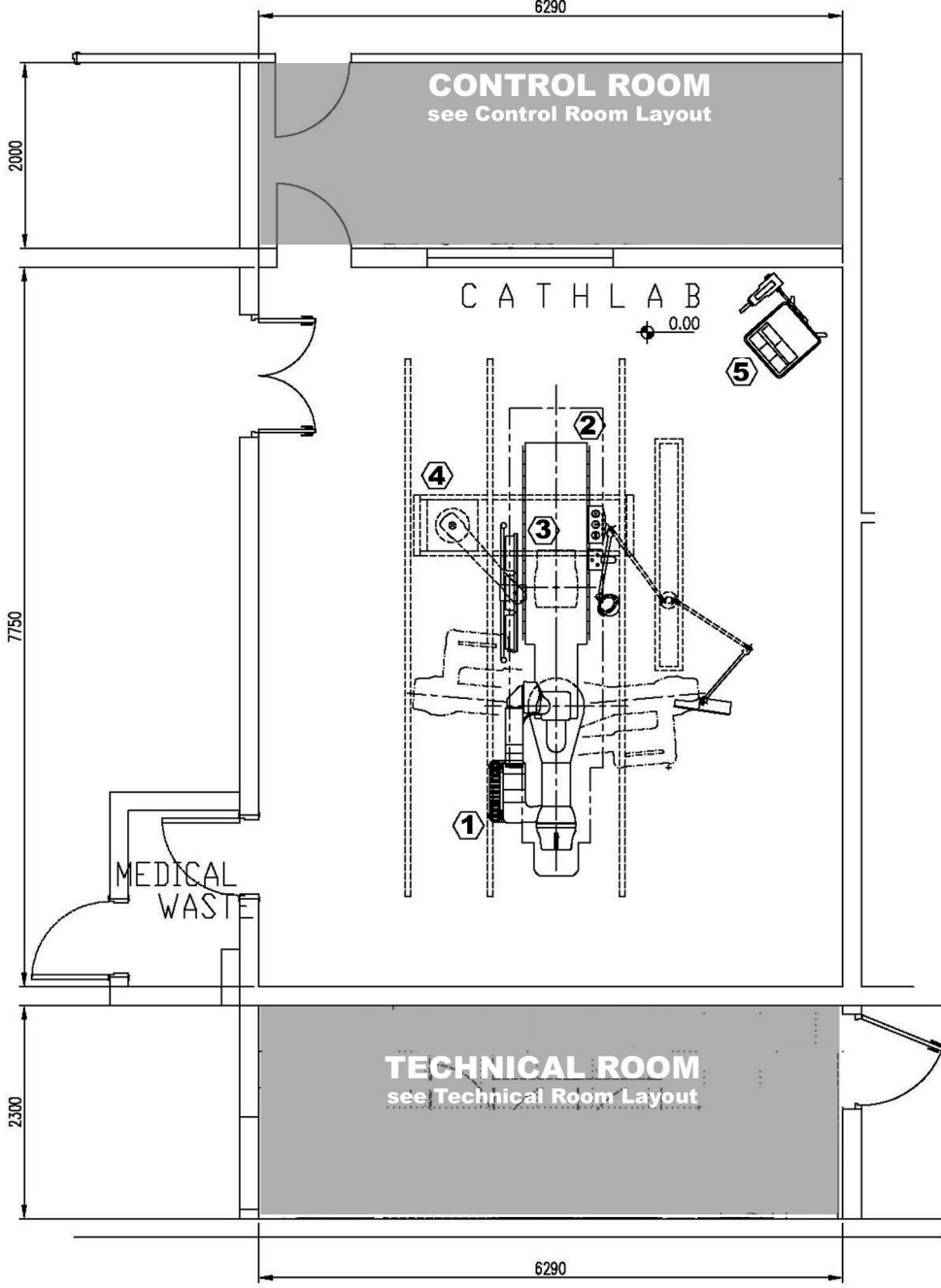

Figure 61 Exam Room Layout - Monitor suspensions rails perpendicular to patient table (Gantry side)

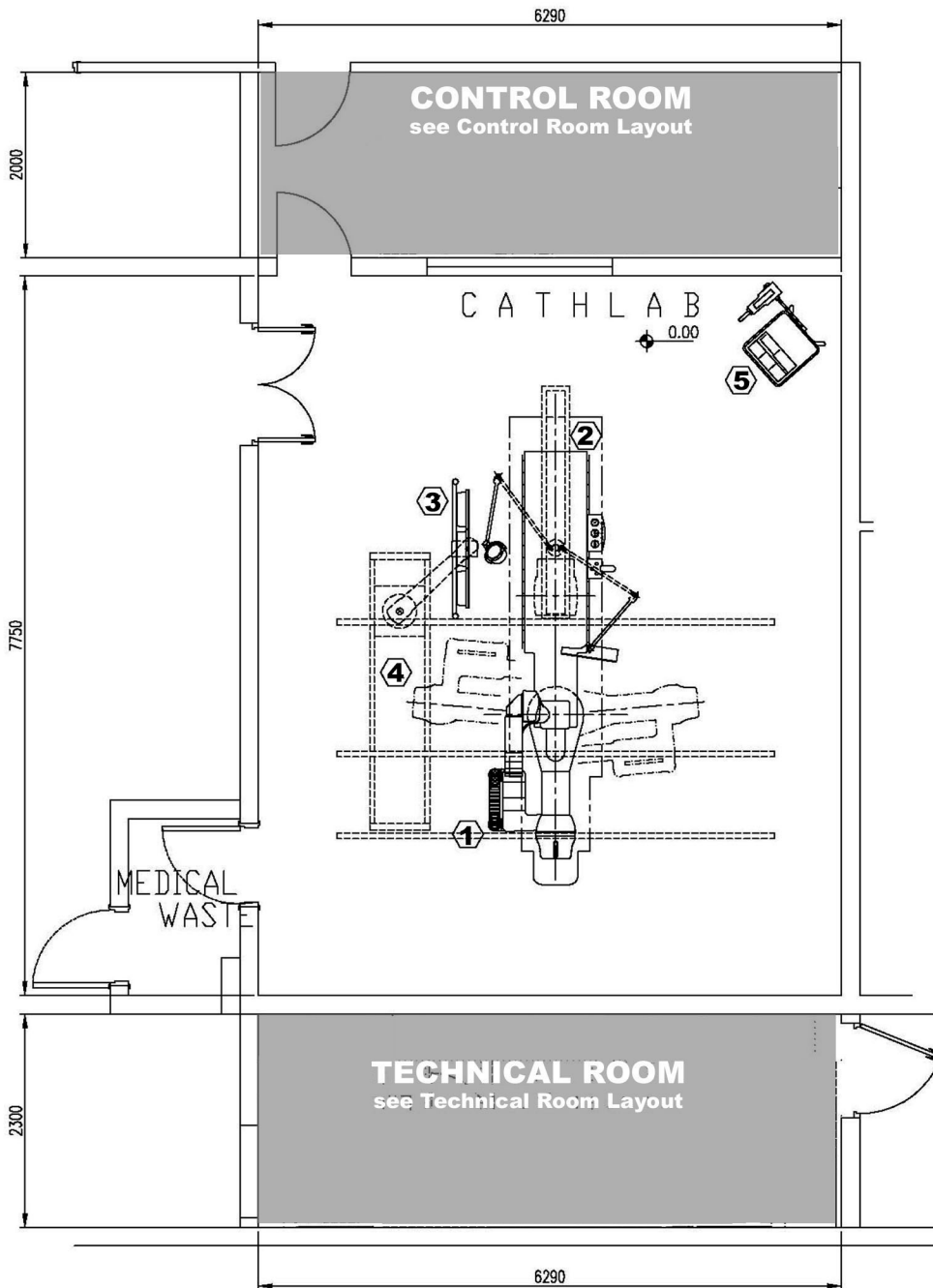
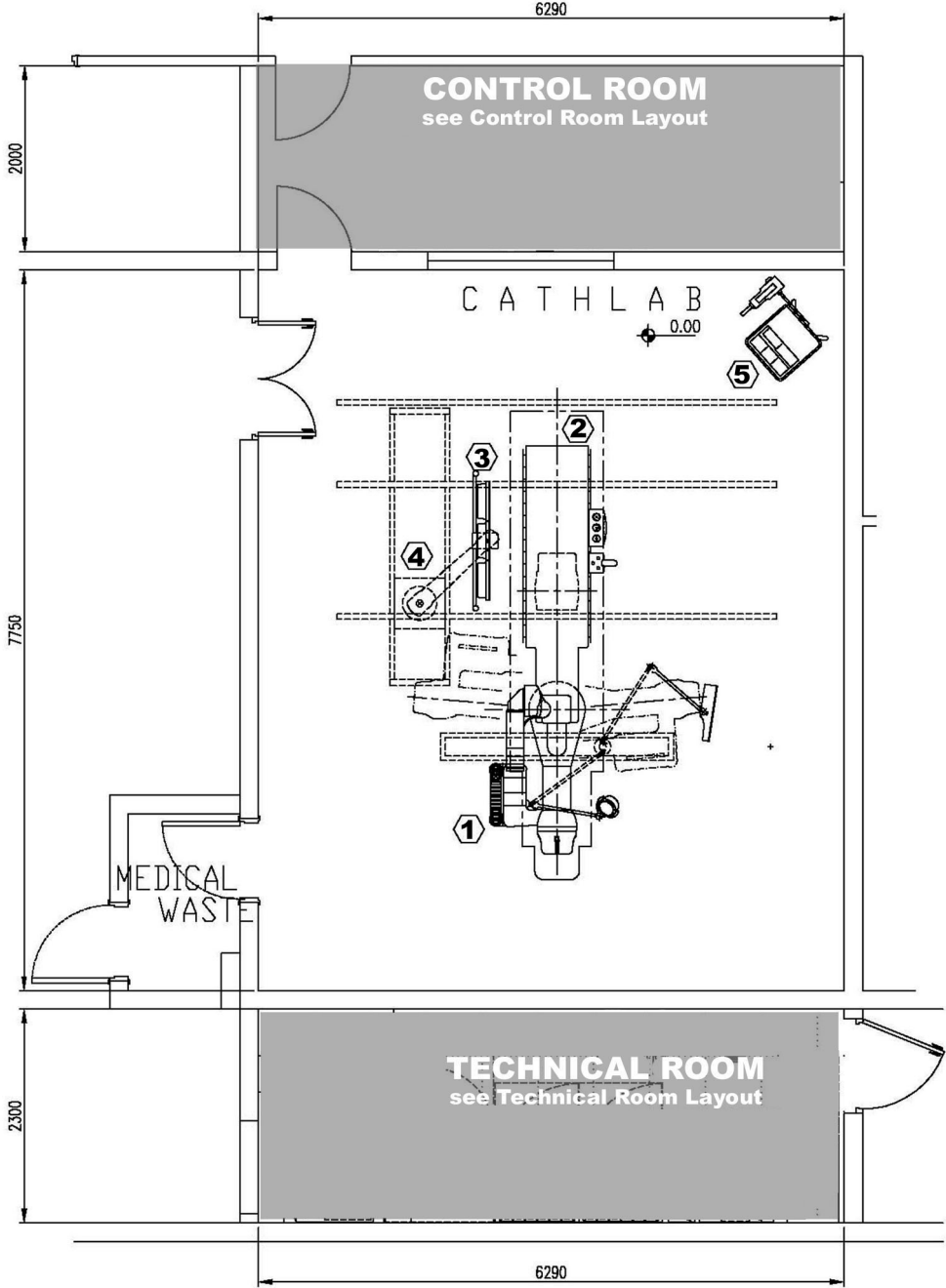
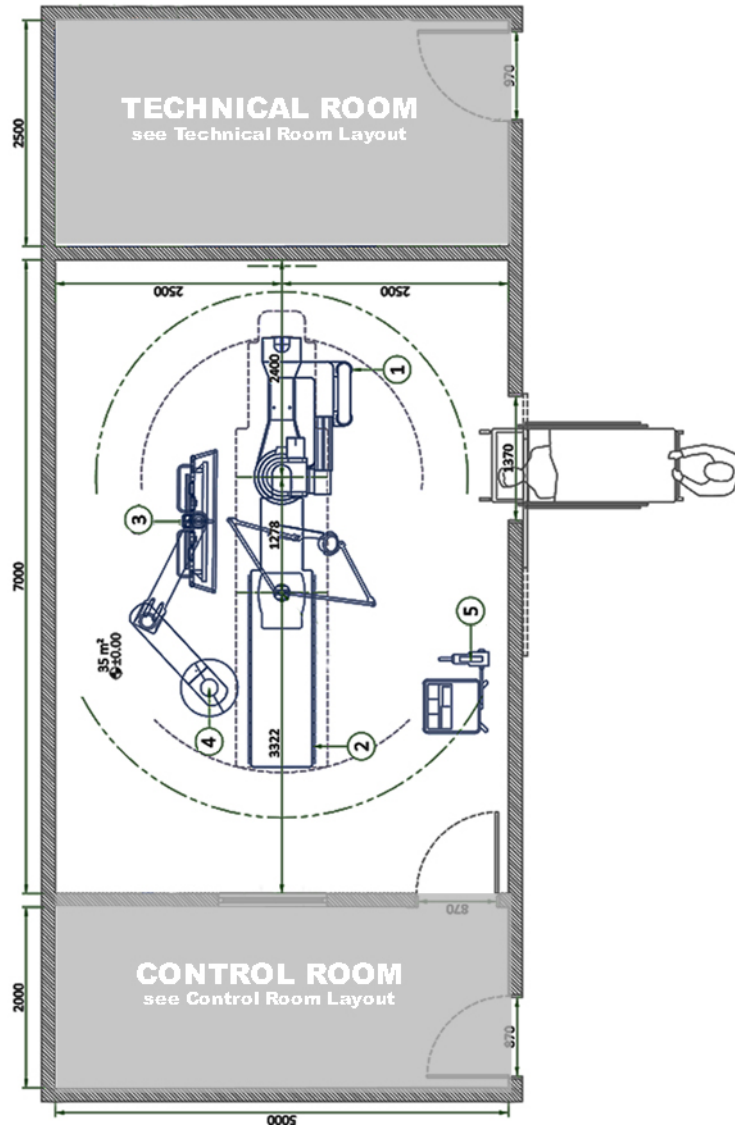

Figure 62 Exam Room Layout - Monitor suspensions rails perpendicular to patient table (table side)



**Figure 63 Exam Room Layout - MAVIG suspension with fixed point with dual arm for Large Display Monitor**



**NOTE**

The suspension ceiling fixation shall be determined taking into account at least:

- Clinical need: with an overall radius coverage of 2.03 m, ensure the monitor will be able to reach the position required by medical staff.
- Parking position.
- Ceiling constraints: other component and air flow.
- Cable output and ceiling trap.

### 2.2.2.2 Control Room Layout

Motion controls installed in remote location from the Table shall be installed at a location where all the positioner axis are visible by the operator.

In case the system has an Innova<sup>IQ</sup> Table or an Innova<sup>IQ</sup> OR Table, the remote motion controls shall not be installed on the longitudinal axis of the Table (to avoid any operator visual dead angle due to tilted table top hiding the patient).

Figure 64 Control Room Layout

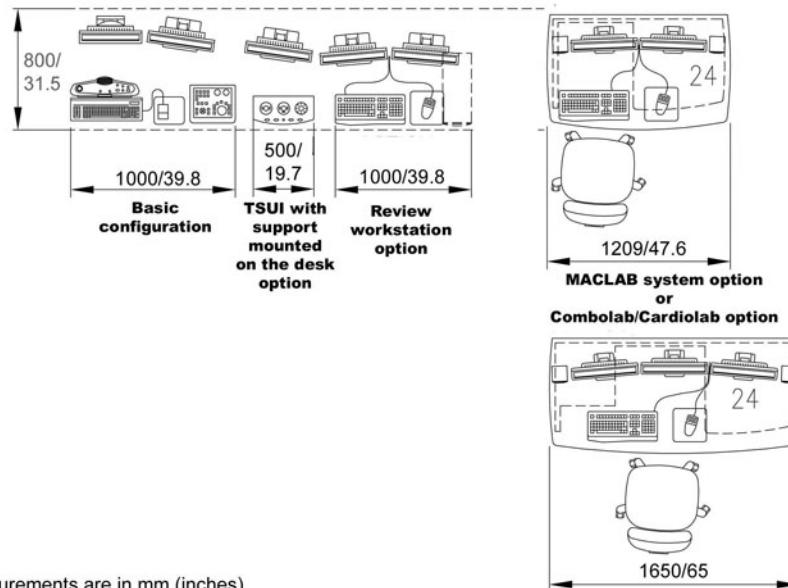
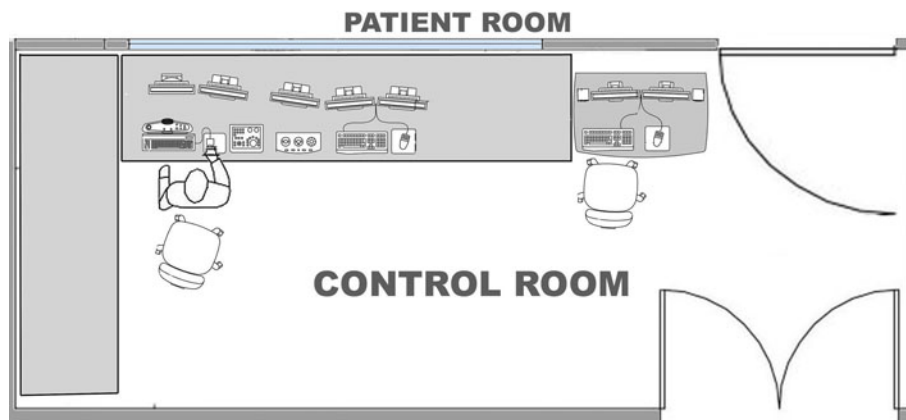

All measurements are in mm (inches)

### 2.2.2.3 Technical Room Layout



Condensation may occur on the outlets and pipes of the air conditioning system, therefore, it is critical to install the cabinets where there is no risk of water drops from the air conditioner.

#### 2.2.2.3.1 General Requirements

It is not allowed to store objects on cabinet top, or to stack cabinets one on another.

In cases 2 cabinets are installed face to face (both sides of the access way), the clearance width shall be at least 1.2 m.

In order to maintain their cooling capacities:

- The Tube Chiller shall be no more than 5 m (16 feet) above or 8 m (26 feet) below the upper position of the X-Ray Tube.

**Figure 65 Distance between Tube Chiller and X-Ray Tube**

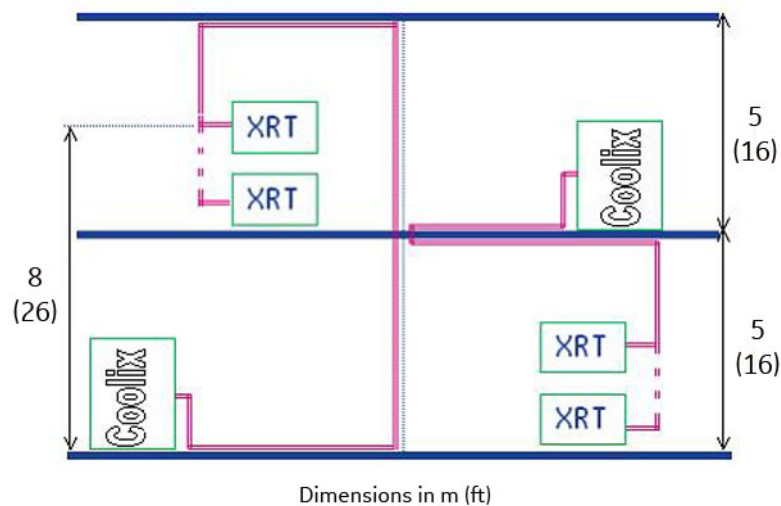

**NOTE**

The highest point of the water network can be 10 m (32 feet) above the floor of the Technical Room where the Coolix-4100 is located (case where the Technical Room is one floor under the Exam Room).

- The Detector Conditioner shall be no more than 3 m in height below the Detector.

It is the customer responsibility to install a fire extinguisher (non-water type, ex. CO2) close to the Fluoro UPS CE Cabinet.

Figure 66 Technical Room Layout - Configuration 1 kVA UPS

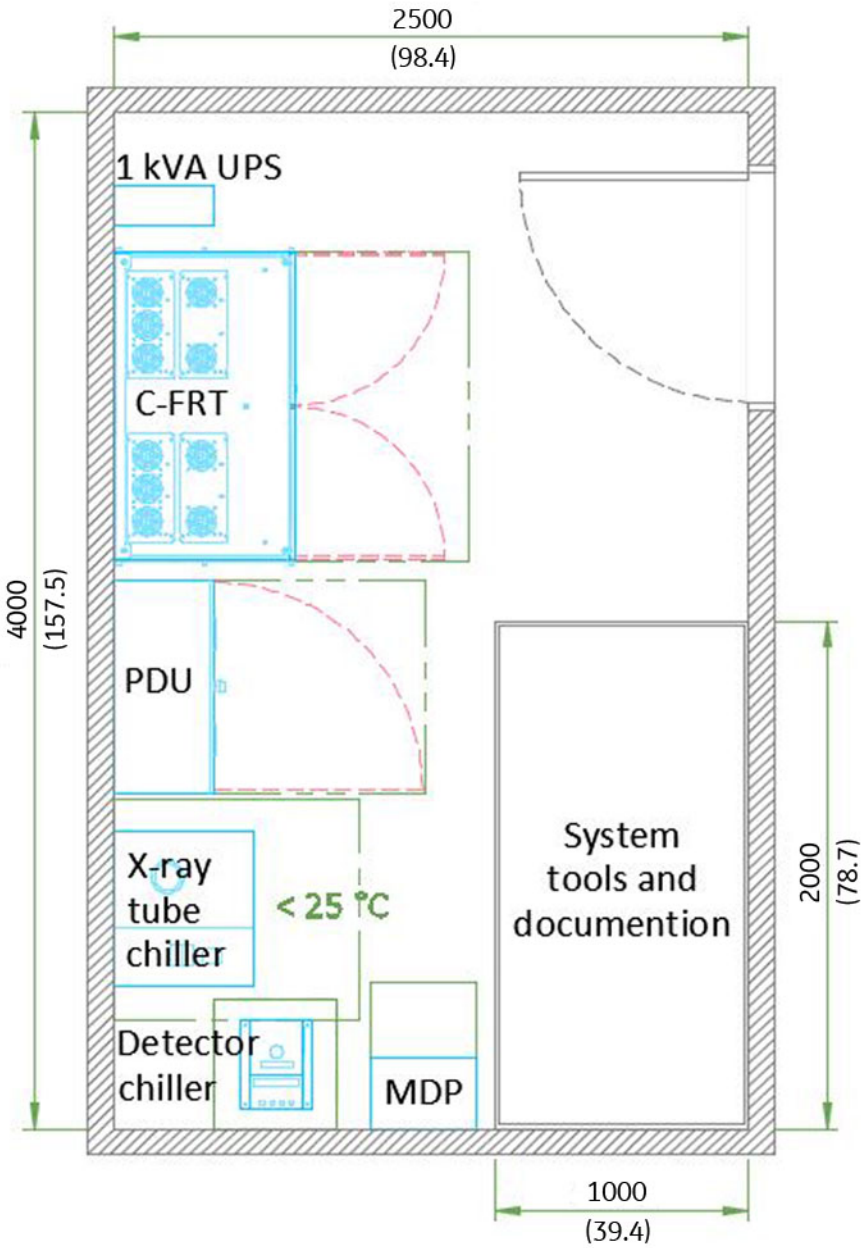

Dimensions in mm (in)

Figure 67 Technical Room Layout - Configuration 8 kVA UPS

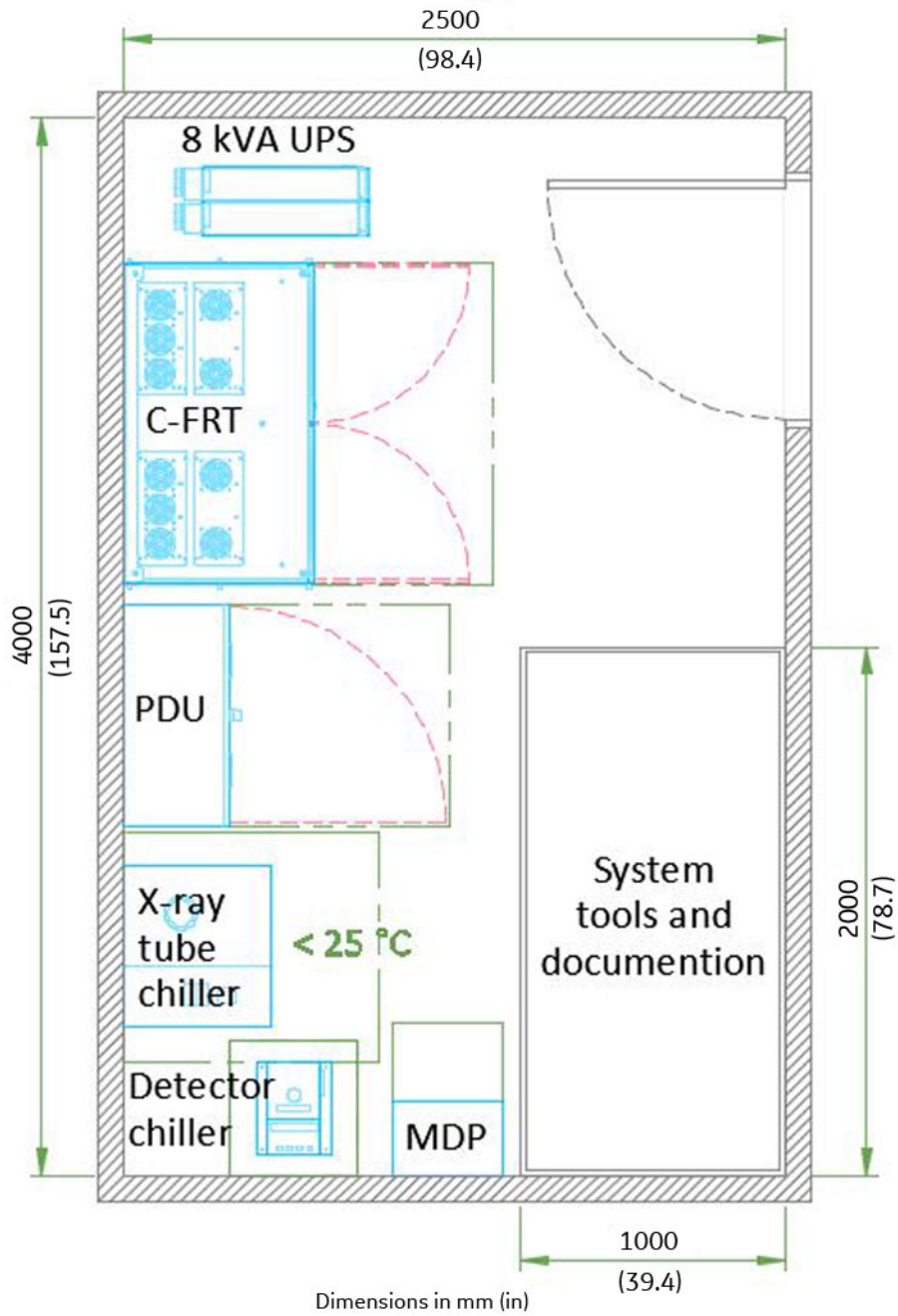
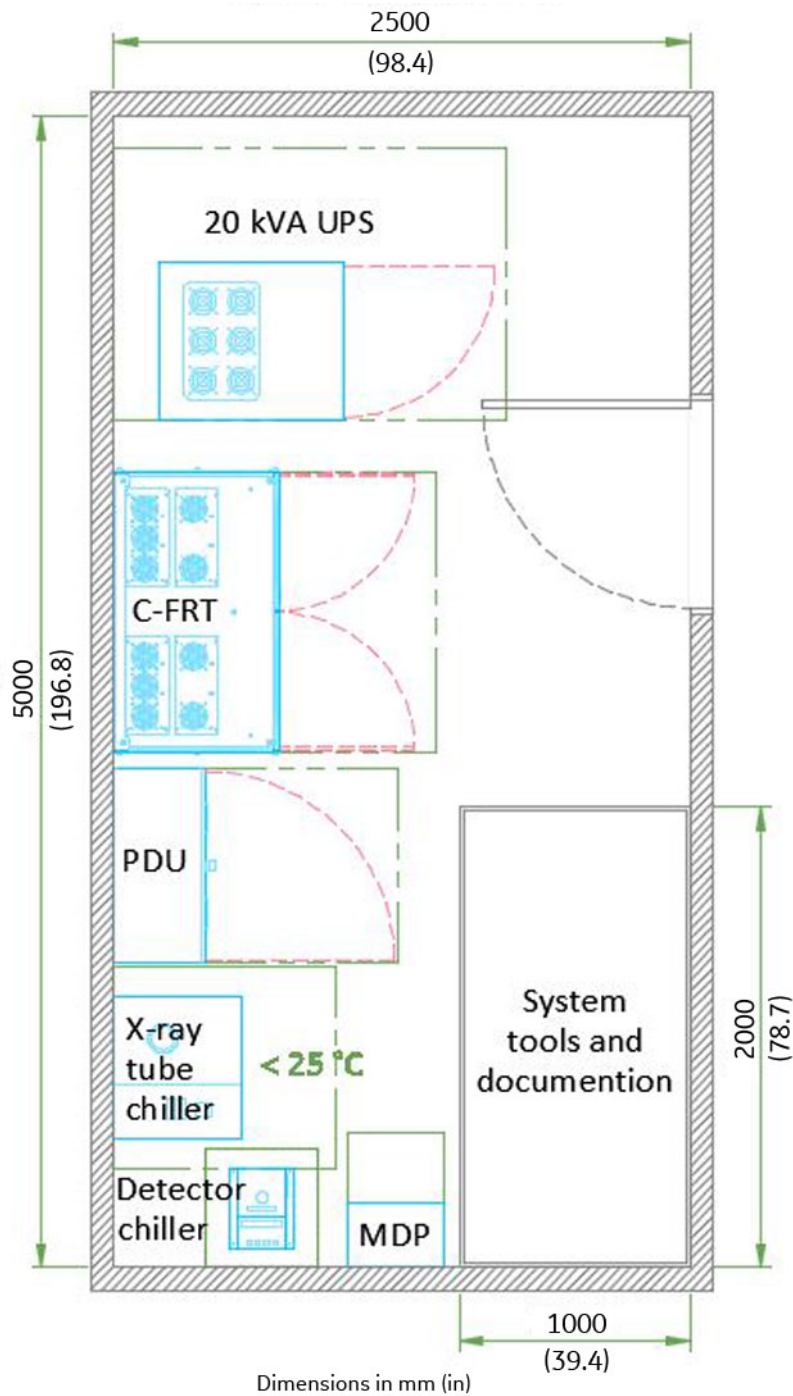

Figure 68 Technical Room Layout - Configuration 20 kVA UPS (Fluoro UPS)



### 2.2.2.3.2 Electromagnetic Requirements

The Detector inside the Gantry (in all its positions) shall be more than 1 meter from the front of the C-FRT Cabinet to minimize low frequency magnetic field interference risks.

### 2.2.2.3.3 Requirements for Service Access and Equipment Airflow

For the service access see [2.2.3 Room Layout Considerations on page 84](#).

If the Technical Room is in a dusty environment, it is strongly recommended to install filters on the air inlet of the Technical Room. These filters can cause reduced speed at the air inlet, and the size of the air inlet has therefore to be dimensioned accordingly.

The following distances shall be respected to guarantee proper cooling air exhaust.

C-FRT Cabinet:

- The minimum clearance between the ceiling and the top of the C-FRT Cabinet is 30 cm (11.8 in).

NPA PDU:

- The minimum clearance between the ceiling and the top of the NPA PDU is 30 cm (11.8 in).

Tube Chiller:

- The Chiller can operate normally when installed against a wall or another cabinet (no possible air flow) on 1 side. The following clearance must be respected: back and one side: 40 cm minimum, front: 13 cm.
- Minimum 40 cm is needed for servicing on the left and right side panel.

Detector Conditioner:

- The following 50 cm clearance on the sides must be respected.

**Figure 69 Detector Conditioner – Minimum clearance**

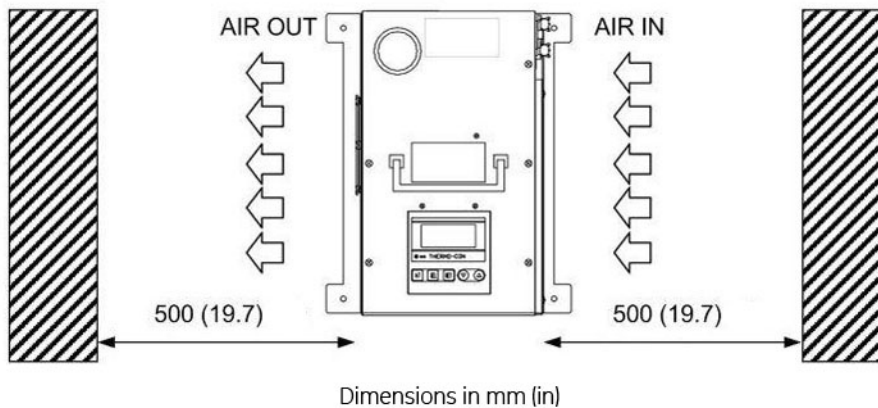

Fluoro UPS:

- The minimum clearance between the ceiling and the top of the UPS is 40 cm.
- UL version: the left, right or back side of the UPS can be positioned against the wall or another cabinet.
- CE version: a clearance of 20 cm between the UPS back and the wall must be respected. A clearance of 50 cm is needed on the right side of the UPS cabinet for service.

- Make sure there is a ventilation air flow, preferably ensured by natural air flow, otherwise by enforced ventilation, so that hydrogen concentration is below 1% (according to the Standard IEC 62040-1-2).

## 2.2.2.4 ECG Device Room Configurations

The ECG connection is compatible with an ECG in the Control Room or in the Exam Room.

The Analog Output Box option is mandatory to provide an analog output connection to the Physio module (If not present, it can be ordered through the following FRUs):

- 2018971-001 16CH ANALOG OUTPUT CPU INTERFACE OPTION
- 2007557-002 KIT ANALOG OUTPUT BOX W/CABLES
- 2010476-001 BOX CARDIOLAB/MACLAB ANALOG OUTPUT

### 2.2.2.4.1 ECG in Control Room

Applicable to GE ECG as MacLab, CardioLab or ComboLab.

In this configuration, the Physio module and the Hubican module are installed in the Control Room.

Figure 70 ECG in Control Room - Connection

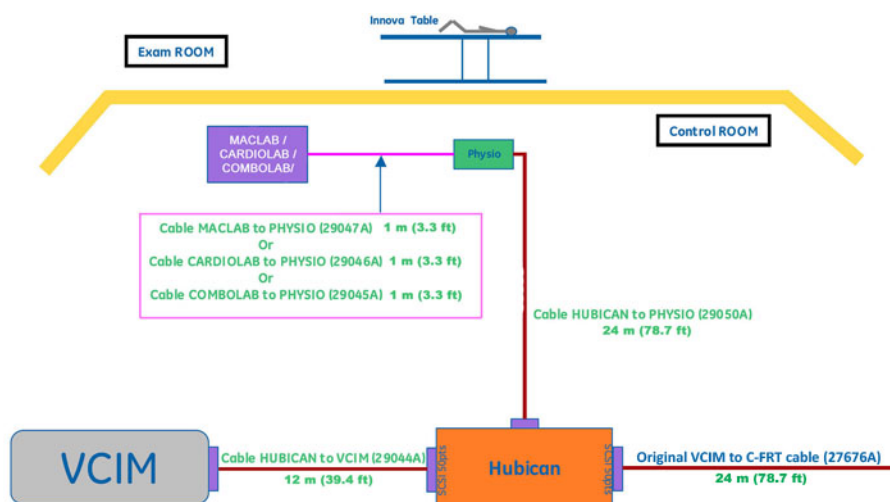

### 2.2.2.4.2 ECG in Exam Room

In this configuration, the Physio module is in the Exam Room and the Hubican module is installed in the Control Room.

Figure 71 ECG in Exam Room - Connection

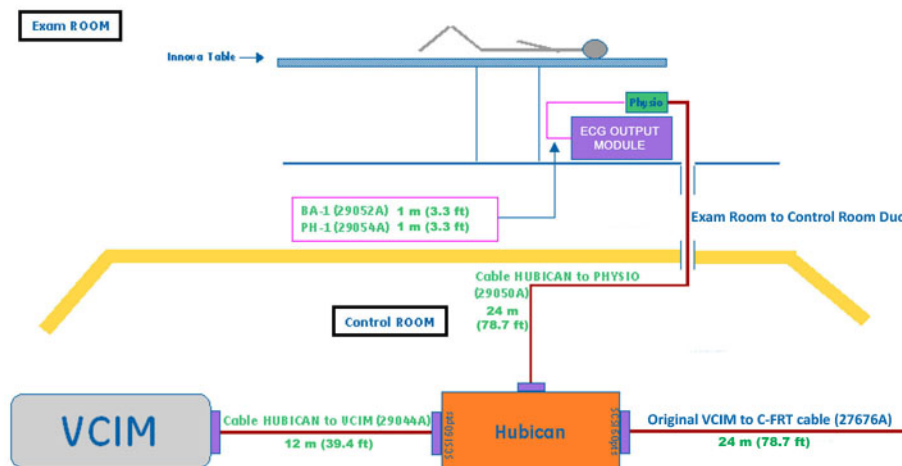

## 2.2.3 Room Layout Considerations

### 2.2.3.1 Radiation Protection

Because X-Ray equipment produces radiation, you may need to take special precautions or make special site modifications. The General Electric Company does not make recommendations regarding radiation protection. It is the purchasers' responsibility to consult a radiation physicist for advise on radiation protection in x-ray rooms.

### 2.2.3.2 Service Access

Allow appropriate space for service access of equipment. Consult component pre-installation directions for clearance information.

### 2.2.3.3 Clinical Access

Make sure that you plan the room with the following clinical access requirements:

- Provide easy access to the patient table. Stretchers and other mobile hospital equipment must reach the table quickly.
- The layout of the table in the room (PIM) shall make a provision so that the clearance between the maximum table position (head side) on system axis and any object in the room (e.g.: wall, device) be greater than 50 cm (19.7 in) or 65 cm (25.6 in) if the Header Extender is used), taking into account the fact that the Innova<sup>IQ</sup> and Innova<sup>IQ</sup> OR Table can rotate 180°.
- Provide sufficient space around the patient table for the unimpeded conduct of CPR (Cardiac Pulmonary Resuscitation). With the table in this position, the table must be capable of rotating ± 45°
- Clinicians at the patient table must be able to communicate with assistants in the control area.
- There must be an unrestricted view of the video monitors and physiological monitoring equipment from the vascular table.

- Operators in the control area must have easy access to the control console. However, position the controls (including handswitches) so that the operator cannot take exposures while looking around or standing outside the control booth's lead glass window.
- Operators in the control area must have easy access to video recorders, injector programmers, and service and operating manuals.
- Consult customer on the number and location of nonelectrical lines (air, oxygen, vacuum, water, etc.) in the vascular room.
- For systems with the LDM, make sure the backup monitors are easily accessible to view in case of failure of the LDM. For the systems where the backup monitors are mounted at the back of the LDM, plan a clearance so that the monitor can be flipped at 180°.

#### **2.2.3.4 Peripheral Equipment**

Consult hospital personnel regarding additional space requirements for the following types of hospital equipment:

- Sinks
- Oxygen stations
- IV apparatus
- Injectors
- Heart monitoring equipment
- Crash cart
- Ultrasound equipment.

#### **2.2.3.5 Emergency Stop**

Protect the Emergency Stop from accidental actuation.

#### **2.2.3.6 Patient Environment Equipment**

As defined in the IEC60601-1, the patient vicinity is defined as the space within the room 1.83 m (70.7") beyond the perimeter of the table and extending vertically 2.29 m (90.2") above the floor. Only the following components of the system can be installed within the patient vicinity:

- Table and its accessories
- Monitors
- Injector
- Rad-Shield
- Table Side User Interfaces
- In-room AW mouse.

## 2.3 Room Structural Requirements

### 2.3.1 General Policy

#### 2.3.1.1 Baseplates Mounting

GE Healthcare's Customer is responsible for the structural analysis and mounting of the base plates. If GE Healthcare is forced to mount the base plate, the LCT must hire a structural engineer to design and approve the mounting method and provide GE Healthcare with an engineering report.

The floor level cannot exceed a general levelness of 5 mm (0.2 in) for any 2 meters (79 in).



#### NOTICE

The floor slabs on which the equipment is to be installed must have a levelness of 1 mm (0.04 in) per meter (40 in). Position of baseplates and table basement depends on the type of installation. The two types of installation are given below.

Figure 72 Types of baseplate installation

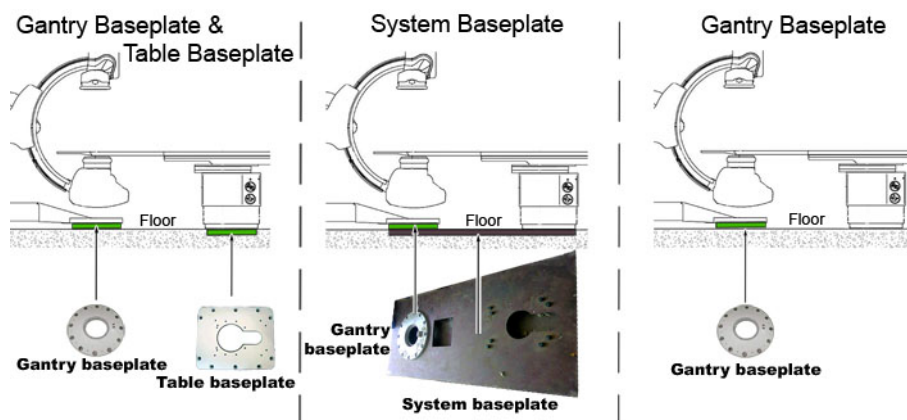

#### NOTICE

The Table baseplate or the System baseplate are mandatory to install the Innova<sup>IQ</sup> and Innova<sup>IQ</sup> OR Table.

The Innova<sup>IQ</sup> and Innova<sup>IQ</sup> OR Table must never be installed on grade.



#### NOTICE

Augmented Calibration requires that the patient table and gantry be installed following Pre-installation instructions. Any deviation result in errors raised during calibration.

**NOTICE**

The gap between the Table Foot bottom end the Gantry Baseplate bottom end shall be lower than 20 mm (0.97 in). Any bigger gap would make the system incompatible with the Innova Vision Applications.

**Figure 73 Gap between Table Foot bottom end the Gantry Baseplate bottom**

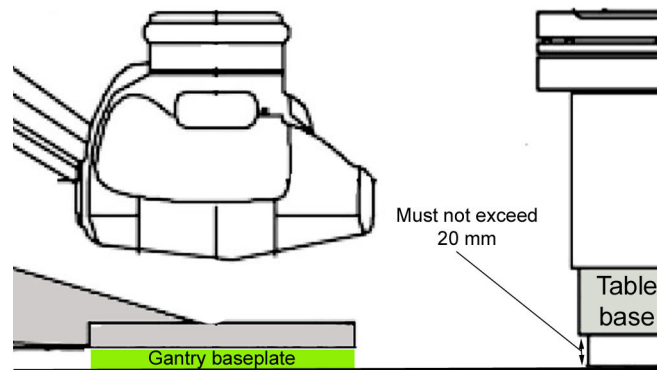

The preferred installation method for the Innova LC Positioner or the Omega tables is through-bolting. The through-bolting method can be used in all seismic zones. If through-bolting cannot be used, use provided floor anchors instead.

**Figure 74 Through-Bolt Supplied (Slab Type Floor Construction)**

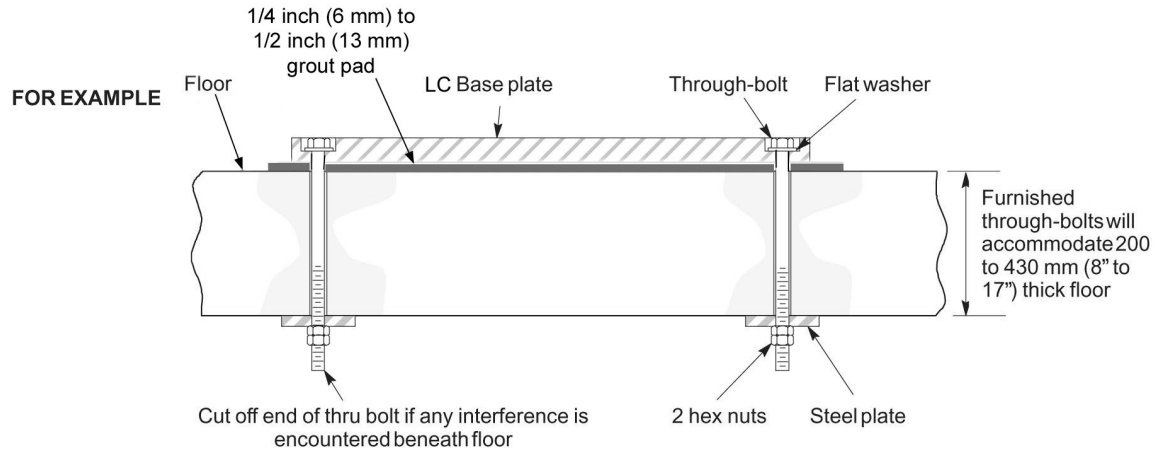

### 2.3.1.2 Substructure for Dual Arm suspension Mounting (for Mavig suspension with fixed point dual arm for Large Display Monitor)

The customer is responsible for the structural analysis and mounting of the Substructure for Dual Arm suspension in the solid ceiling (in case of a Large Display Monitor and the MAVIG suspension with fixed point dual arm). If customer requires GEHC to mount the Substructure for Dual Arm suspension, the customer must hire a structural engineer to design and approve the mounting method and provide GEHC with an engineering report.

**Figure 75 Medium Height Substructure for Dual Arm Suspension and MAVIG Suspension with Fixed Point Dual Arm**

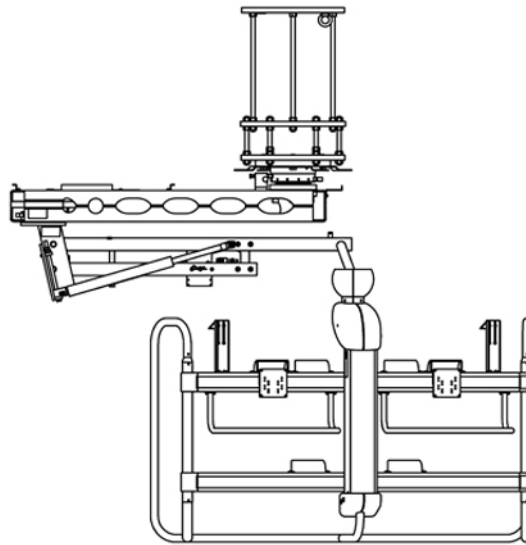

**NOTICE**

The Substructure for Dual Arm suspension is mandatory to install the MAVIG suspension with fixed point dual arm.

**NOTICE**

The lower edge of the Substructure for Dual Arm suspension should be the same height as the lower edge of the false ceiling.

## 2.3.2 Floor Requirements

### 2.3.2.1 Floor requirements when using provided floor anchors

The maximum pullout force per provided anchor was calculated assuming:

- A concrete compression strength of **17.24 MPa** at 28 days (which is the minimum required compression strength).
- Anchors installed to the required hole depth of **165.1 mm** minimum, and
- Center of anchor hole to concrete edge distance **79.4 mm**.

Make sure to obtain data on compression strength of the concrete before using floor anchors.

### 2.3.2.2 Pan Type Floor Construction Requirement

For Pan type floor construction, steel channels must be designed by a local structural engineer to span floor joists. See [Figure 76 on page 89](#).

**NOTE**

For specific floor preparation procedures, refer to *Pre-Installation Kit Installation Procedures*.

**Figure 76 Through-Bolt Supplied (Pan Type Floor Construction)**

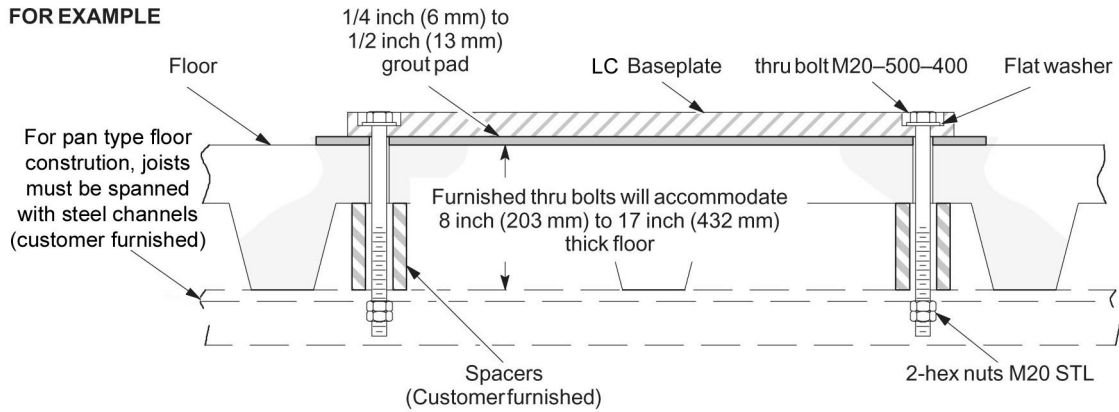

**Figure 77 Table floor mounting layout**

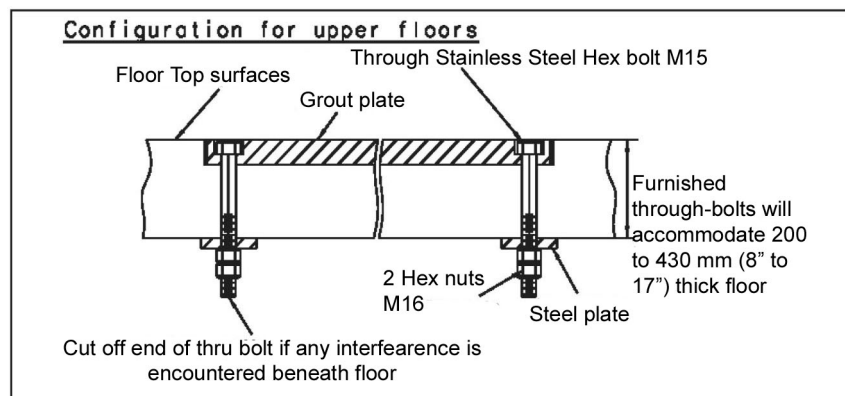
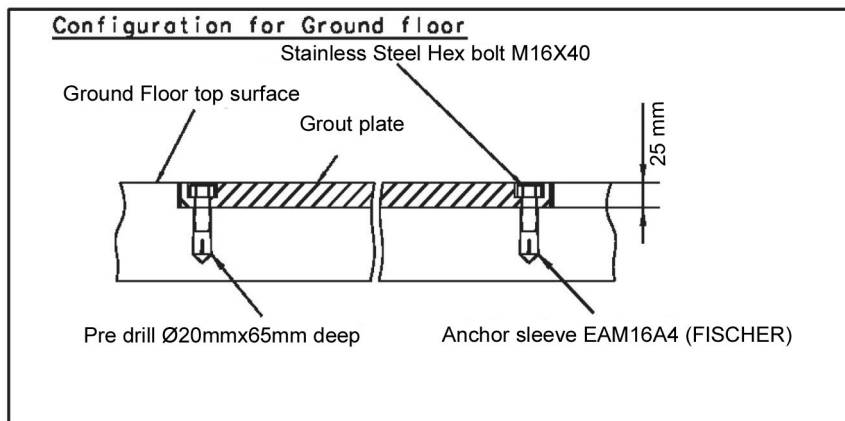



Prepare the floor such that the table base plate will be flush with the floor finish surface, taking into account the thickness of the floor finish material.

For alternative table bolts or seismic area, refer to template drawing shown in Illustration ***Innova LC Positioner And Table Floor Mounting Template*** contained in [2.3.3 Mounting Requirements on page 94](#).

### **2.3.2.3 Hole dimension and preferred location in concrete floor**

In the Exam Room, the Innova LC Positioner is not placed on a computer floor but directly put on concrete floor, the location of the cable access needs to be carefully planned.

Otherwise, if the cable run is located under the concrete floor, the cables will have to come through the floor and in this case you will need two holes, one for the LC Positioner and the other for the patient table.

The diameter of both holes must be the same 225 mm or 9 in.

Figure 78 Hole location in concrete floor

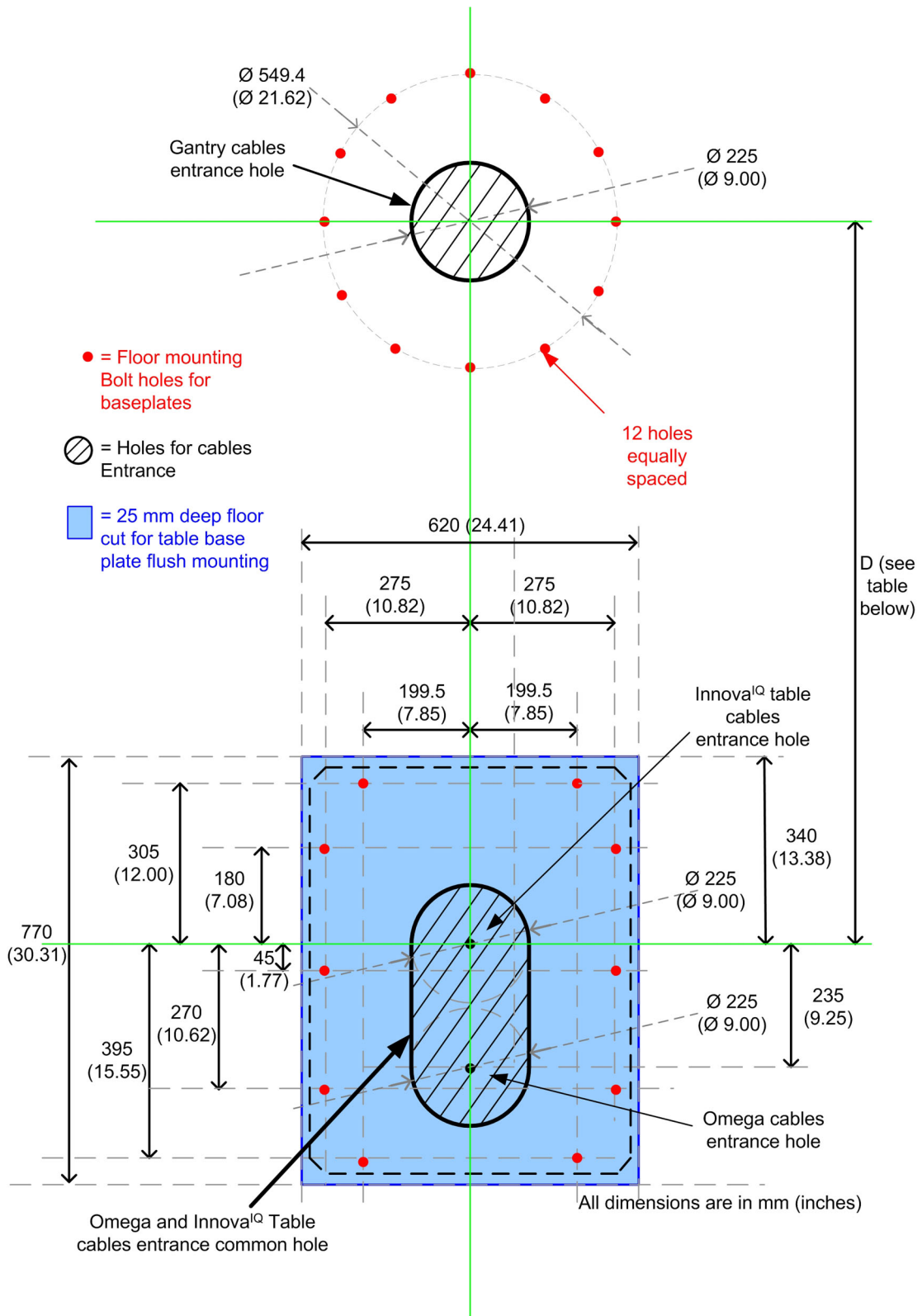

**Table 16 D distance**

	ANGIO mm (in)	CARDIO mm (in)	NEURO mm (in)
Omega IV Compact Table	Not applicable	1395 (54.9)	Not applicable
Omega V Long Table	1278 (50.3)	1395 (54.9)	1395 (54,9)
Innova <sup>IQ</sup> and Innova <sup>IQ</sup> OR Table	1278 (50.3)	1395 (54.9)	Not applicable



**NOTICE**

Due to the plastic bushing used in the USA to protect cables from the sharp edges of conduits it is necessary to place the cable conduit inside the table cable access opening but the height of the outcoming conduit plus bushing is limited to 1/2 in (12.7 mm).

**NOTE**

Refer to table *Chemical anchors Pull out efforts and recommendations* in [2.3.3 Mounting Requirements](#) on page 94 for pull out effort on each fixation bolts.

**2.3.2.4 Water Pipe Requirements**

The system uses 4 water pipes for the cooling of the Tube and the Detector. Local regulation may require that electrical cables and water pipes are ran in separate conduits from the Chillers to the Gantry.

**Figure 79 Water Conduit location with "Above Grade" anchor kits**

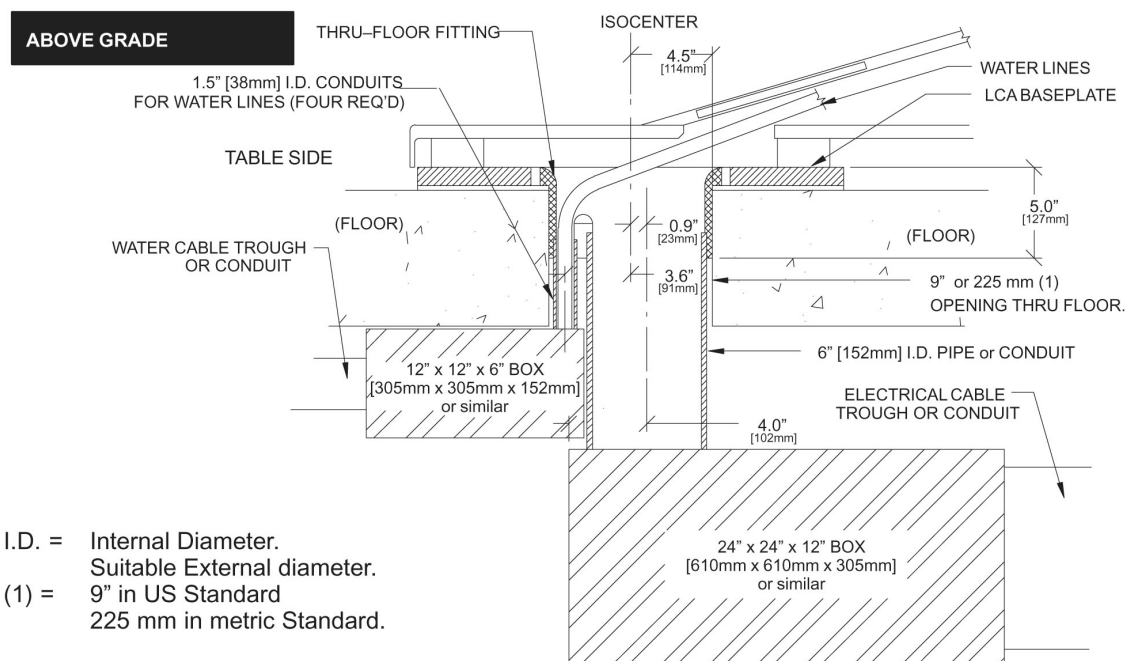

I.D. = Internal Diameter.  
 Suitable External diameter.  
 (1) = 9" in US Standard  
 225 mm in metric Standard.

**Note:** Pipe, junction box and duct or conduit are to be supplied and installed by Customer or customer's Contractor.

Figure 80 Water Conduit location with "On Grade" anchor kits

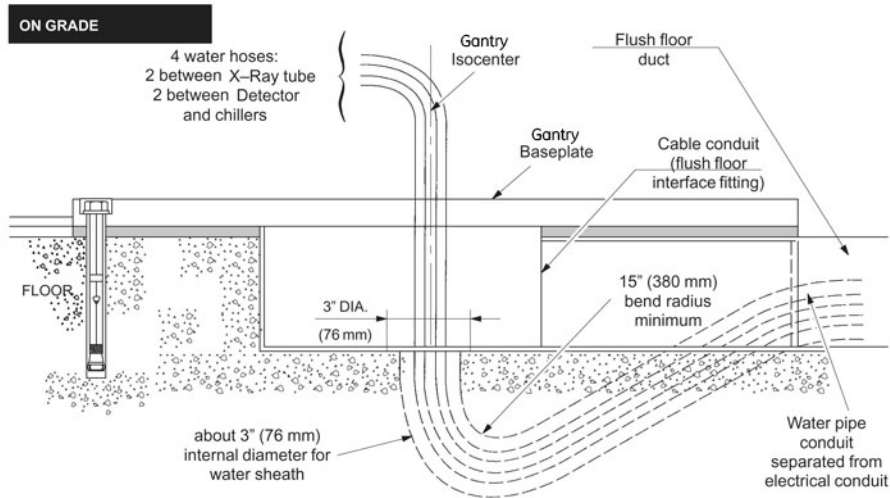

**Note:** Flush floor interface fitting is part of GEMS installation kit 2286398 and is installed by Customer or customer's Contractor.

Figure 81 Cable Curvature with "Above Grade" anchor kits

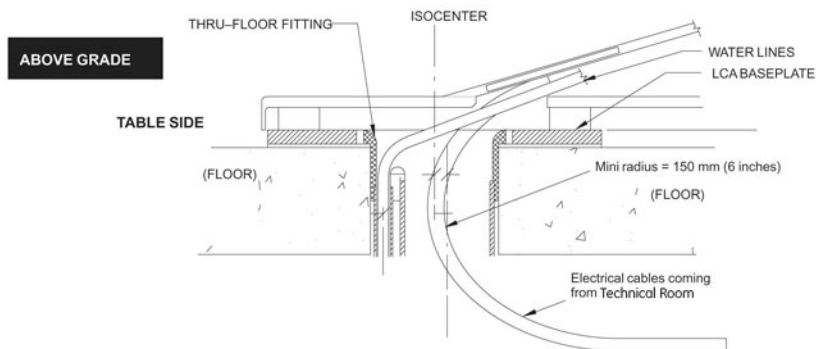

**Note:** In case of thru-floor cabling, if the electrical cables are coming from the head side, they will need to have a minimum curvature with a minimum radius of 150 mm (6"). In any other cases (i.e. flush floor) no such curvature is allowed.

Figure 82 Cable Curvature with "On Grade" anchor kits

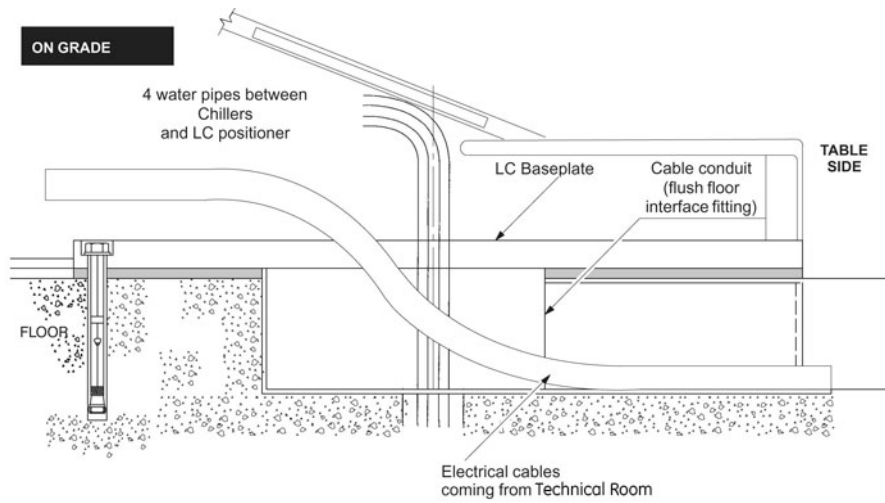

**NOTE**

In case of on grade cabling, because of the minimum curvature constraint of 150 mm (6"), the cable will have to come from the side between the Gantry and the Patient Table.

## 2.3.3 Mounting Requirements

### 2.3.3.1 Positioner and Table Floor Mounting

The distances between the Gantry and the Tables are critical for a proper clinical usage. For this reason, GEMS provides two floor mounting templates to ensure these components are properly placed in relation to one another.

Figure 83 Gantry Floor Mounting Methods (1/2)

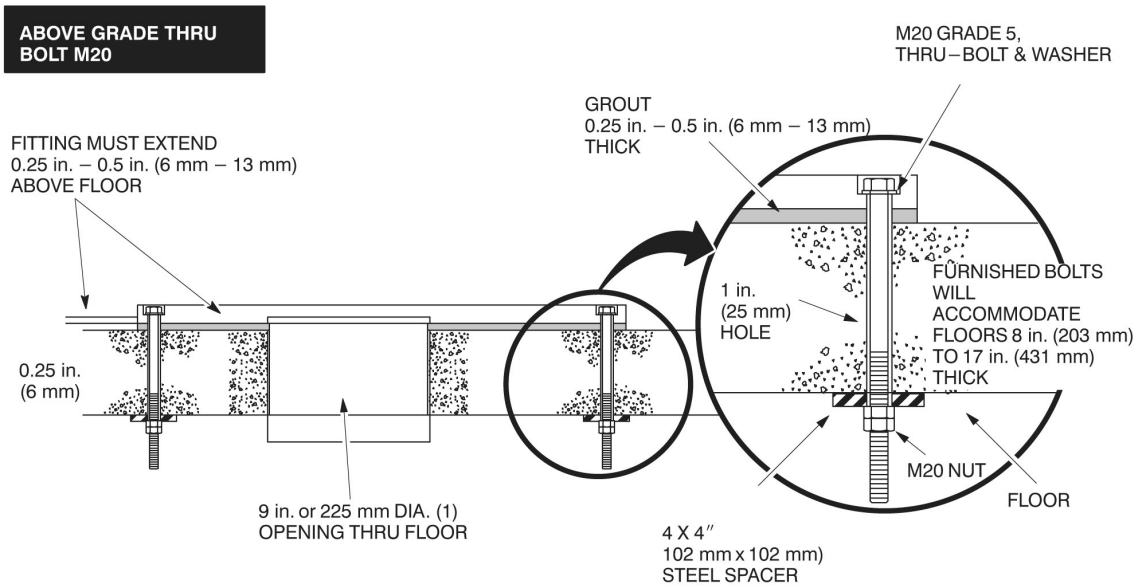

(1) The US or the METRIC standard for base plate inner

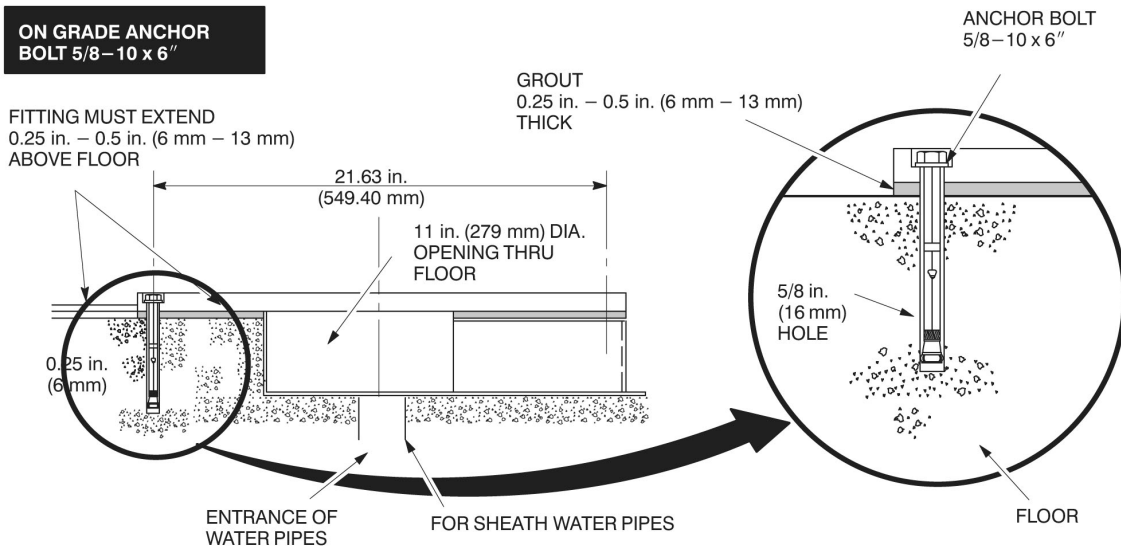

Figure 84 Gantry Floor Mounting Methods (2/2)

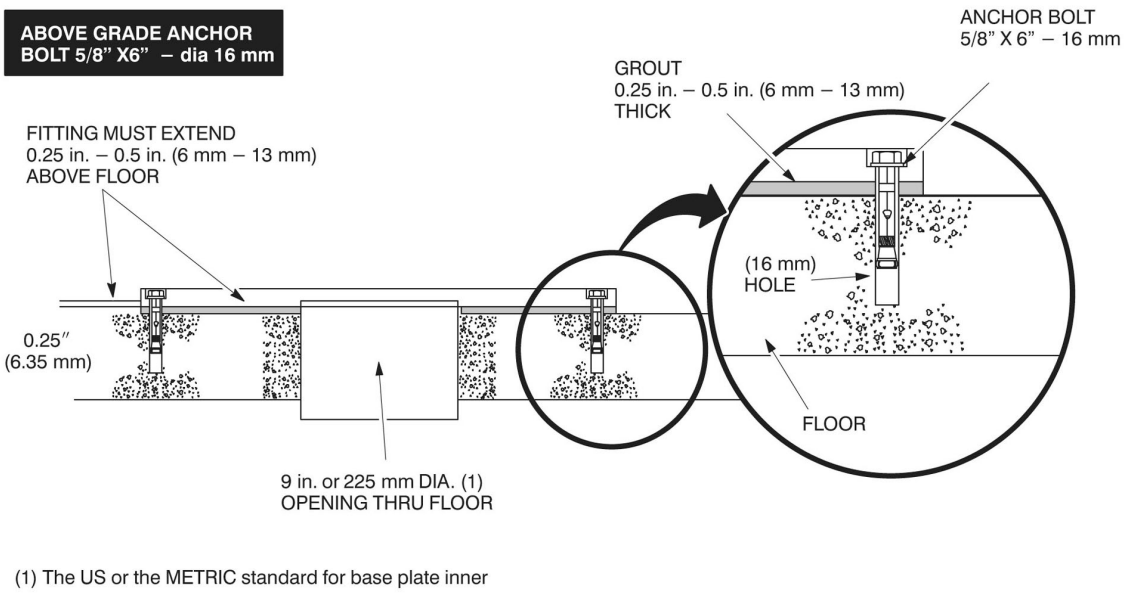
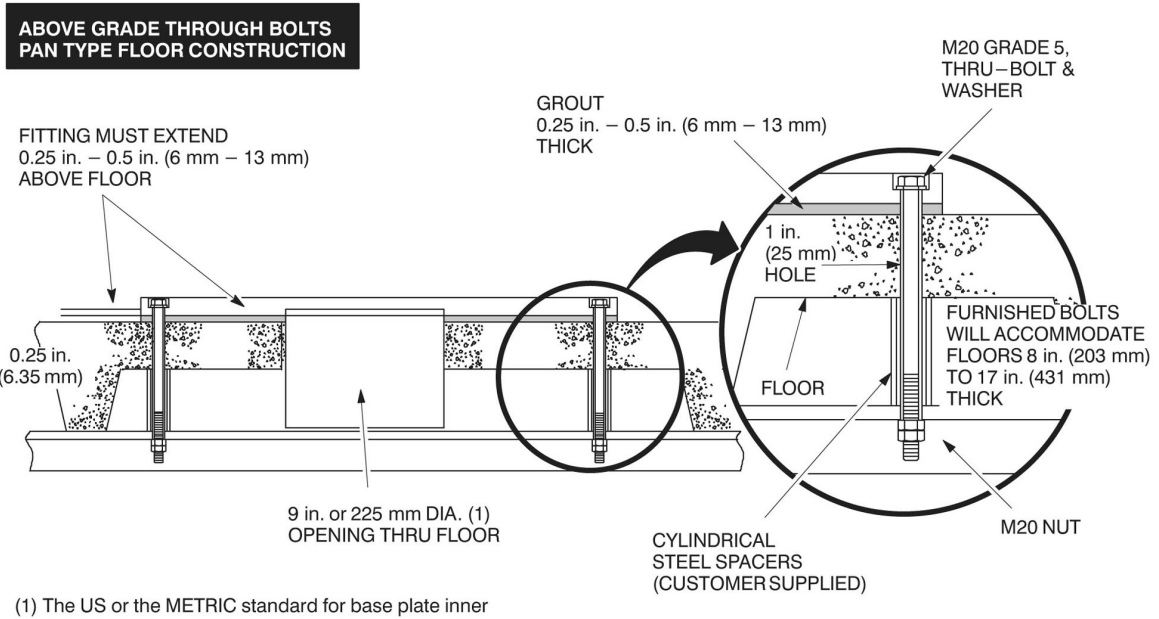

Figure 85 Inner Base Plate (Water Electric Separator) for Above Grade Floor Anchor Kit

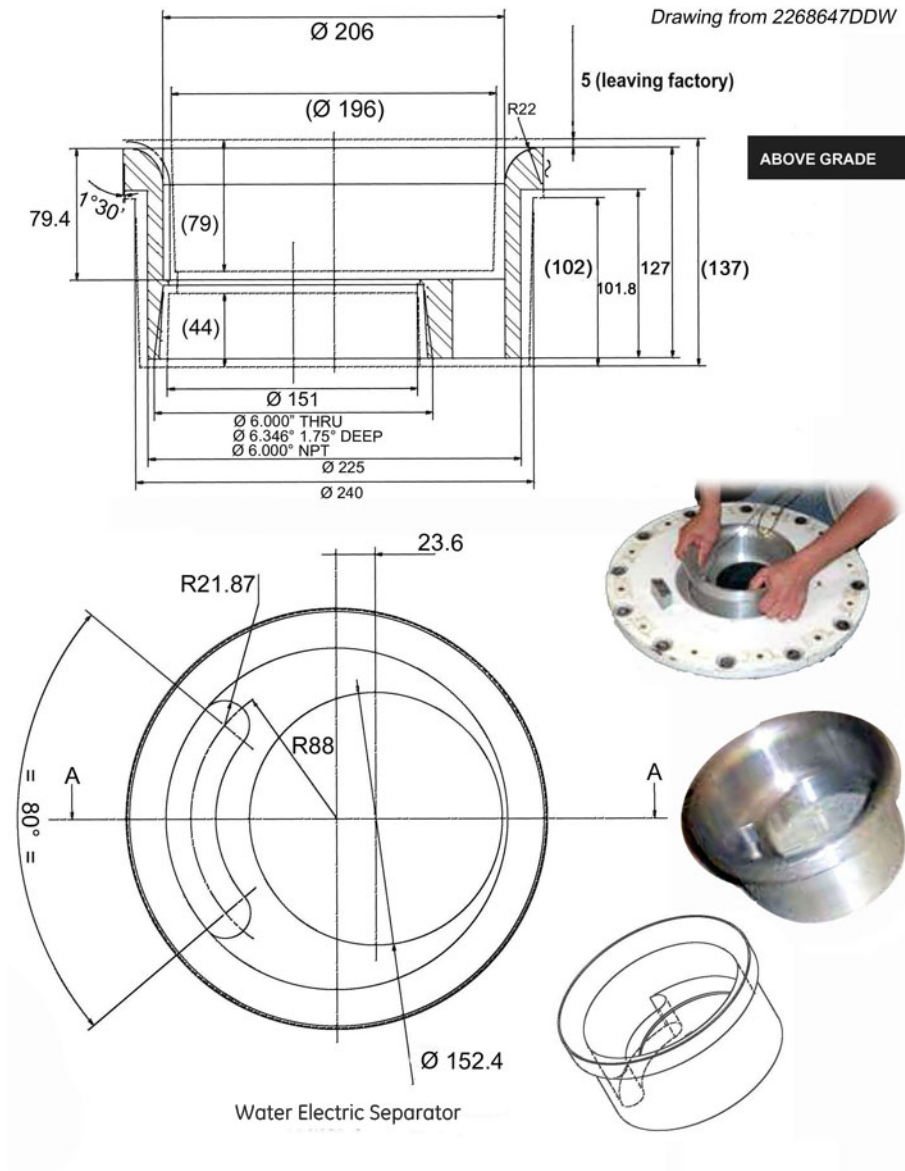
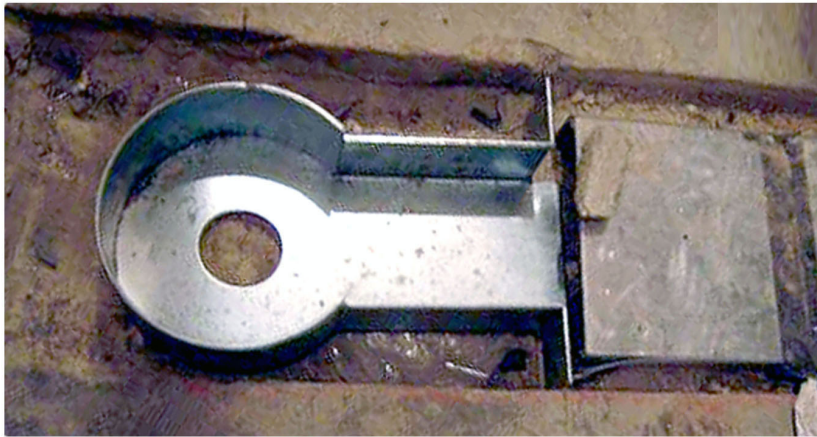
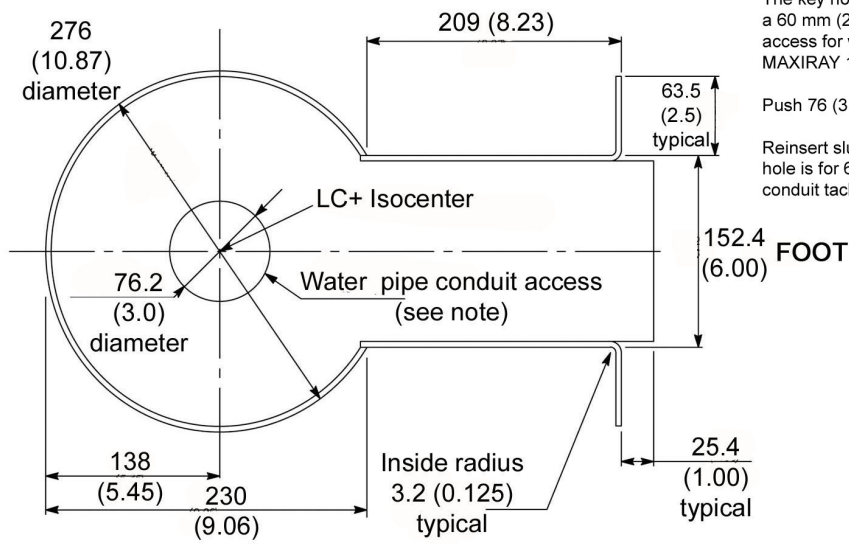

Figure 86 Cable Conduit For On-Grade Floor Anchor Kit



Dimensions in mm (inches)

**ON GRADE**



The key hole has been redesigned to permit a 60 mm (2.5 in.) water conduit to separate access for waterpipes used with a MAXIRAY 150.

Push 76 (3.0) hole in center.

Reinsert slug and tack well in one spot hole is for 63.5 (2.5) internal diameter conduit tack well from bottom if possible.

**FRONT VIEW**

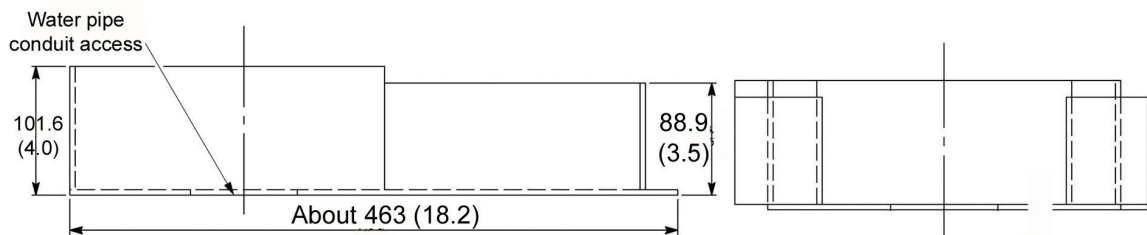

**SIDE VIEW**

Steel plate (0.12 in) OR 3mm Thickness

FINISH: F50FX2A.1

**FRONT VIEW (FOOT END)**

Figure 87 Fixing Bolt Overview

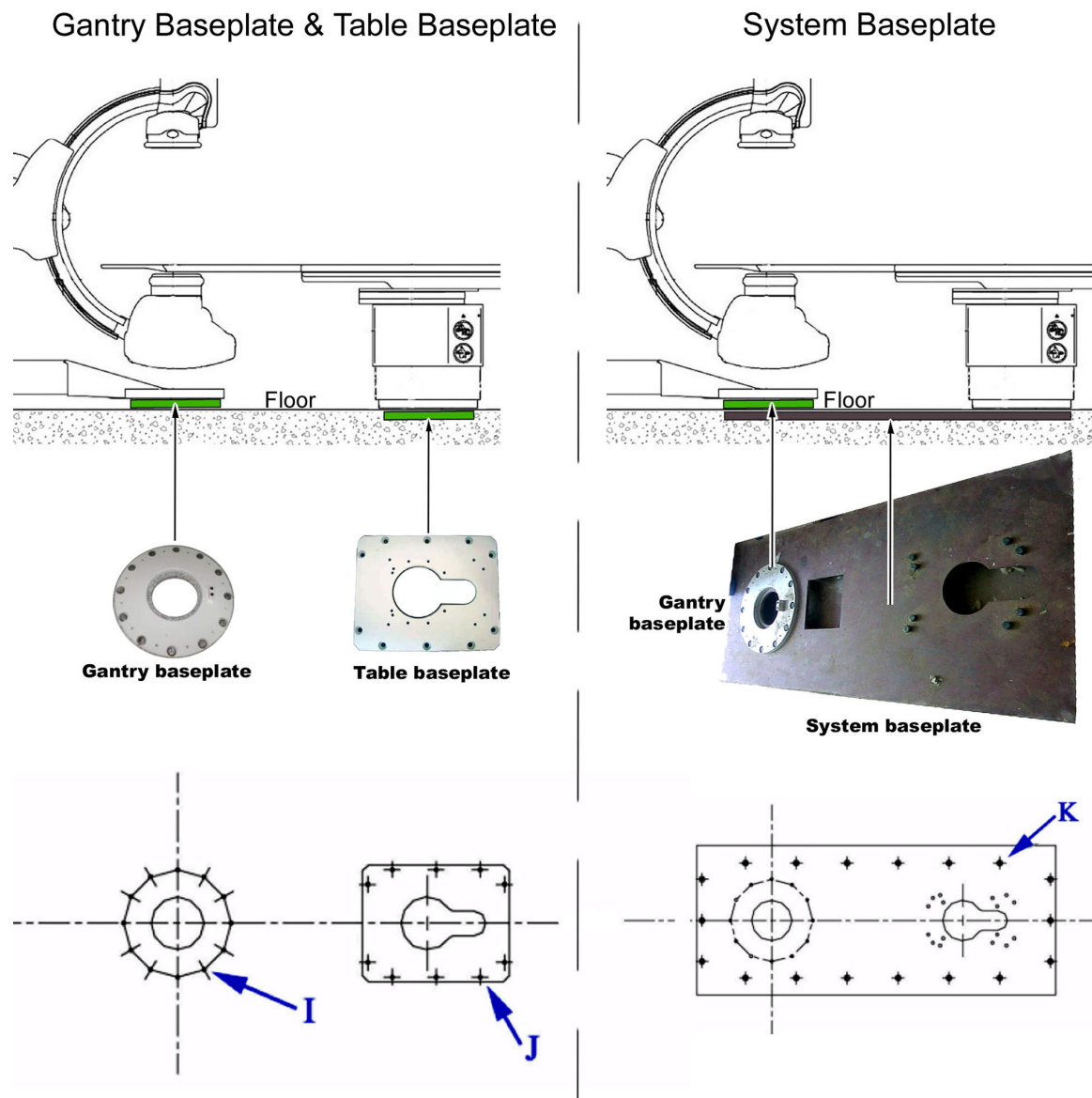

**NOTE**

For more details on Floor plate or Base plates, refer to Figure 88 on page 102 and illustration *Hole location in concrete floor* in 2.3.2 Floor Requirements on page 88.

**NOTE**

With any kind of fixation methods (Bolts M20, Mechanical anchors or Chemical anchors), the mandatory number of holes used is:

- Gantry base plate : 12 max and 8 min holes used are acceptable
- Table base plate : 10 max and 8 min holes used are acceptable
- Floor base plate : 24 max and 12 min holes used are acceptable.

We can have only 2 consecutive holes omitted.

**NOTE**

In case of floor plate configuration, the gantry base plate shall be mounted onto the floor plate, but the table base plate shall not be mounted on the floor plate.

**Pull out efforts and recommendations about chemical anchors not provided by GE.**

The following table provides the recommended chemical anchors for Table/Gantry base plates and for the floor plate ordered locally that they could be used instead of bolts provided by GE.

**Table 17 Chemical anchors Pull out efforts and recommendations**

	Gantry Base Plate	Table Base Plate	Floor Plate (to be ordered locally)	Table Omega
Mark	I on Figure 87 on page 99	J on Figure 87 on page 99	K on Figure 87 on page 99	A on Figure 88 on page 102
Pull out effort	736 daN per bolt if 12 used and 1992 daN per bolt if 8 used	1120 daN per bolt if 10 used and 2000 daN per bolt if 8 used	272 daN per bolt if 24 used and 2008 daN per bolt if 12 used	4432 daN per bolt with 4 bolts
Number of holes in the plate	12 max (8 min mandatory)	10 max (8 min mandatory)	24 max (12 min mandatory)	4 mandatory
Recommended chemical anchors example 1	Supplier HILTIHVU adhesive capsule + HAS Anchor rod	Supplier HILTIHVU adhesive capsule + HAS Anchor rod	Supplier HILTIHVU adhesive capsule + HAS Anchor rod	Supplier HILTIHVU adhesive capsule + HAS Anchor rod
Threaded rod	M16 A4-70 / 333 131 5/8	M20 A4-70 / 333 135 3/4	M16 A4-70 / 333 131 5/8	M20 A4-70 / 333 135 3/4
Hole diameter in the floor	18 mm (11/16 in)	24 mm (7/8 in)	18 mm (11/16) in	24 mm (7/8 in)
Hole depth in the floor	125 mm (5 in)	170 mm (6-5/8 in)	125 mm (5 in)	170 mm (6-5/8 in)
Minimum floor thickness	180 mm (7 in)	220 mm (8-1/2 in)	180 mm (7 in)	220 mm (8-1/2 in)
Max Tightening Torque	80 N.m (59 ft-lb)	150 N.m (110 ft-lb)	80 N.m (59 ft-lb)	150 N.m (110 ft-lb)

**NOTE**

The floor plate ordered locally needs to be in steel.

Refer to supplier technical documents for all specification and installation data about chemical anchors.

Figure 88 Gantry and table mounting holes

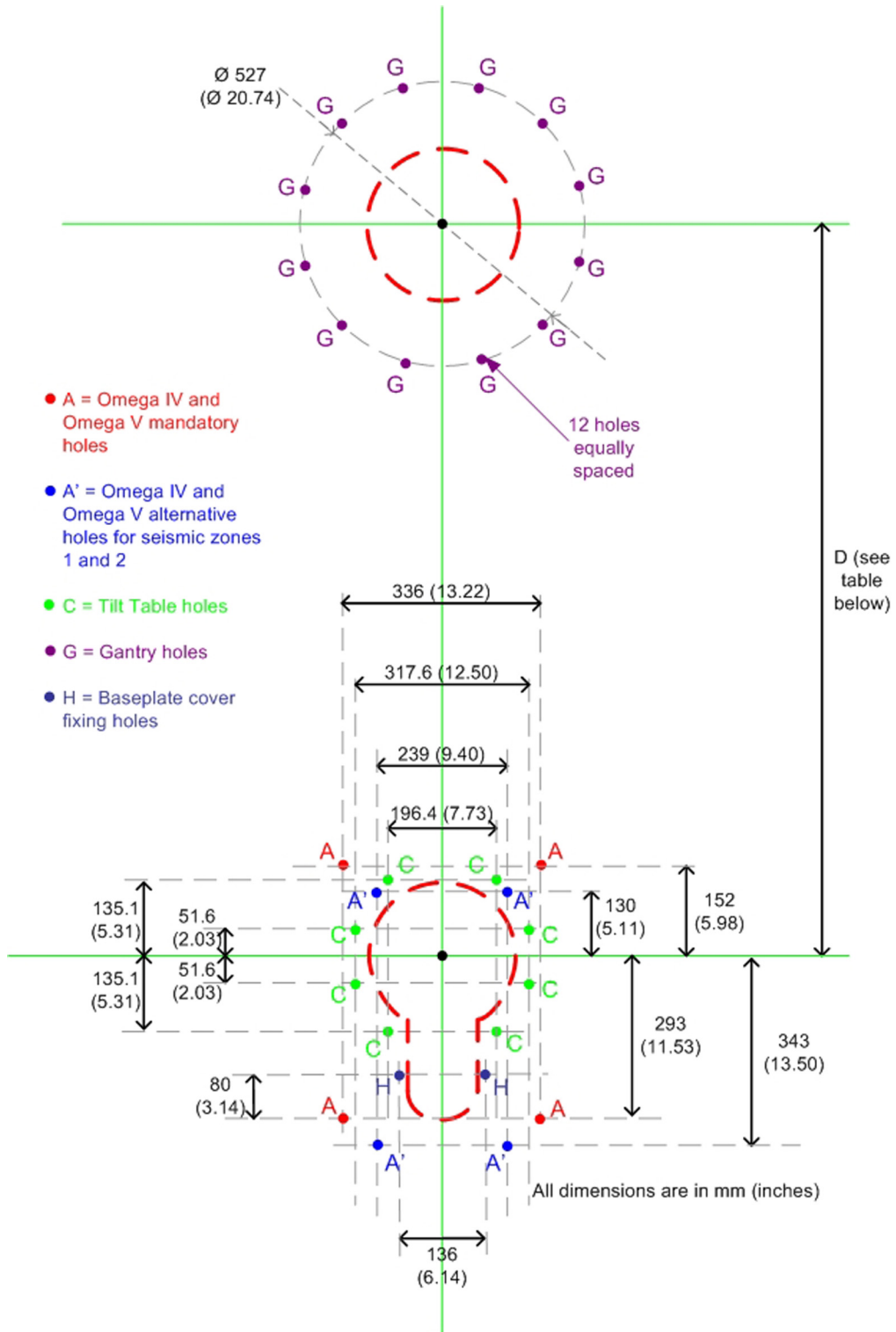

Table 18 D distance

	ANGIO mm (in)	CARDIO mm (in)	NEURO mm (in)
Omega IV Compact Table	Not applicable	1395 (54.9)	Not applicable
Omega V Long Table	1278 (50.3)	1395 (54.9)	1395 (54,9)
Innova <sup>IQ</sup> and Innova <sup>IQ</sup> OR Table	1278 (50.3)	1395 (54.9)	Not applicable

### 2.3.3.2 Gantry Table Floor Preparation Kits (GE supplied)

Refer to *.Single Plane and Biplane Innova Systems - Pre-Installation Kit Installation Procedures.*

## 2.3.4 Ceiling Requirements

### 2.3.4.1 Third Party Monitor suspension (option)

Attention must be paid to the height of suspended elements of the third party monitor suspension, collision must be avoided with the gantry.

Figure 89 Gantry and Third Party Monitor Suspension

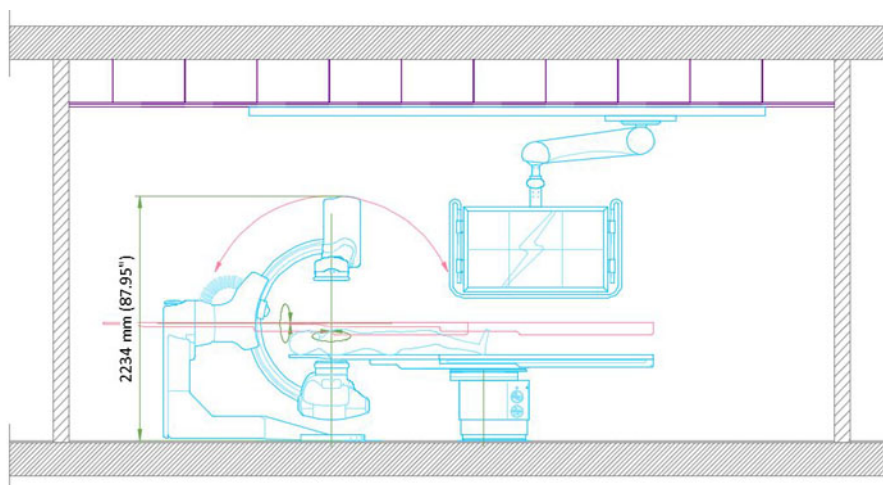

### 2.3.4.2 Mavig suspension with rails

Aluminum rails support the In-Room Monitor bridge used in Innova system X-Ray rooms.

**Reference:**

For additional details on ceiling requirements for stationary rails, refer to: - Direction 46-019639, *Advantx (VHLA) XT Stationary Rails Installation and Adjustment.*

When evaluating ceiling you must take into account the mounting information below.

### 2.3.4.1 Rail Mounting

Attach stationary rails to structural steel with through-bolts in concrete ceilings. Do not use screw anchors in direct tension.

Mount stationary rails directly to the ceiling slab or to flush-mounted unistrut or halfen structure. In higher rooms with false ceiling, mount stationary rails to rigid vertical members hung from ceiling slab.

Securing a supplementary channel to the bottom of the vertical members and mounting the stationary rails to this channel can greatly reduce the number of vertical members.

The stationary rail support structure must be leveled before installation can begin. Do not assume that any support structure is level within specified tolerances, particularly after removing suspensions from an existing room.

### 2.3.4.2 Bolt Specifications (Mavig suspensions)

- The maximum load per bolt will not exceed **1557 N**.
- Each bolt must not “pull out” or otherwise fail under a vertically downward *dead* load of **6227 N**.

### 2.3.4.3 Select Rails (Mavig suspensions)

All XT Stationary rails are with a select length process. Detail of available length is illustrated in [1.3.5 European Process Order Select on page 20](#).

**Figure 90 Specifications for a typical 17'-10" (5.44 m) inboard stationary rail mounting interface (both rails ceiling mounted), for Mavig suspension**

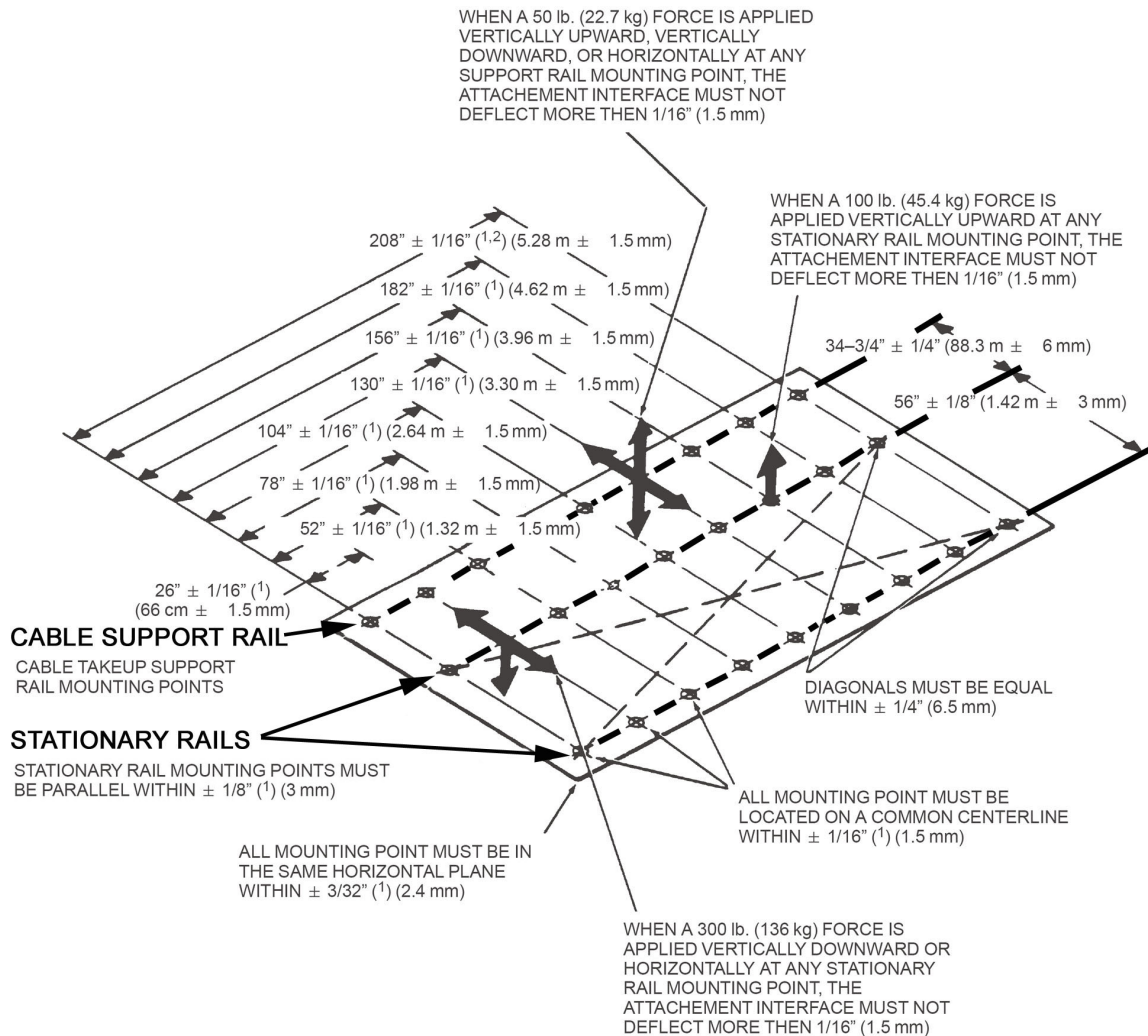

**Table 19 Stationary rail in different length**

Rail length cm (in)	A	C	D	INBOARD RAILS
472 (186")	7*660.4=4,623	-	51	B0186JA
579 (228")	8*660.4=5,283	406	51	B0228JA

**2.3.4.4 Cable Support for Monitor Cables**

The rails & cable drape are provided with the system, except for the USA, where the Cable Support Kit must be provided locally by the Customer (e.g. CPGE55 from Unistrut).

### 2.3.4.3 MAVIG suspension with fixed point dual arm for Large Display Monitor

The Substructure for Dual Arm suspension is used to attach the MAVIG suspension with fixed point dual arm to the solid ceiling. It is used as the bridging element between the solid ceiling and the false ceiling for the installation and the fixation of the suspension.

Also, it provides a hooking point required for the installation and the replacement of the Large Display Monitor.

The Substructure for Dual Arm suspension is mandatory to install the MAVIG suspension with fixed point dual arm for Non-seismic Zones. For Seismic Zone installations, refer to Structural Engineer for appropriate design of the structure for installing the MAVIG suspension system.

For standard site configurations, the distance between the ceiling and the lower edge of the false ceiling should be in a range of minimum 175 mm and maximum 610 mm.

If the distance between the ceiling and the false ceiling is less than 175 mm, then the middle plate is not installed. Refer to [Table 20 on page 106](#)

The Substructure for Dual Arm suspension is delivered with each system. In the GEHC system catalogue (Pre-Installation item), its purchase number is S18391MX (MAVIG Purchase number GD60D022).



**NOTICE**

If the distance between the ceiling and the lower edge of the false ceiling is more than 610 mm, Long variation of the Substructure for Dual Arm suspension solution could be proposed by MAVIG.

**Table 20**

Distance between ceiling and false ceiling	Configuration of the Substructure for Dual Arm suspension	Item and Description
Minimum is 175 mm and maximum is 610 mm		<ul style="list-style-type: none"> <li><b>1</b>: Weight in kg</li> <li><b>2</b>: Ceiling Plate</li> <li><b>3</b>: Middle Plate</li> <li><b>4</b>: Maximum is 155 mm</li> <li><b>5</b>: Maximum is 175 mm</li> </ul>
Less than 175 mm		

### 2.3.4.1 Substructure for Dual Arm suspension mounting

The length of the Substructure for Dual Arm suspension S18391MX can be adapted to any individual situation (distance between solid ceiling and the lower edge of the false ceiling).

Length calculation and adaptation instruction are provided in the MAVIG substructure assembly instructions DBF0100X (where X may be 1 or higher).

The Substructure for Dual Arm suspension must be fastened to the ceiling using six suitable screws.

These screws must be dimensioned according to the conditions of the ceiling and provided by the customer and must be checked by the structural engineer.

The ceiling plate (Figure 57 on page 69) must be seated flush to the ceiling in order to ensure optimum load distribution.

The lower edge of the Substructure for Dual Arm suspension (Interface plate **1**) should be the same as the height as the lower edge of the false ceiling **2**

**Figure 91 False ceiling alignment versus interface plate**

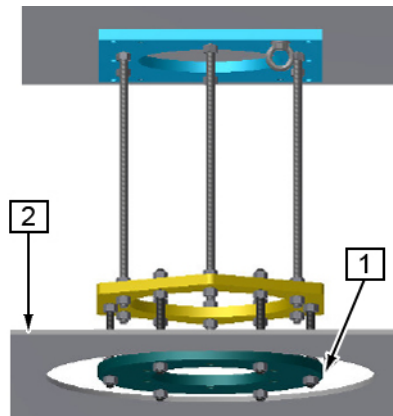

### 2.3.4.2 Bolt Specifications

The Substructure shall be fastened to the ceiling with following specifications:

- The maximum axial load per bolt will not exceed 7210 N.
- The maximum Shear load per bolt will not exceed 957 N.
- The maximum pullout force shall be calculated in accordance with local building codes and it is part of structural analysis done by customer.

### 2.3.4.3 False ceiling specifications

The false ceiling should include an opening around the interface plate to allow service engineers to install and replace the suspension and the Large Display Monitor.

The diameter of the opening should be in the range of 489-620 mm ([#concept\\_rbj\\_2hn\\_mz/fig\\_m2w\\_vpn\\_mz](#)).

A trapdoor in the false ceiling should be provided to allow service access for cables management after mechanical installation of the suspension.

The distance between the substructure and the trapdoor should be less than 50 cm.

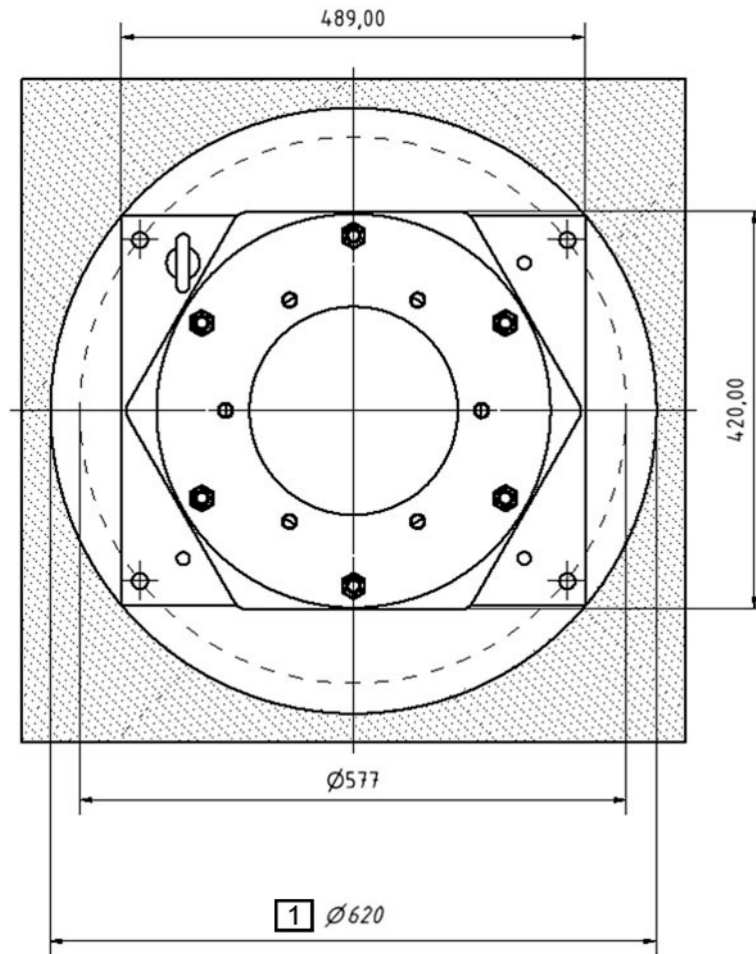

Item	Description
1	Port diameter of the false ceiling: maximum is 620 mm.

### 2.3.5 Wall Requirements

It is possible to install the second LDM on an optional swingout arm. It shall be mounted per the manufacturer's instruction provided in the OEM manuals list.

A hooking point shall be provided to allow the lifting on the LDM on the swingout arm or on a third-party suspension.

- Hooking point characteristic: It must withstand up to 440 lbs (200 kg).
- Recommended hooking point dimensions:

Figure 92 Hooking point dimensions

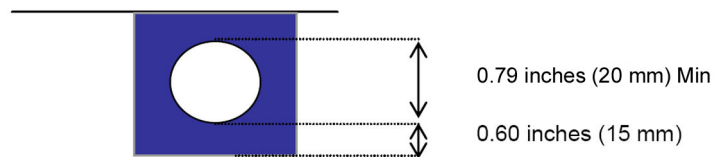

- Hooking point position:

Figure 93 Hooking point position for the swingout arm

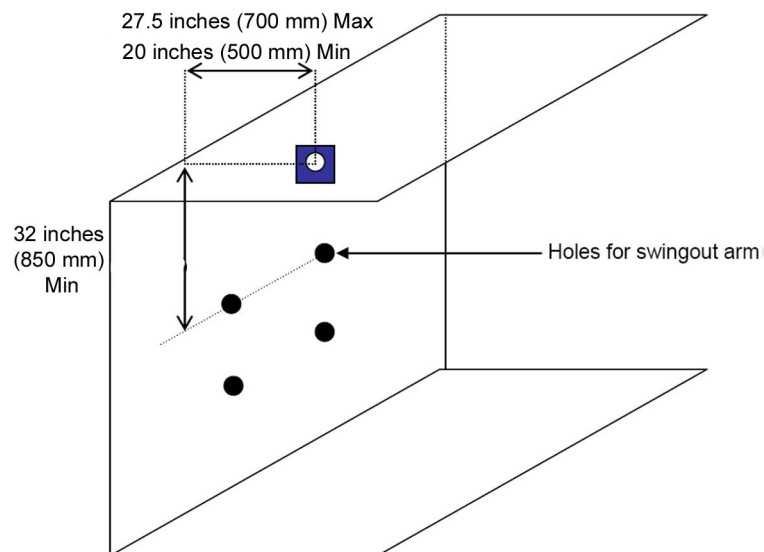

## 2.4 Mounting Data, Including Seismic

### 2.4.1 Seismic areas

Consider local seismic requirements when planning cabinet mounting.

Consult seismic expert to determine which mounting method is appropriate for the seismic region. Seismic requirements are determined and specified by the hospital/ Design Professional of record and may require approval by the specific state or country agency. Additional reinforcement in the walls may be required by specific seismic areas.

Contact your local GE Installation Program Manager to obtain the latest seismic calculations per the California Building Code (CBC) and the International Building Code (IBC).

The C-FRT Cabinet and the NPA PDU must be securely fastened to the wall and with their seismic kit to prevent them from tipping.

The C-FRT Cabinet, the NPA PDU, the Detector, the Tube Chillers and the Fluoro UPS are each provided with their own seismic kits, excluding the bolts, that shall be provided locally by the customer.

The following seismic kits can be ordered separately:

- Monitor Flat Panel Seismic Kit: 2353317
- VICIM seismic kit: 2365510
- 1 or 8 kVA UPS seismic kit: E4502YB.

**(For LDM Suspension with fixed point Dual Arm):**



THE STANDARD SUBSTRUCTURE (MAVIG GD60D022) SHOULD NOT BE USED WITH SYSTEM IN SEISMIC ZONE.

Contact MAVIG or Local contractor to design and supply specific substructure including M12 threaded holes requirement (see below).

Four M12 threaded holes with hooking point are required for the installation of the dual arm suspension, the installation and replacement of the Large Display Monitor. The structural support plate (I) should include these 4 x M12 threaded holes.

For the threaded holes positioning on the structural support plate refer to [Figure 57 on page 69](#).

## 2.4.2 Center of Gravity

The following shows center-of-gravity information for system components:

- C-FRT Cabinet, [Figure 94 on page 111](#)
- PDU Cabinet, [Figure 95 on page 112](#)
- 1 kVA UPS, [Figure 96 on page 112](#)
- 8 kVA UPS,
  - Power Module [Figure 97 on page 113](#)
  - Battery Module [Figure 98 on page 113](#)
- Fluoro UPS CE, [Figure 99 on page 114](#)
- Fluoro UPS UL, [Figure 100 on page 114](#)
- Tube Chiller, [Figure 101 on page 115](#)
- Detector Conditioner, [Figure 102 on page 115](#)
- Gantry, [Figure 103 on page 116](#)
- Omega IV Table, [Figure 104 on page 117](#)
- Omega V Long Table, [Figure 105 on page 117](#)
- Innova<sup>IQ</sup> and Innova<sup>IQ</sup> OR Table, [Figure 106 on page 118](#)
- 19" Desk Mounted Monitor, [Figure 107 on page 118](#)
- Mavig Overhead Flat Panel Suspension, [Figure 108 on page 119](#)
- Large Display Monitor suspension with rails, [Figure 109 on page 120](#)

- Large Display secondary monitor Swing out arm, [Figure 110 on page 121](#)
- Large Display MAVIG suspension with fixed point dual arm, [Figure 111 on page 122](#)

**Figure 94 C-FRT Cabinet - Center of Gravity**

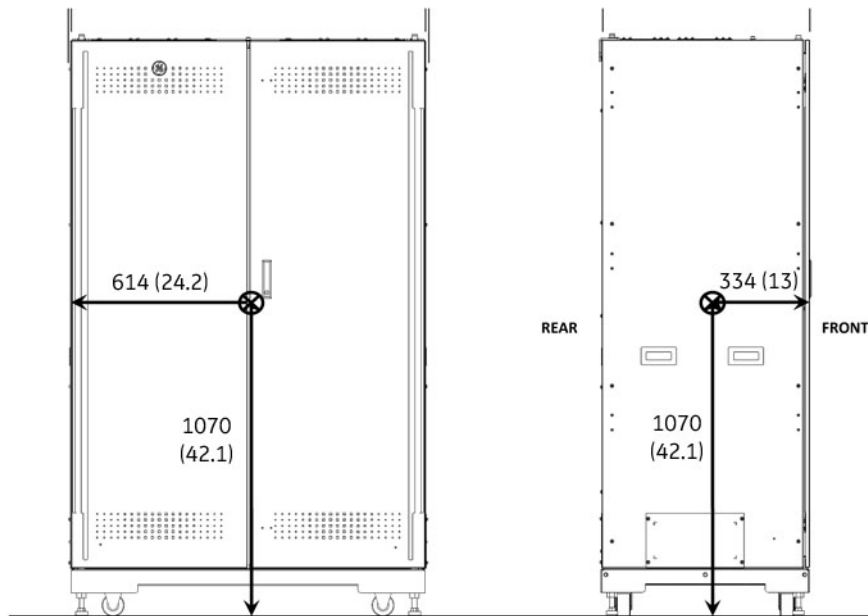

Dimensions in mm (in)

**Figure 95 NPA PDU Cabinet - Center of Gravity**

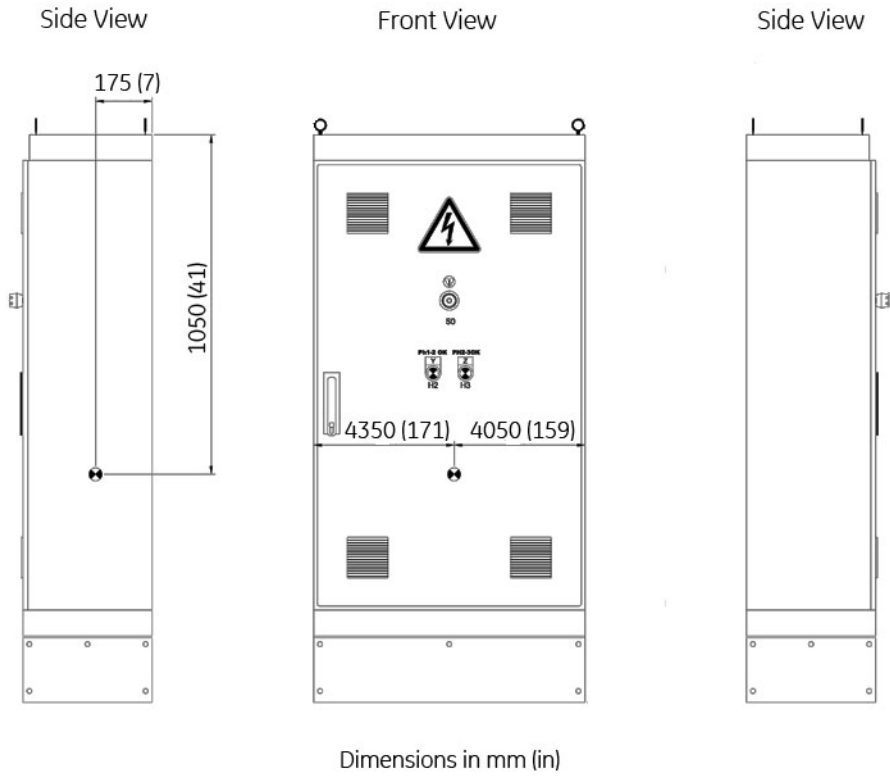

**Figure 96 1 kVA UPS - Center of Gravity**

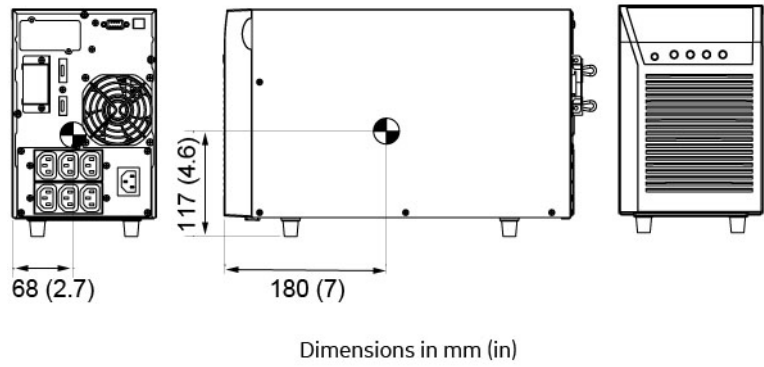

Figure 97 8 kVA UPS Power Module - Center of Gravity

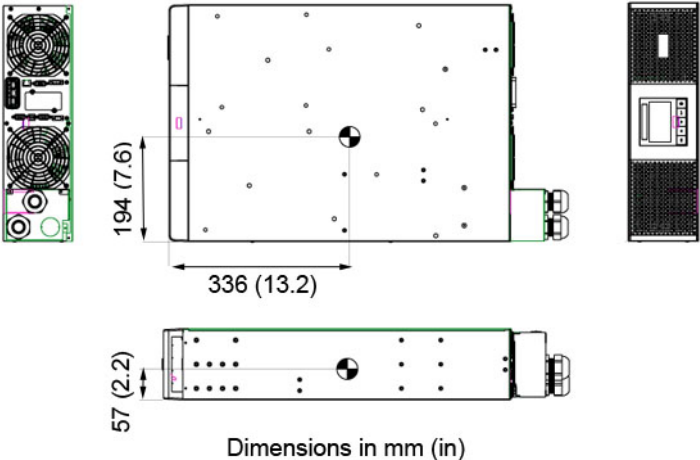

Figure 98 8 kVA UPS Battery Module - Center of Gravity

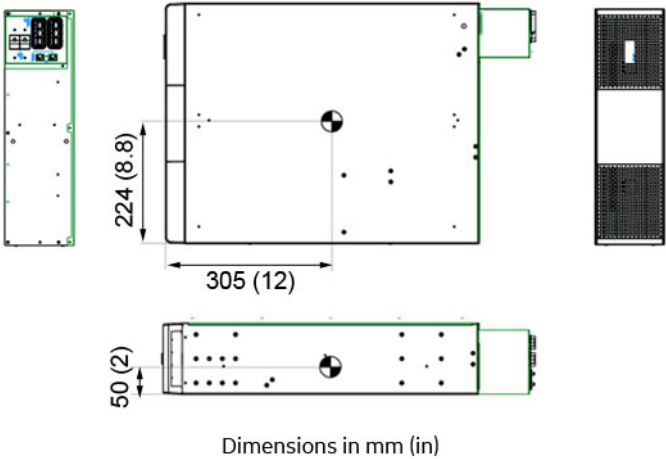

Figure 99 Fluoro UPS CE - Center of Gravity

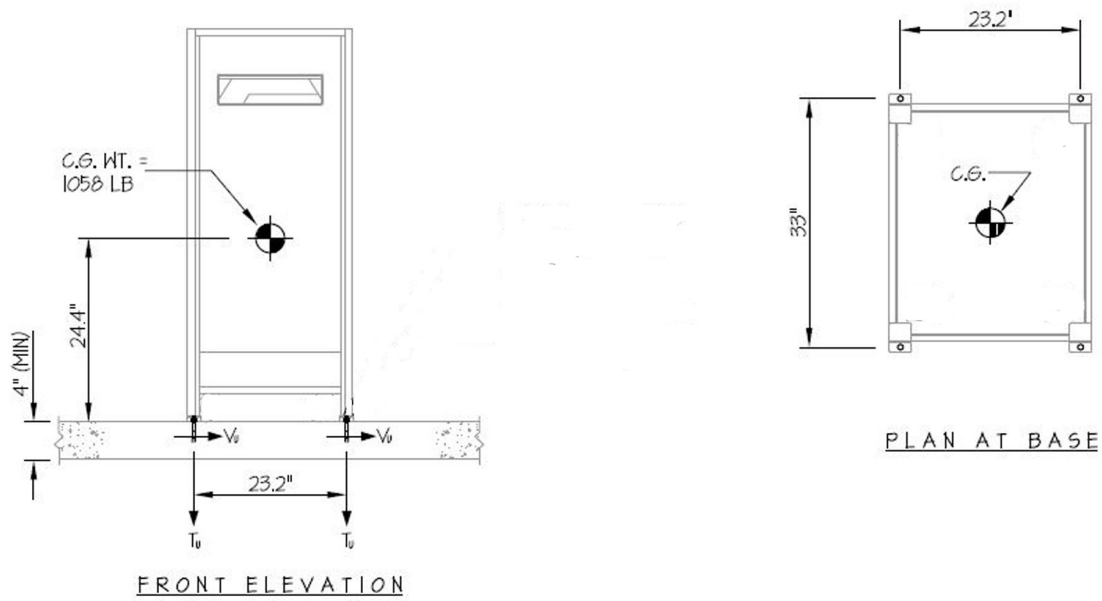

Figure 100 Fluoro UPS UL - Center of Gravity

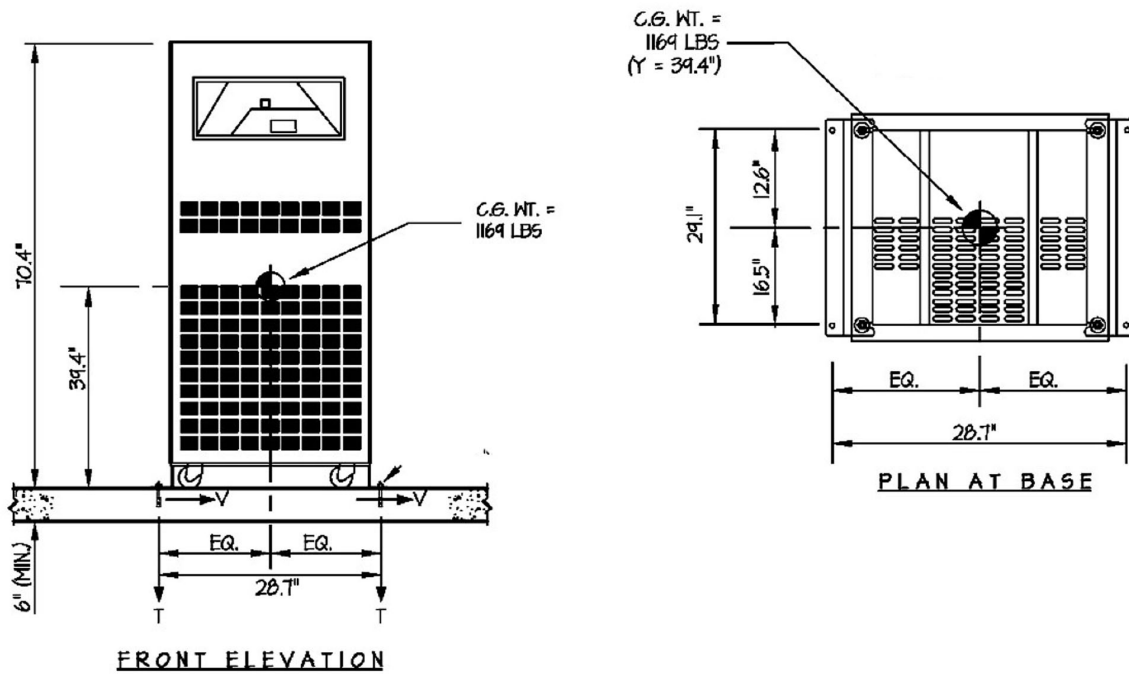

Figure 101 Tube Chiller - Center of Gravity

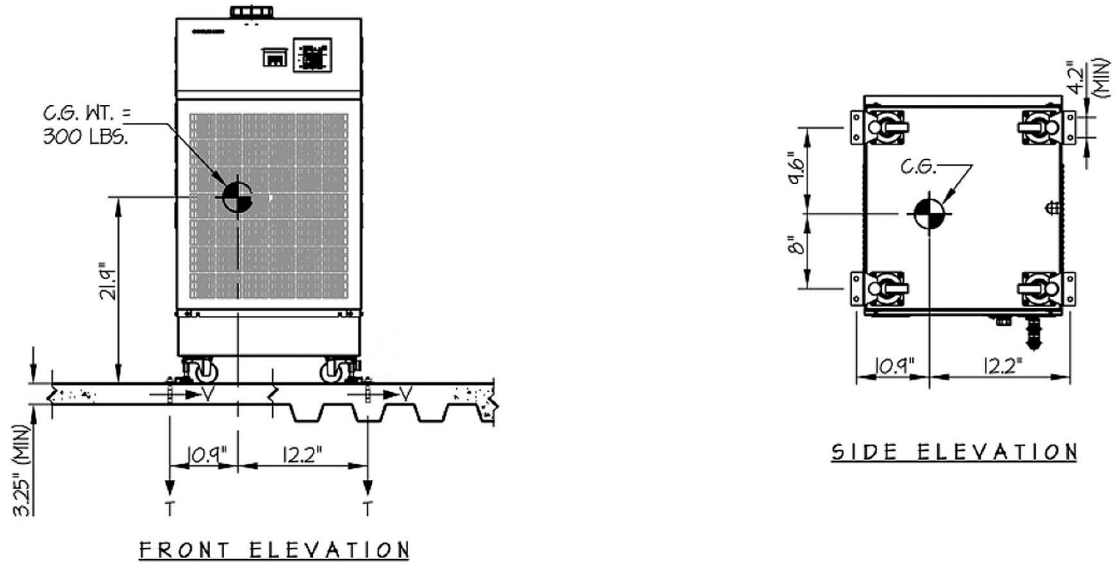

Figure 102 Detector Conditioner - Center of Gravity

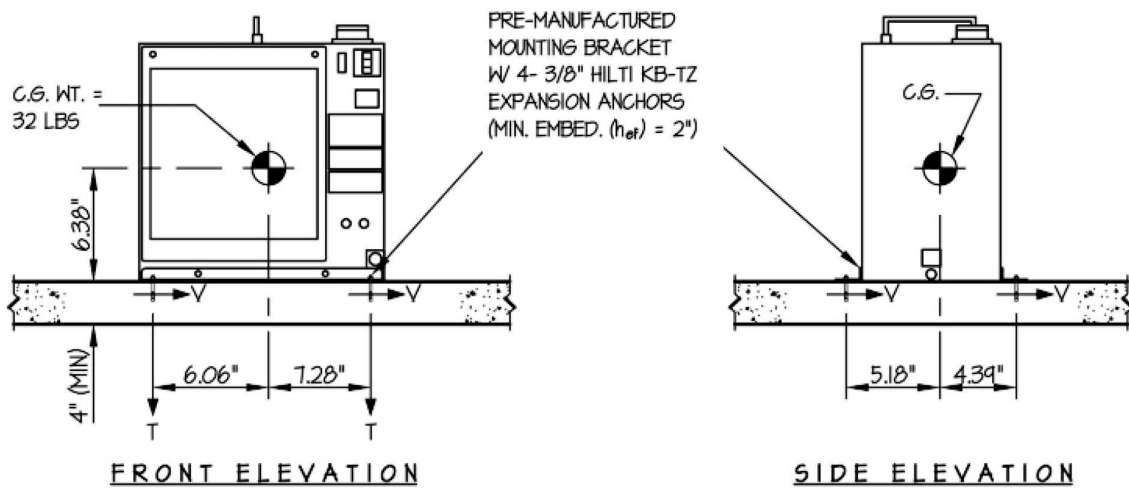

Figure 103 Gantry - Center of Gravity

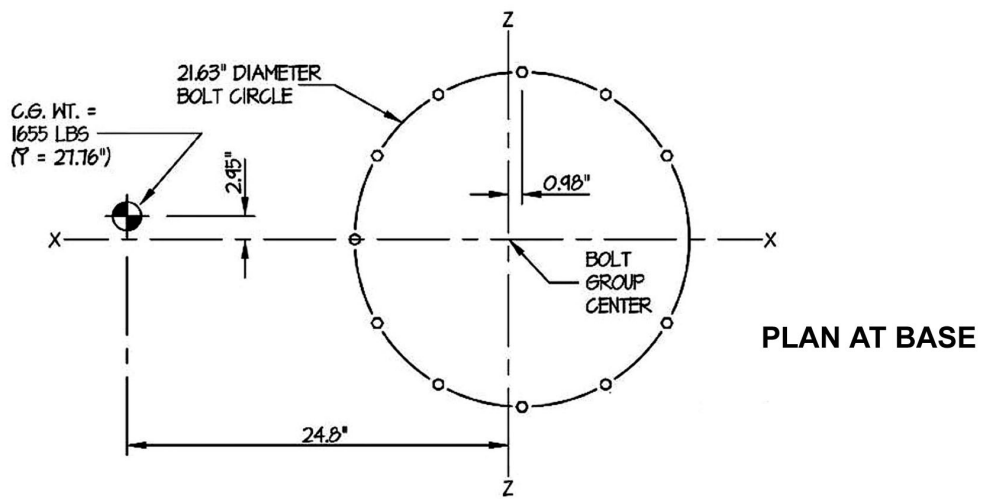
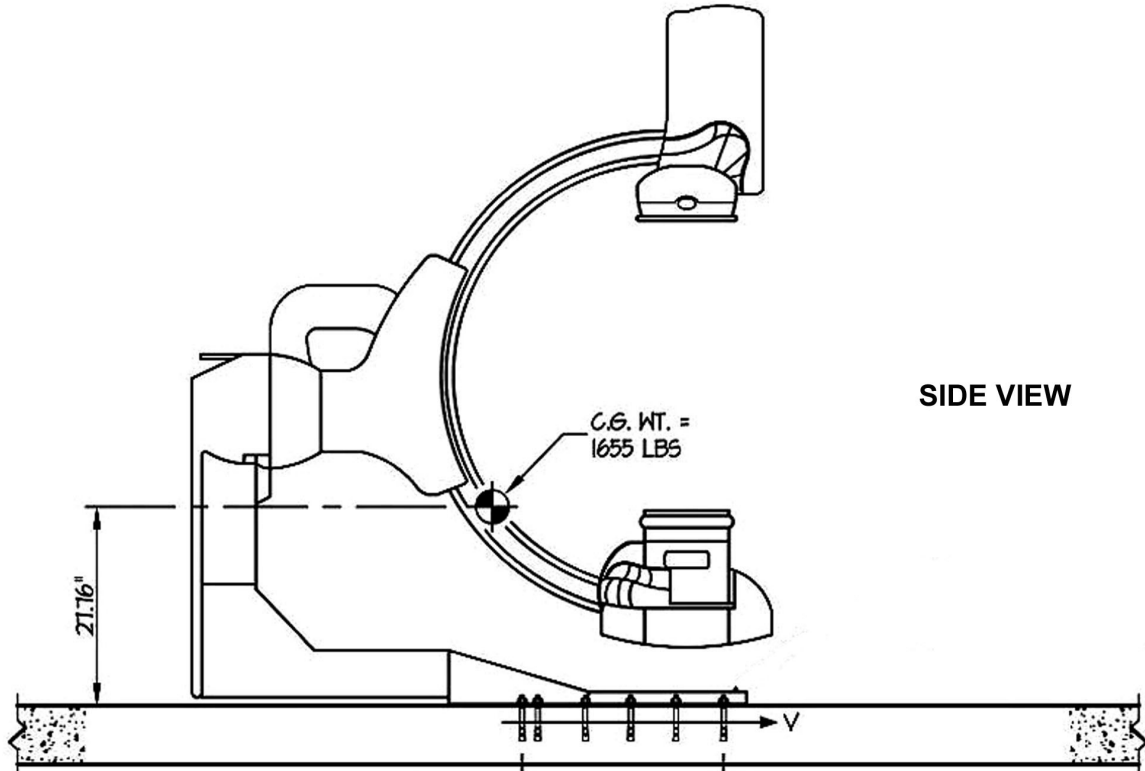

Figure 104 Omega IV Table - Center of Gravity

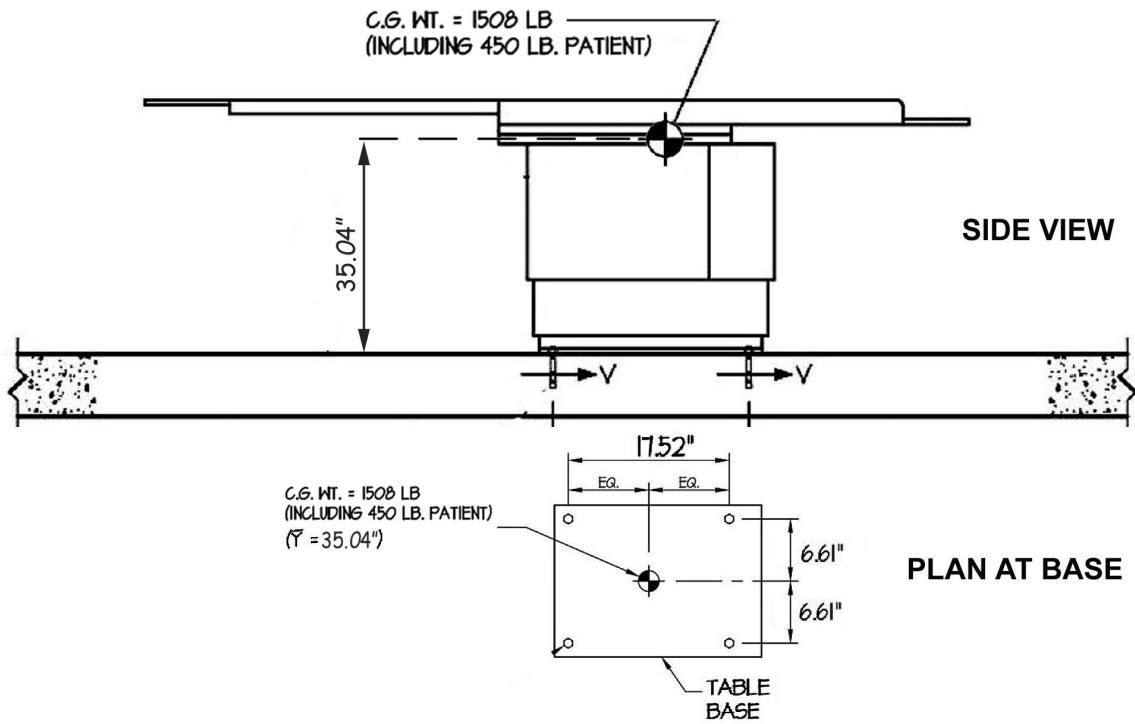

Figure 105 Omega V Long Table - Center of Gravity

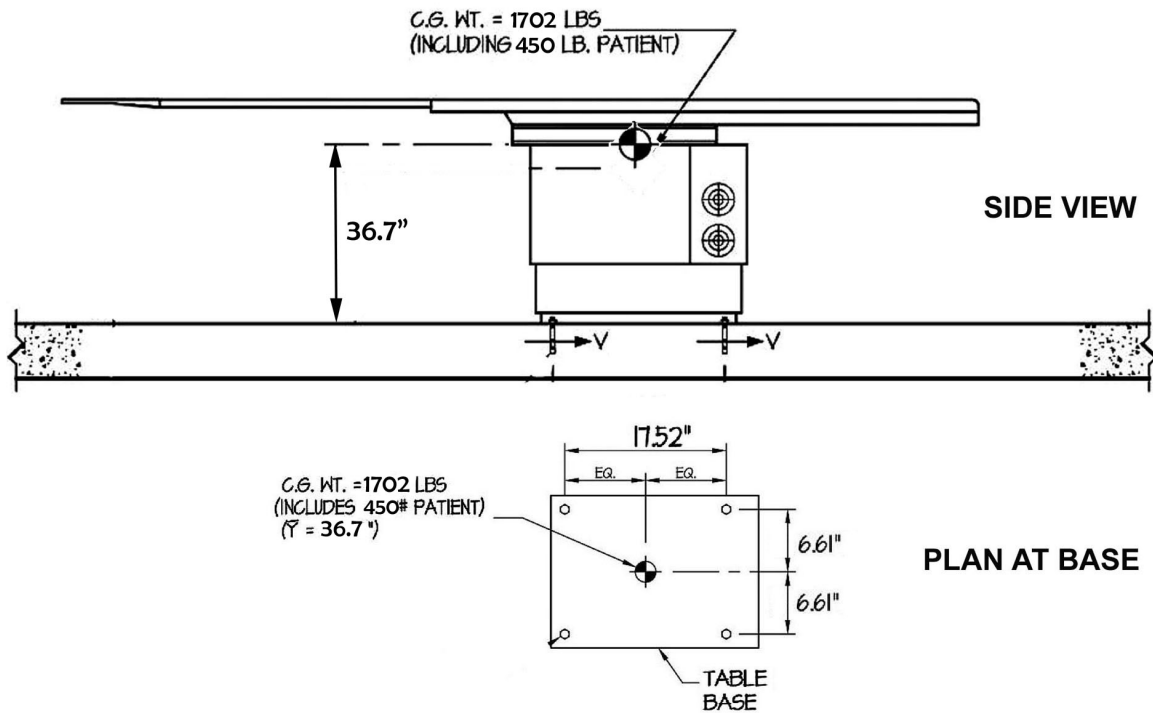

Figure 106 InnovalQ and InnovalQ OR Table - Center of Gravity

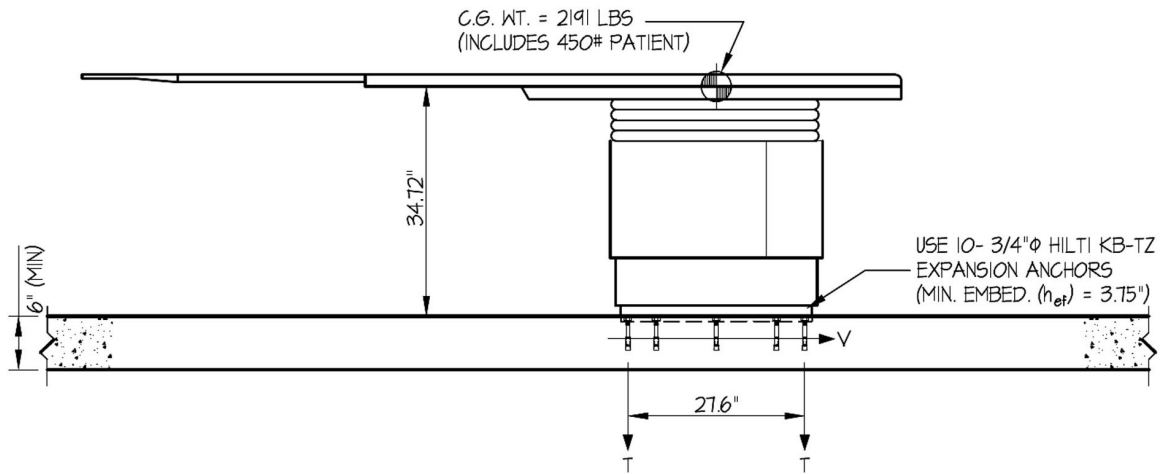
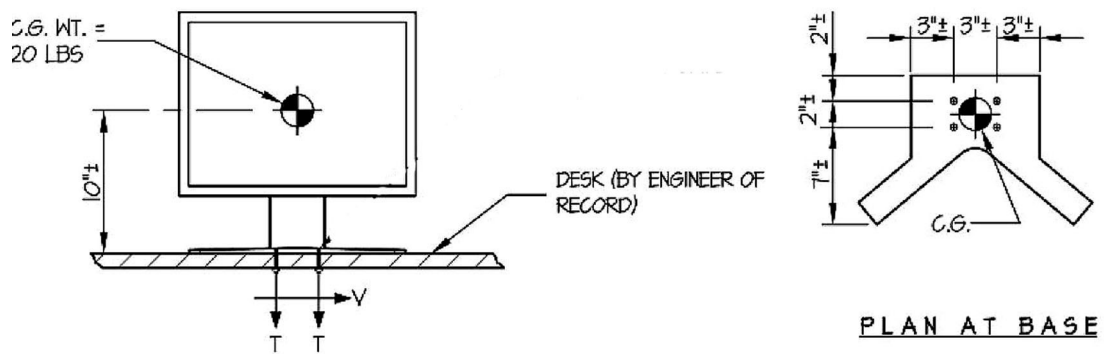

Figure 107 19" Desk Mounted Monitor - Center of Gravity



FRONT ELEVATION

Figure 108 Mavig Overhead Flat Panel Suspension - Center of Gravity

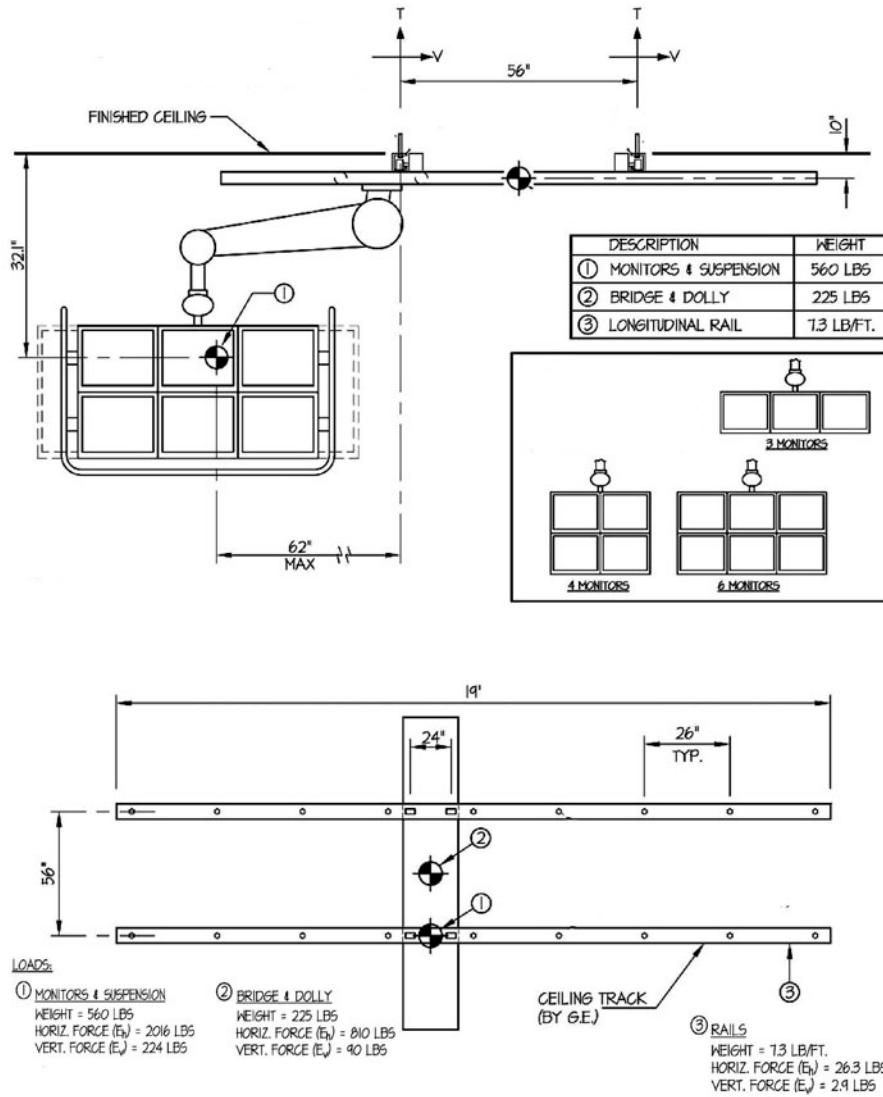

Figure 109 Large Display Monitor suspension with rails - Center of Gravity

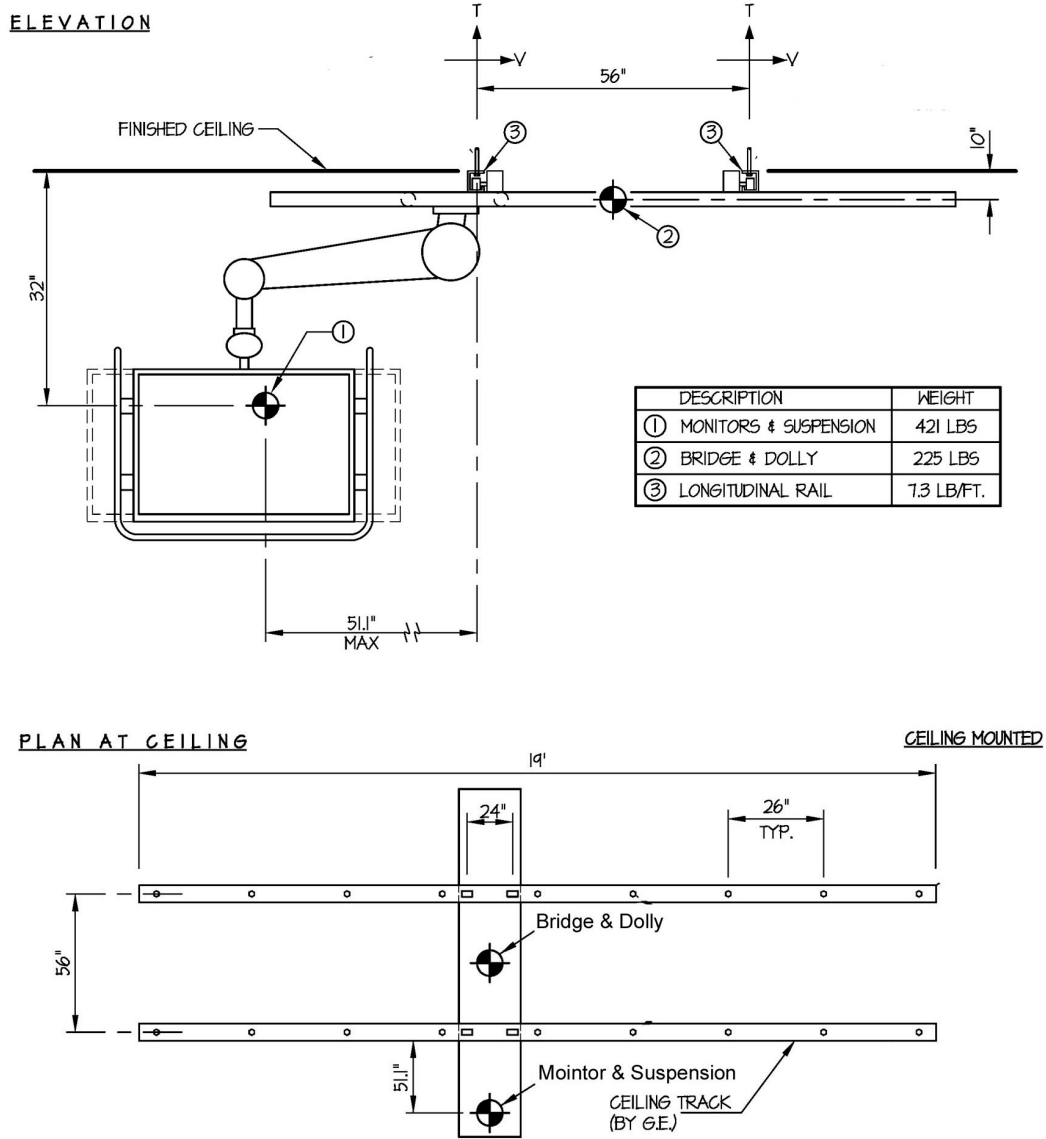

Figure 110 Large Display secondary monitor Swing out arm - Center of Gravity

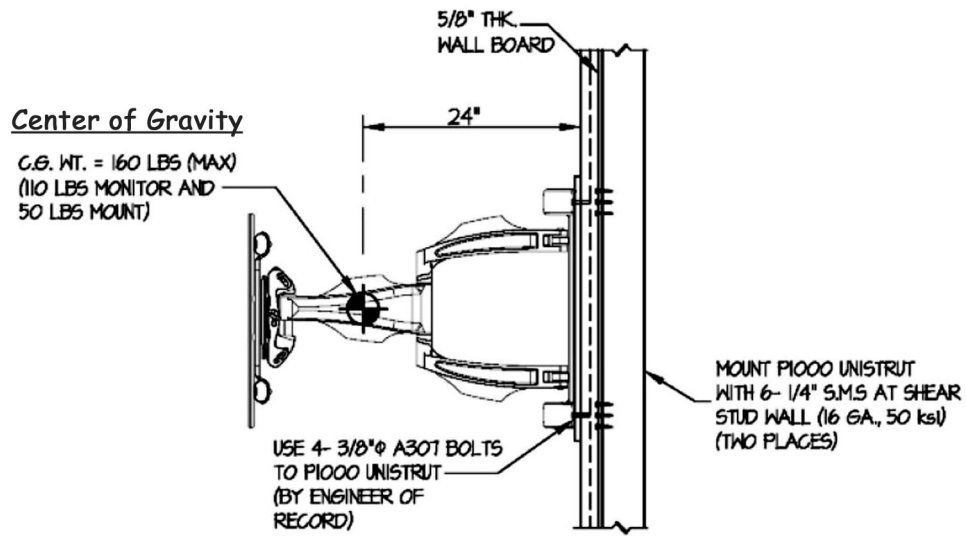
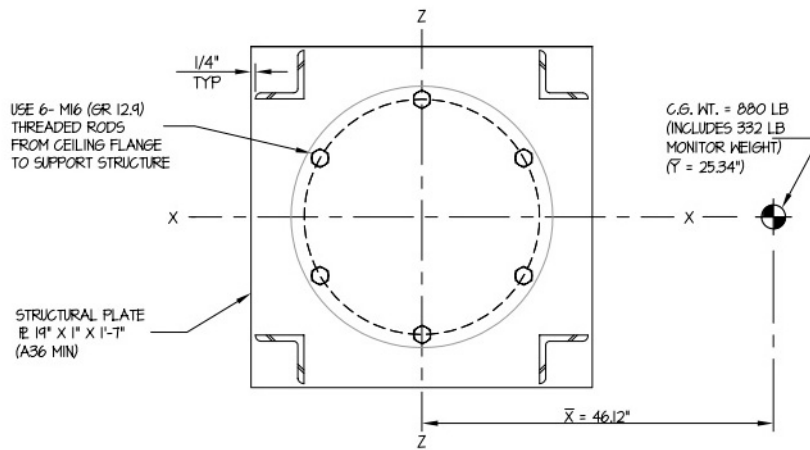
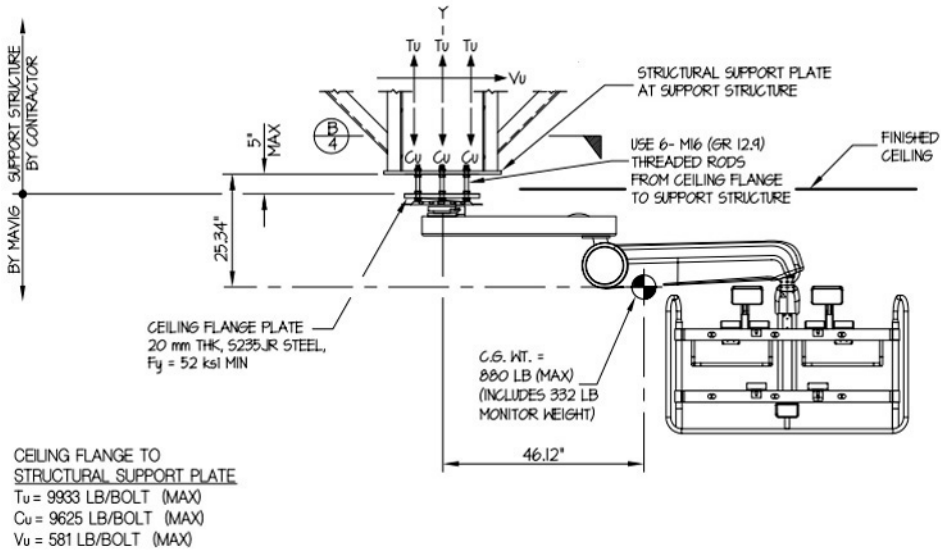

Figure 111 Large Display MAVIG suspension with fixed point dual arm - Center of Gravity



# Chapter 3 Special Construction Requirements

## 3.1 Radiation Protection

Because X-ray equipment produces radiation, special precautions may be needed or special site modifications may be required. GEHC does not make recommendations regarding radiation protection. It is the customer's responsibility to consult a radiation physicist for advise on radiation protection in x-ray rooms.

## 3.2 EMI Consideration

Information below on IEC60601-1-2 Electromagnetic Standard Compliance & Documentation can also be found in the IGS System Operator Manual.

### 3.2.1 General Scope

This equipment complies with IEC 60601-1-2: Edition 2.1, Edition 3 and Edition 4 EMC standard for medical devices.

The IGS System is intended to be used:

- in a PROFESSIONAL HEALTHCARE facility environment and,
- in a SPECIAL ENVIRONMENT for OR configuration System (vicinity of active HF SURGICAL EQUIPMENT – refer to Installations Requirements & Environment Control.

The System is suitable to be used in the electromagnetic environment, as per the limits & recommendations described in the tables here after:

- Emission Compliance level & limits ([Table 21 on page 124](#)).
- Immunity Compliance level & recommendations to maintain equipment clinical utility (see [Table 22 on page 125](#), [Table 23 on page 126](#) and [Table 26 on page 130](#)).

### 3.2.2 Electromagnetic Emission

The IGS System is intended for use in the electromagnetic environment specified below.

The Customer or the user of the System should assure that it is used in such an environment.

**Table 21**

Emissions	Test Compliance	Electromagnetic Environment
Radio-Frequency Emissions CISPR11	Group1 Class A limits (refer to Note)	<p>The IGS System uses Radio Frequency energy only for its internal function. Therefore, its Radio Frequency emissions are very low and are not likely to cause any interference in nearby electronic equipment.</p> <p>The IGS System is suitable for use in all establishments other than domestic and those directly connected to the public low-voltage power supply network that supplies buildings used for domestic purposes.</p>
Harmonic emissions IEC 61000-3-2	Not applicable	The IGS System is suitable for use in all establishments other than domestic and those directly connected to the public low-voltage power supply network that supplies buildings used for domestic purposes.
Voltage fluctuations / flicker emissions IEC 61000-3-3	Not applicable	The IGS System is suitable for use in all establishments other than domestic and those directly connected to the public low-voltage power supply network that supplies buildings used for domestic purposes.

**NOTE**

The EMISSIONS characteristics of this equipment make it suitable for use in industrial areas and hospitals (CISPR 11 class A). If it is used in a residential environment (for which CISPR 11 class B is normally required) this equipment might not offer adequate protection to radio-frequency communication services. The user might need to take mitigation measures, such as relocating or re-orienting the equipment.

### 3.2.3 Electromagnetic Immunity

#### 3.2.3.1 Electromagnetic Immunity IEC 60601-1-2

The IGS System is intended for use in the electromagnetic environment specified below.

The Customer or the user of the System should assure that it is used in such an environment.

Table 22

Immunity Test	IEC 60601-1-2 Ed2.1 & 3 Test Level	IEC 60601-1-2 Ed4 Test Level (professional healthcare environment)	Compliance Level	Electromagnetic Environment
Electrostatic discharge (ESD) IEC 61000-4-2	+/-6 kV contact +/-8 kV air	+/-8 kV contact +/-15 kV air	+/-6 kV contact +/-8 kV air	Floors are wood, concrete or ceramic tile or floors are covered with synthetic material and the relative humidity is at least 30 %.
Electrical fast transient/burst IEC 61000-4-4	+/-2 kV for power supply lines +/-1 kV for input/output lines 5 kHz burst repetition frequency	+/-2 kV for power supply lines +/-1 kV for input/output lines 100 kHz burst repetition frequency	+/-2 kV for power supply lines +/-1 kV for input/output lines 5 kHz & 100 kHz burst repetition frequency	Mains power quality is that of a typical commercial or hospital environment.
Surge IEC 61000-4-5	+/-1 kV line(s) to lines(s) +/-2 kV line(s) to earth	+/-1 kV line(s) to lines(s) +/-2 kV line(s) to earth	+/-1 kV line(s) to lines(s) +/-2 kV line(s) to earth	Mains power quality is that of a typical commercial or hospital environment.
Voltage dips, short interruptions and voltage variations on power supply input lines IEC 61000-4-11	<5 % $U_T$ (> 95 % dip in $U_T$ ) 0% for 5 sec	0 % $U_T$ ; 250/300 cycle	<5 % $U_T$ (> 95 % dip in $U_T$ ) 0% for 5 sec 0 % $U_T$ ; 250/300 cycle	Mains power quality is that of a typical commercial or hospital environment. If the user of the IGS System requires continued operation during power mains interruptions, it is recommended that the System be powered from an uninterruptible power supply.
Power frequency (50/60 Hz) magnetic field IEC 61000-4-8	3 A/m	30 A/m	30 A/m	Power frequency magnetic fields is at levels characteristic of a typical location in a typical commercial or hospital environment.
Note: $U_T$ is the AC mains voltage prior to application of the test level. 250/300 cycle means 250 periods at 50Hz or 300 periods at 60Hz.				

The IGS System is intended for use in the electromagnetic environment specified below.  
 The Customer or the user of the System should assure that it is used in such an environment.

**Table 23**

Immunity Test	IEC 60601-1-2 Ed2.1 & 3 Test Level	IEC 60601-1-2 Ed4 Test Level (professional health-care environment)	Compliance Level	Electromagnetic Environment
Conducted Radio Frequency IEC 61000-4-6	3 Vrms 150 kHz to 80 MHz	3 Vrms 150 kHz to 80 MHz 6 Vrms in ISM bands <sup>(1)</sup>	$V_1 = 3 \text{ Vrms}$ 150 kHz to 80 MHz 6 Vrms in ISM bands <sup>(1)</sup>	Portable and mobile RF communications equipment is used no closer to any part of the IGS System, including cables, than the recommended separation distance calculated from the equation applicable to the frequency of the transmitter.
Radiated Radio Frequency IEC 61000-4-3	3 V/m 80 MHz to 2.5 GHz	3 V/m 80 MHz to 2.7 GHz	$E_1 = 3 \text{ V/m}^{(4)}$	<p><b>Recommended separation distance:</b>  <math>d = [3.5/V1]\sqrt{P}</math>  <math>d = [3.5/E1]\sqrt{P}</math>, from 80 MHz to 800 MHz  <math>d = [7/E1]\sqrt{P}</math>, from 800 MHz to 2.5 GHz</p> <p>Where <math>P</math> is the maximum output power rating of the transmitter in watts (W) according to the transmitter manufacturer and <math>d</math> is the recommended separation distance in meters (m).</p> <p>Field strengths from fixed RF transmitters, as determined by an electromagnetic site survey <sup>(2)</sup>, are less than the compliance level in each frequency range <sup>(3)</sup>.</p> <p>Interference may occur in the vicinity of equipment marked with the following symbol:  </p>

**NOTE**

(1): The ISM (industrial, scientific and medical) bands between 0,15 MHz and 80 MHz are 6,765 MHz to 6,795 MHz; 13,553 MHz to 13,567 MHz; 26,957 MHz to 27,283 MHz; and 40,66 MHz to 40,70 MHz.

(2): Field strengths from fixed transmitters, such as base stations for cellular telephones and land mobile radios, amateur radio, AM and FM radio broadcast, and TV broadcast cannot be estimated accurately. To assess the electromagnetic environment due to fixed RF transmitters, an electromagnetic site survey should be performed. If the measured field strength exceeds the RF compliance level above, observe the IGS System to verify normal operation in each use location. If abnormal performance is observed, additional measures may be necessary, such as re-orienting or relocating the IGS System.

(3): Over the frequency range 150 kHz to 80 MHz, field strengths are less than 3 V/m.

(4): Refer to Table and Notice below.



**NOTICE**

The IGS System is a Large, Permanently-Installed Medical Equipment for which the simulated operation in an anechoic chamber is not feasible and consequently is exempt from the testing requirement specified by IEC 61000-4-3.

The IGS System has not been tested for radiated RF immunity over the entire frequency range 80 MHz to 6 GHz.

The IGS System has been tested for radiated RF immunity only at selected frequencies. Use nearby of emitters at other frequencies could result in improper operation.

**Table 24 IEC 60601-1-2 Ed2.1 &3 field level & frequencies**

Tested frequencies (MHz)	Field Level (V/m)	Modulation
433.92 (ISM)*	3	80 % AM at 1 kHz rate
915 (ISM)*		
1440		
1750		
1920		
2450 (ISM)*		

**NOTE**

\* Industrial, Scientific and Medical (ISM) radio bands.

**NOTE**

These are guidelines. Actual conditions may vary.

The associated recommended separation distances as per IEC 60601-1-2 Ed2.1 & 3 are listed in [Table 26 on page 130](#).

Additional IEC 60601-1-2 Ed4.0 field level & frequencies - immunity to proximity fields from RF wireless equipment:

**Table 25 IEC 60601-1-2 Ed4.0 field level & frequencies**

Tested frequencies (MHz)	Field Level (V/m)	Modulation
385	27	Pulse modulation (50% duty cycle) - 18 Hz
450	28	Pulse modulation (50% duty cycle) - 18 Hz
710	9	Pulse modulation (50% duty cycle) - 217 Hz
710	9	Pulse modulation (50% duty cycle) - 217 Hz
745	9	Pulse modulation (50% duty cycle) - 217 Hz
780	9	Pulse modulation (50% duty cycle) - 217 Hz
810	28	Pulse modulation (50% duty cycle) - 18 Hz
870	28	Pulse modulation (50% duty cycle) - 18 Hz
930	28	Pulse modulation (50% duty cycle) - 18 Hz
1720	28	Pulse modulation (50% duty cycle) - 217 Hz
1845	28	Pulse modulation (50% duty cycle) - 217 Hz
1970	28	Pulse modulation (50% duty cycle) - 217 Hz
2450 (ISM)*	28	Pulse modulation (50% duty cycle) - 217 Hz
5240	9	Pulse modulation (50% duty cycle) - 217 Hz
5500	9	Pulse modulation (50% duty cycle) - 217 Hz

IEC 60601-1-2 Ed4.0 field level & frequencies continued		
Tested frequencies (MHz)	Field Level (V/m)	Modulation
5785	9	Pulse modulation (50% duty cycle) - 217 Hz
5800 (ISM)*	9	Pulse modulation (50% duty cycle) - 217 Hz

**NOTE**

\* Industrial, Scientific and Medical (ISM) radio bands.

**NOTE**

These are guidelines. Actual conditions may vary.

Equipment used for tests:

- RF signal generator,
- RF power amplifier,
- Transmitting antenna,
- Field sensor,
- Field meter.



PORTABLE RF COMMUNICATIONS EQUIPMENT INCLUDING PERIPHERALS (SUCH AS ANTENNA CABLES AND EXTERNAL ANTENNAS) SHOULD BE USED NO CLOSER THAN 30 CM (12 INCHES) TO ANY PART OF THE IGS SYSTEM INCLUDING CABLES SPECIFIED BY THE MANUFACTURER. OTHERWISE, DEGRADATION OF THE PERFORMANCE OF THIS EQUIPMENT COULD RESULT.

### 3.2.3.2 Recommended Separation Distances for Portable and Mobile RF Communications Equipment IEC 60601-1-2 (Ed2.1 & 3)

Table 26

Frequency of Transmitter	150 KHz to 80 MHz	80 MHz to 800 MHz	800 MHz to 2.5 GHz
Equation	$d = [3.5 / V_1] \sqrt{P}$	$d = [3.5 / E_1] \sqrt{P}$	$d = [7 / E_1] \sqrt{P}$
Rated Power of Transmitter (watts)	Distance (meters)	Distance (meters)	Distance (meters)
10 mW	0.11	0.11	0.22
100 mW	0.37	0.37	0.74
1	1.1	1.1	2.3 (*)
10	3.7	3.7	7.4
100	12	12	23

For transmitters rated at a power not listed above, the DISTANCE can be estimated using the equation in the corresponding column, where P is the power rating of the transmitter in watts (W) according to the transmitter manufacturer.

**NOTE**

These are guidelines. Actual conditions may vary.

### 3.2.4 Limitations Management

Adhering to the distance separation recommended in [Table 26 on page 130](#), between 150 kHz & 2.5 GHz, will reduce disturbances recorded at the image level, but may not eliminate all disturbances. However, when installed and operated as specified herein, the IGS System will maintain its essential performance by continuing to acquire, display, and store diagnostic quality images safely.

For example, a 1W mobile phone (800 MHz to 2.5 GHz carrier frequency) shall be put 2.3 meters (see (\*) [Table 26 on page 130](#)) apart from the IGS System (in order to avoid images interferences risks).

## 3.2.5 Installations Requirements & Environment Control



USE OF ACCESSORIES, TRANSDUCERS AND CABLES OTHER THAN THOSE SPECIFIED OR PROVIDED BY THE MANUFACTURER OF THIS EQUIPMENT COULD RESULT IN INCREASED ELECTROMAGNETIC EMISSIONS OR DECREASED ELECTROMAGNETIC IMMUNITY OF THIS EQUIPMENT AND RESULT IN IMPROPER OPERATION.

Compatibility with HF SURGICAL EQUIPMENT:

The System configurations that could be used in operating room are compatible with HF surgical equipment. During HF surgery, the System shall remain in stand-by mode (no motions or X-Ray acquisition) when the HF surgical equipment is activated.



### NOTICE

In order to minimize interference risks, the following requirements shall apply:

- Electrical equipment may disturb and interfere with System components. The control of the clearing distances from the noise sources is recommended from the HF electrosurgery generator, power supplies converters from nearby monitors or from other close electrical equipment). Refer to respective device manufacturers instructions & recommendations in such cases.
- Electrostatic discharges environment & recommendations:
  - In order to reduce electrostatic discharge interference, install a charge dissipative floor material to avoid electrostatic charge buildup.
  - The relative humidity shall be within the specification defined in [4.1 Humidity, Temperature and Altitude on page 133](#).
  - The dissipative material shall be connected to the room protective earth or equipotential conductor, if applicable.

Page intentionally left blank

# Chapter 4 Environmental Requirements

## 4.1 Humidity, Temperature and Altitude

### 4.1.1 Humidity

**Table 27 Relative Humidity (non- condensing)**

	MIN	MAX
Exam Room	30%	70%
Control Room	30%	75%
Technical Room	30%	75%

### 4.1.2 Temperature and Altitude

The system is certified for use up to 3000 m.

Above 2000 m, the thermal dissipation is reduced because the air pressure is lower. Therefore, a temperature derating shall be applied for the Technical Room as defined in the table below.

**Table 28 Exam Room and Control Room - Temperature**

	MIN	MAX	RECOMMENDED
Exam Room	+15°C (+59°F)	+32°C (+90°F)	Design for Patient/ Operator comfort
Control Room	+15°C (+59°F)	+35°C (+95°F)	Design for Operator comfort

**Table 29 Technical Room - Temperature**

	Temperature up to 2000 m			Temperature above 2000 m		
	MIN	MAX	RECOMMENDED	MIN	MAX	RECOMMENDED
Technical Room (with 1 kVA)	+10°C (+50°F)	+30°C (+86°F)	+20°C (+68°F)	+10°C (+50°F)	+20°C (+68°F)	+20°C (+68°F)
Technical Room (with 8 kVA or the Fluoro UPS)	+15°C (+59°F)	+25°C (+77°F)	+20°C (+68°F)	+15°C (+59°F)	+20°C (+68°F)	+20°C (+68°F)

**NOTE**

For the systems that are planned to be installed at the second floor or above, the temperature and humidity of the rooms that are directly below the gantry room should be the same as the Exam Room requirement.

Differences in temperature or humidity between the Exam room and the room located below will cause condensation within the gantry or patient table, resulting in part failure or rust. Failure to do so will void the equipment warranty. Avoid above grade installations if the temperature is high in the area below the cables entrance of the gantry or table.

## 4.2 Heat Output

In the table:

- Moderate Use corresponds to 8 cases per 10 hours,
- Typical Use corresponds to 11 cases per 10 hours,
- Maximum Use is during the case.

**Table 30**

		HEAT OUTPUT							
		Stand by		Moderate Use		Typical Use		Maximum Use	
Room	Core System	kW	BTU/hr	kW	BTU/hr	kW	BTU/hr	kW	BTU/hr
Exam Room	Gantry and Table	0.41	1,399	0.55	1,877	0.89	3,037	1.62	5,528
	6 19" monitors on suspension or	0.30	1,024	0.30	1,024	0.30	1,024	0.30	1,024
	LDM suspension with 2 backups	0.50	1,706	0.50	1,706	0.50	1,706	0.50	1,706
	Typical Injector	0.09	307	0.09	307	0.09	307	0.09	307
Control Room	DL console and Live monitor	0.10	341	0.10	341	0.10	341	0.10	341
Technical Room	C-FRT Cabinet	0.70	2,388	0.70	2,388	0.70	2,388	0.70	2,388
	PDU	0.40	1,365	0.40	1,365	0.40	1,365	0.40	1,365
	Tube Chiller	2.53	8,633	4.49	15,321	5.49	18,733	6.93	23,646
	Detector Conditioner	0.21	717	0.21	717	0.21	717	0.21	717
	UPS 1 kVA	0.15	500	0.15	500	0.15	500	0.15	500
	UPS 8 kVA	0.52	1,760	0.52	1,760	0.52	1,760	0.52	1,760
	Fluoro UPS	2.14	7,302	2.14	7,302	2.14	7,302	2.14	7,302

continued									
		HEAT OUTPUT							
		Stand by		Moderate Use		Typical Use		Maximum Use	
Room	Core System	kW	BTU/hr	kW	BTU/hr	kW	BTU/hr	kW	BTU/hr
	Total for Core System with the 1 kVA UPS	5.39	18,380	7.49	25,545	8.83	30,117	11.00	37,522
	Total for Core System with the 8 kVA UPS	5.76	19,640	7.86	26,805	9.20	31,377	11.37	38,782
	Total for Core System with the Fluoro UPS	7.38	25,182	9.48	32,347	10.82	36,919	12.99	44,324

## 4.3 Acoustic Specifications

- Less than 50 dB (A) at 1 meter for Gantry.
- Limited to 50 dB (A) at 1 meter for Omega IV Table and Omega V Table.
- Limited to 58 dB (A) at 1 meter for Innova<sup>IQ</sup> Table and Innova<sup>IQ</sup> OR Table.
- Limited to 59 dB (A) at 1 meter for C-FRT Cabinet and NPA PDU.
- Limited to 60 dB (A) at 1 meter for the Tube Chiller.
- Limited to 52 dB (A) (background of 35 dB (A)) at 1 meter for Detector Conditioner.
- Limited to 39 dB (A) at 1 meter for UPS 8 kVA.
- Less than 60 dB (A) at 1 meter for the Fluoro UPS.
- less than 55 dB (A) at 20 degrees Celsius, measured in the operators head position, 20 cm in front of the keyboard's right corner, at 1.30 m above the floor, and in a distance of 1 meter at all four sides.

## 4.4 Room Light

### 4.4.1 Requirements for Lighting

Requirement for lighting concern the following, general, light-technique characteristics:

- Illuminator level.
- Lighting distribution.
- Preventing the operator from being dazzled by the light (by direct light sources or by reflection on bright objects).

The Illumination level must be compliant with established lighting technical rules and be as constant as possible.

Technical Room, Exam Room and Control Room shall be provided with appropriate lighting in the maintenance area (maintenance area to be considered are service workplaces). It corresponds to service areas as defined for any of the product components.

The minimum required average luminance  $E_m$  shall be of 500 lux and minimum color rendering factor  $R_a$  of 80 as per IEC/EN 12464-1 (Light and lighting. Lighting of work places. Indoor work places: Illumination requirements for indoor workplaces corresponding to assembly of medium size electrical components, e.g. control panel) for the electrical industry).

#### 4.4.2 Windows and Curtains

When the Exam Room has a window with an aperture outside of the controlled light area (day light, other...) a curtain has to maintain the light intensity under a limit fixed to 150 lux.

#### NOTE

In Germany: Ambient luminance of 100 lux maximum is required to maintain Exam Room class 2 according to DIN 6868-157.

#### 4.4.3 Surgical Lights



If a surgical light is installed by the customer, it has to be powered from an independent power supply (provided by the hospital not by the System).

# Chapter 5 Electrical Requirements

## 5.1 System Electrical Ratings

### 5.1.1 Electrical Ratings

Table 31

Nominal voltage	Frequency	Power consumption			Type of power input	
		Long time	Momentary	Peak	With 1 & 8 kVA UPS	With 20 kVA UPS
380 V	50 Hz or 60 Hz	18 kVA	100 kVA	150 kVA	3~	3N~
400 V						
415 V						
480V	60 Hz					

Long time rating is measured in fluoroscopy mode at 30 fps, 120 kV, 89 mA, 10 ms.

Momentary rating is measured in record DSA mode at 7.5 fps, 125 kV, 640 mA, 50 ms.

For the rating of the external devices not powered by the system (AW, injector, and so on), refer to the OEM documentation.

Max Line Impedance for the line phase to phase at the entry of the X-rays Generator in C-FRT Cabinet (from IEC 601-2-7):

Table 32

V	380	400	415	480
$\Omega$	0.09	0.096	0.102	0.12

### 5.1.2 Additional Transformer characteristics

If a transformer is needed to power the system (e.g. when the mains is not within the nominal value of the system, or if an insulation from other devices is needed), it shall have the following characteristics:

- 150 kVA minimum for input voltage of 380 V and 400 V.
- 100 kVA minimum for input voltage of 415 V and 480 V.
- The transformer impedance shall be 4.5 % or less (this parameter is also called %Z or short circuit voltage).

### 5.1.3 Additional Full UPS

If it is required to power continuously the system in record mode during power failure, a 150 kVA UPS can be used in front of the system. Such an UPS will provide to the customer about 10 minutes of autonomy. This UPS comes in addition to the UPS provided with the system.

## 5.2 Power Distribution Schematics

Information below specifies the cables provided by GE and the cables provided by the Hospital. Refer to [MDP Cabling Requirements on page 144](#).

### 5.2.1 System with 1 or 8 kVA UPS

Figure 112 Power Distribution with 1 kVA UPS or 8 kVA UPS

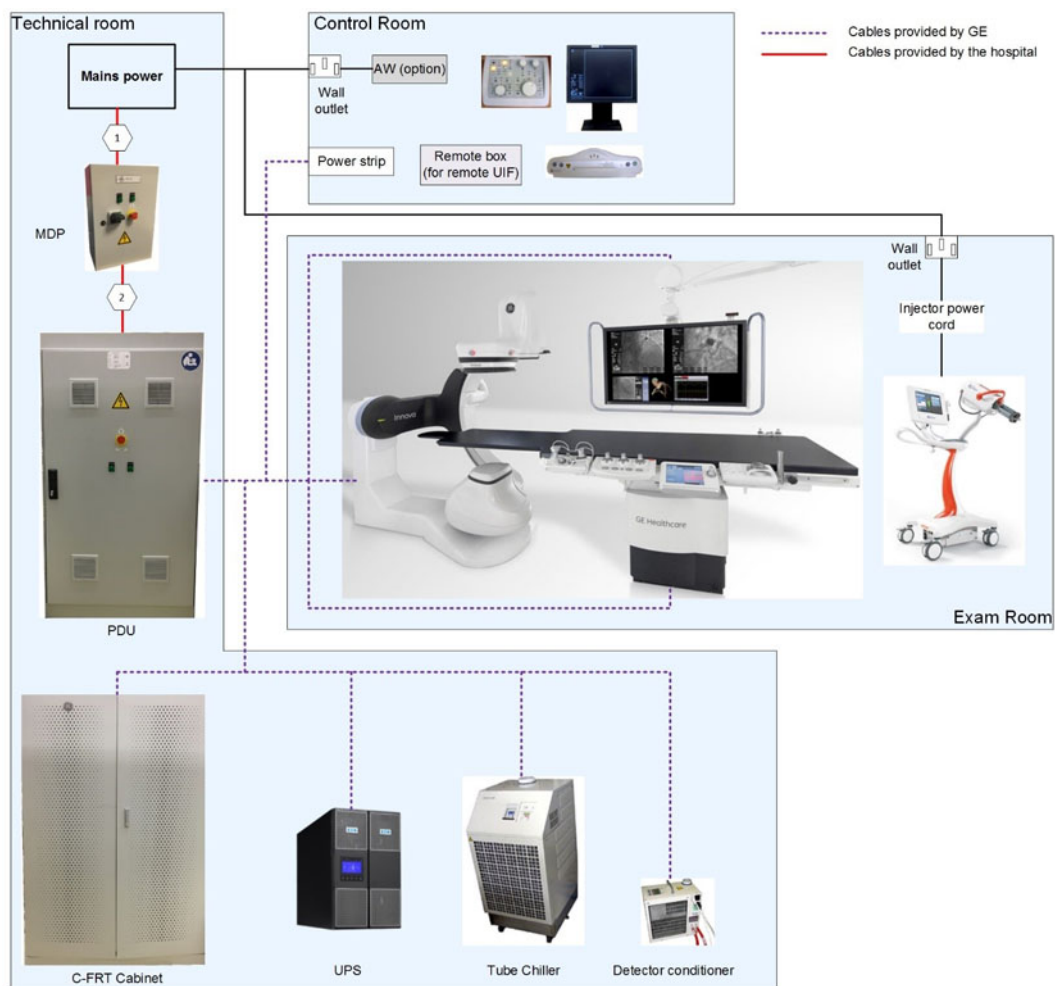

**NOTE**

UPS 1 kVA is only provided with System with Omega Table.

## 5.2.2 System with Fluoro UPS

Figure 113 Power Distribution with Fluoro UPS

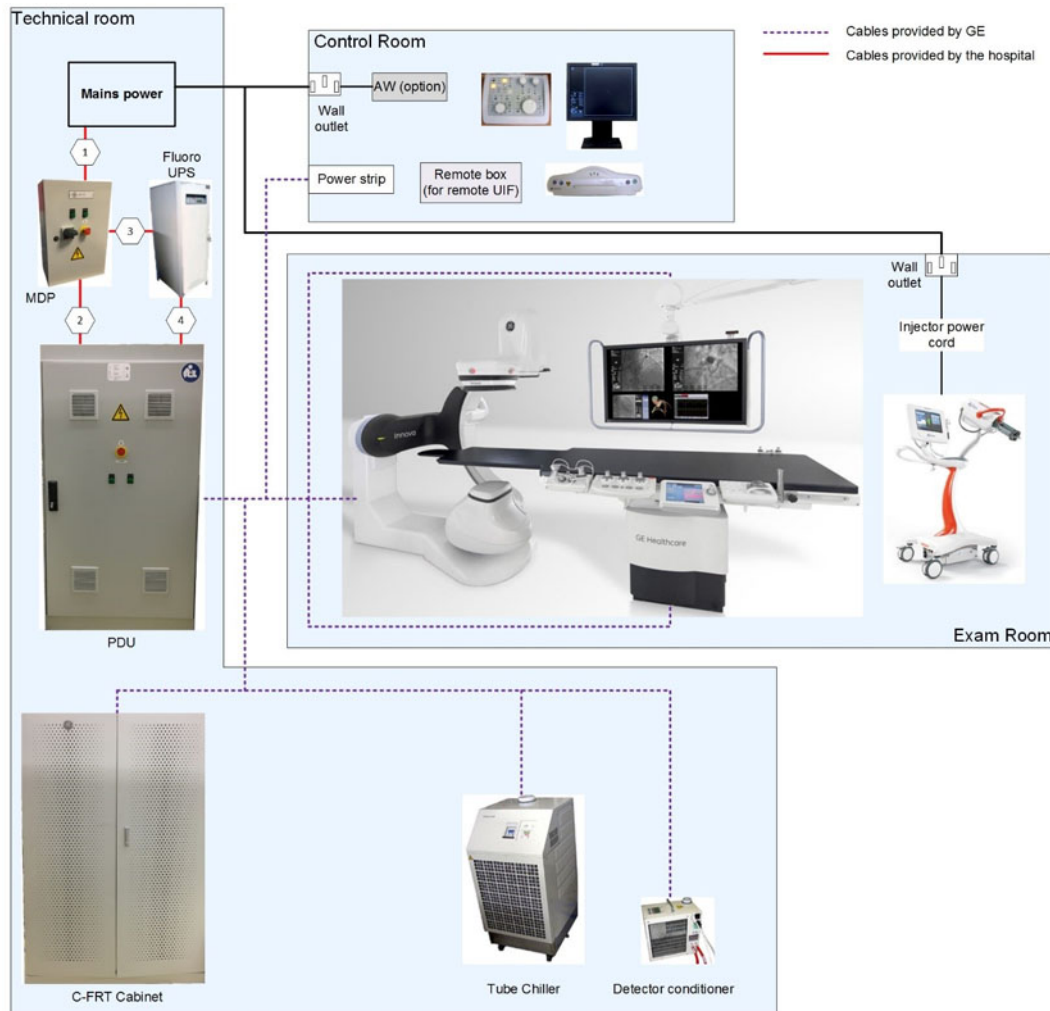

## 5.2.3 System with Fluoro UPS and IT Electrical Network

The Fluoro UPS requires a Neutral line connected to the Protective Earth. For hospitals with an IT Electrical Network, a transformer is required with Delta-Wye or Delta-Star connection.

This transformer shall be provided by the customer; its characteristics shall be:

- 30 kVA minimum.
- Secondary star 3 Ph+N.
- The power distribution shall be of TNS type with the Neutral grounded.
- The transformer impedance shall be 4.5% or less (this parameter is also called %Z or short circuit voltage).

It is also the responsibility of the customer to provide:

- The box of the transformer to avoid access to live parts according to local regulations.

- The current protections at the output of the transformer, fuses or breaker, as per local regulations. The suggested rating is 50A.

Figure 114 Power Distribution with Fluoro UPS and IT Electrical Network

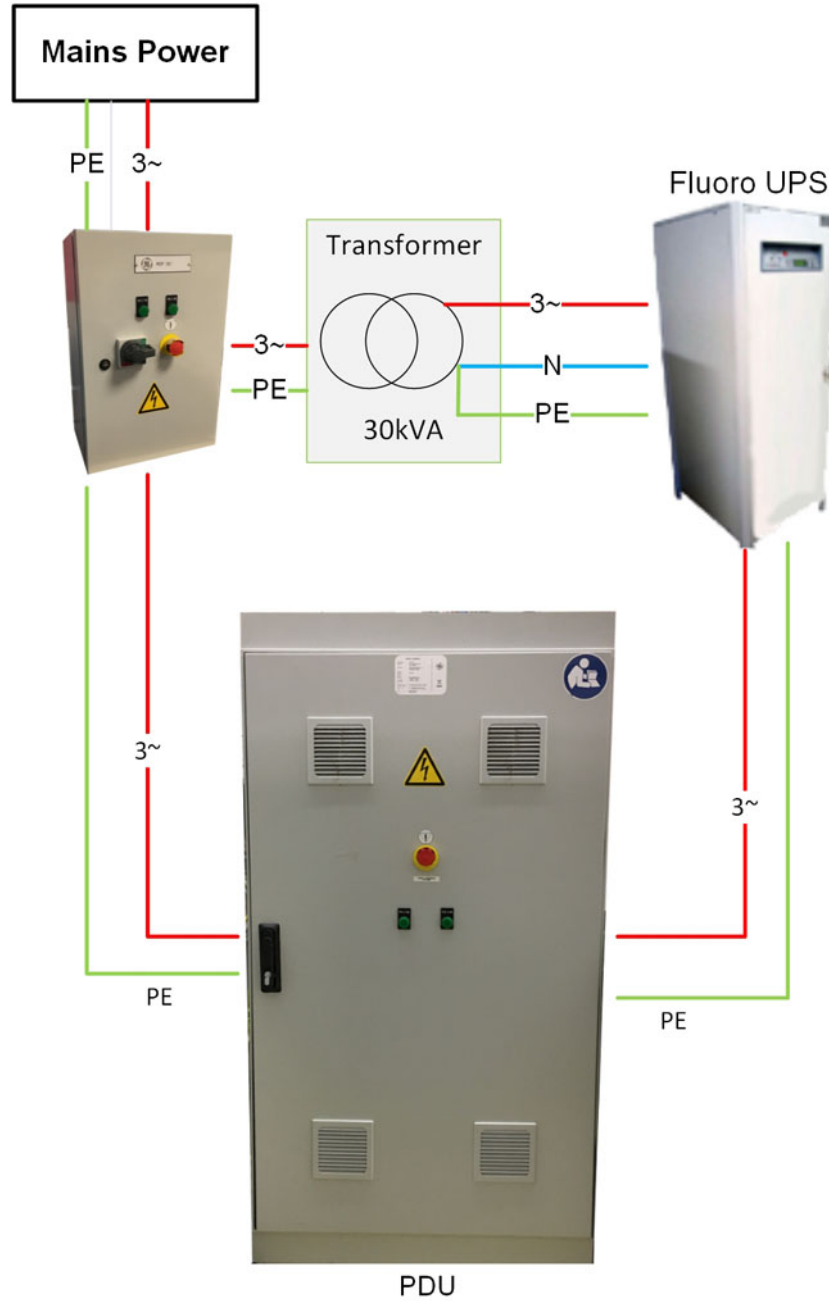

## 5.3 Mains Disconnect Panel

### 5.3.1 General Information

#### 5.3.1.1 Introduction

The Mains Disconnect Panel (MDP) is the electric panel which is the interface between the Hospital mains and the System. It allows the power connections from the hospital power to the input of the PDU of the system and to the Fluoro UPS if present. It provides the LOTO (lock out – tag out) functions that allows safe service operation, and is part of the EPO (Emergency Power Off) function.

As the requirements applicable to electric panels vary from a country to another, information below lists the GE mandatory requirements to provide safe system operation and the installation precautions, in addition to the local regulatory requirements.

Information given shall allow the Customer to build the MDP in compliance with GE's rules. In addition, the following MDP can be ordered through the GE accessory catalog:

- MDP CE (P/N 5779988), certified IEC 61439-1 and CCC,
- MDP UL (P/N 5779987), certified UL508A for USA.



**The Customer MDP is not covered by the GEHC product certification. The association of the Innova™ System and the Customer MDP is not covered by the GEHC product certification.**

**GE specifically disclaims any and all liability arising out of or relating to the use or performance of the MDP and the cables in the scope of Innova™ IGS 5 Pre-Installation Manual, including, and without limitation, any liability or claims relating to patient injury, death, or the reliability of such MDP.**

**The mechanical and electrical installation of the MDP is fully under the customer and the installer responsibility.**

**The customer is responsible for ensuring that all requirements from the Innova™ IGS 5 Pre-Installation Manual are met.**

#### 5.3.1.2 Pre-Installation

It is the customer responsibility to ensure that the MDP and its input and output cables are installed prior to the GE equipment (PDU, other cabinets, FUPS option, etc.) to ensure that standard GE Service Process can be followed during the System installation. The connection of the MDP to the GE equipment shall only be made in presence of a GE Service representative.

It is recommended that the vendor contacts GE Service representative and reviews the site planning details before the MDP is installed.

#### NOTE

GE will not be responsible for any delay in installation if the MDP is not mounted and its cables not routed before GE parts arrive on site.

### 5.3.1.3 Spare Parts

The customer is responsible for providing and replacing any part of MDP.

## 5.3.2 Mandatory Construction Requirements

### 5.3.2.1 Input Power

The MDP shall be functional within one the following input voltage and frequency ranges from the Hospital mains:

- Voltage range for systems without the Fluoro UPS:
  - 380 V +/-10% 3~, 50 Hz or 60 Hz +/-3 Hz
  - 400 V +/-10% 3~, 50 Hz or 60 Hz +/-3 Hz
  - 415 V +/-10% 3~, 50 Hz or 60 Hz +/-3 Hz
  - 480 V +/-10% 3~, 60 Hz +/-3 Hz
- Voltage range for systems with the Fluoro UPS:
  - 380 V +/-10% 3N~, 50 Hz or 60 Hz +/-3 Hz
  - 400 V +/-10% 3N~, 50 Hz or 60 Hz +/-3 Hz
  - 415 V +/-10% 3N~, 50 Hz or 60 Hz +/-3 Hz
  - 480 V +/-10% 3N~, 60 Hz +/-3 Hz

### 5.3.2.2 Breakers

The MDP shall provide a main breaker at its input, its specifications shall be:

- Current Rating: 100 A.
- It shall be capable of withstanding an inrush current of 2000 A for 10 ms.
- The voltage rating shall be the MDP nominal input line voltage +10%: i.e., 380 V + 10%, 400 V + 10%, 415 V + 10% or 480 V +10%.
- The frequency range shall be adapted to the input line frequency i.e., 50 Hz +/-3 Hz or 60 Hz +/-3 Hz.
- The Short Circuit Current Rating (SCCR) shall be adapted to the input line source short circuit capacity.

This command of this breaker shall be accessible from the outside of the MDP, in order to be able to rearm it without opening the MDP after an emergency power off.

For systems with the FUPS, the MDP shall provide a second breaker for protection of the FUPS input. Its specifications shall be:

- 3 poles type
- Voltage rating: same as the MDP main breaker
- Frequency range: same as the MDP main breaker
- Current Rating: 50 A
- Short Circuit Current Rating (SCCR): 50 kA.

For systems with the Fluoro UPS, the breaker for the FUPS input protection shall be powered by the MDP main breaker.

### 5.3.2.3 Terminal Blocks

The MDP shall have an input mains terminal block rated in accordance with the hospital input voltage. It shall be capable of holding minimum 35 mm<sup>2</sup> cable for the 3 phases, protective Earth and neutral (only for systems with the Fluoro UPS).

The MDP shall provide an output terminal block rated in accordance with the MDP input voltage to connect the output from the MDP main breaker to the system. This terminal block shall be capable of holding minimum 35 mm<sup>2</sup> cable for the 3 phases.

For systems with the Fluoro UPS, the MDP shall have a terminal block to connect an input neutral from the mains and an output neutral to the Fluoro UPS, and it shall have an output terminal block rated to the hospital input voltage to connect the mains input power from the MDP to the FUPS. This terminal block shall be capable of holding minimum 10 mm<sup>2</sup> cable for the 3 phases and neutral.

### 5.3.2.4 Protective Earth

The MDP shall have a ground bar / ground terminal to connect the protective Earth cables:

- from the hospital mains,
- to the system,
- to the FUPS (if present).

### 5.3.2.5 Indicators

The MDP shall have lights to indicate the presence of voltage. The presence of voltage on each input line shall be indicated by at least having lamps between Line1-Line2 and Line2-Line3. The recommended color for these lamps is green.

## 5.3.3 Mandatory EPO Requirements

The MDP shall provide an emergency power off (EPO) button on its front.

The EPO button shall not be of momentary type.

The EPO button shall have 2 NC contacts:

- one NC contact is to trip the MDP input breaker,
- the other NC contact is to activate the UPS EPO input (1 kVA or 8 kVA or FUPS) to turn off the UPS output (this connection is done inside the PDU).

The MDP shall provide a terminal block to connect external cables to the 2 NC contacts of the MDP EPO.

When the MDP EPO or the PDU EPO is pressed, the MDP shall not provide any output voltage without any additional action on the EPO buttons and on the MDP input breaker.

The EPO button shall be protected against accidental activation, in order to prevent from accidental power OFF as shown below or equivalent.

**Figure 115 EPO Button**



### 5.3.4 Mandatory LOTO Requirements

The MDP shall provide means of disconnecting the mains power from the system, with LOTO capability to ensure safe service operation. It can be done by the input breaker if it has disconnecting capability, or by a separate disconnection device.

An operator should be able to apply LOTO without opening the MDP box. When a LOTO device is installed on the MDP input breaker or on the disconnecting device, there shall be no voltage at the output of the MDP.

### 5.3.5 Cabling Requirements

It is the customer's responsibility to ensure that the electrical installation is compliant with local regulations, such as NFPA99 (Health Care Facilities Code) or 60364-7-710 (Requirements for special installations or locations - Medical locations).

The power supply and ground cables shall be dedicated to the system. They must not be used to supply other systems. Power supply and ground cables shall be kept separated from other room System cables and must be connected to the same distribution panel. They must run near one to the other.

The power cables, ground cables and EPO cables provided by the customer shall be compliant with local regulations (e.g. UL, NFPA 70, CSA, IEC, CCC).

### 5.3.5.1 Power Cables

The minimum gauge of the power cables at the MDP input and between the MDP and the PDU shall be 35 mm<sup>2</sup> / AWG2 (cables # 1 and # 2 on [Figure 112 on page 138](#) and [Figure 113 on page 139](#)).

The length of the cable between MDP and PDU (cable # 2) shall not be more than 6 meters. This cable shall be copper cable and cable insulation temperature shall be 90°C.

Refer to the impedance definition in [5.1 System Electrical Ratings on page 137](#).

The minimum gauge of the power cables from the MDP to the FUPS and from the FUPS to the PDU shall be 10 mm<sup>2</sup> / AWG6 (cables # 3 and # 4 on [Figure 113 on page 139](#)).

The insulation temperature of these power cables shall be 90°C minimum.

### 5.3.5.2 Protective Earth Cables

To avoid risk of electric shock, this equipment must only be connected to a mains power supply with Protective Earth.

The gauge and type of the protective Earth cables (cables #1, #2, #3 and #4) shall be the same as the MDP's input power cables.

### 5.3.5.3 EPO Cable

The hospital shall provide an EPO cable between the MDP and the PDU; its minimum gauge shall be 1 mm<sup>2</sup> and shall be in accordance with the rating of the fuse F2 of the MDP.

## 5.3.6 Mandatory Labeling Requirements

The input mains terminal block and the output terminal blocks of the MDP shall be labeled to indicate the 3 lines as shown below or equivalent:

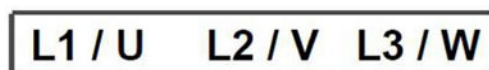

For systems with the Fluoro UPS, the MDP input neutral terminal block and the neutral output terminal block to the Fluoro UPS shall be labelled with the IEC 60445 symbol as shown below or equivalent:

**N**

The ground bar shall be marked with the IEC 60417-5019 symbol as shown below:



### 5.3.7 Other Mandatory Requirements

The MDP and the external cables shall be compliant to all applicable local regulations, in particular to the standards applicable to Industrial Control Panels or Low-voltage switch gear and control gear assemblies, such as UL508A for USA or IEC 61439-1 for Europe.

The MDP enclosure shall be grounded if its enclosure is metallic, and there shall be no access to hazardous voltages. The enclosure shall provide enough rigidity to avoid hazardous situations in case of shock or impact and shall be designed in accordance with the local regulations.

Local regulation may require the MDP to have a door interlock mechanism to prevent from opening the door when the main breaker is on.

The MDP shall be provided with a LOTO procedure.



## 5.3.8.2 Minimum Components Specifications for the CE MDP

Table 33

Component	Label (refer to Figure 116 on page 147)	Rating
Input Circuit Breaker	CB1	4 Pole, 100A, 50 kA, Vin + 10% 50 Hz or 60 Hz 2000 A inrush current withstand capability for at least 10 ms
Circuit Breaker	CB2	50 A, 50 kA, Vin+ 10%, 50 Hz or 60 Hz
Fuse	F1	2A Time delay, Vin+10% Based on Green indicator lights power ratings
Fuse	F2	2A, 24 VAC+10% Based on transformer power rating and transformer load current rating
Fuse	F3	1A Time delay, Vin+10% Based on transformer power rating and transformer input current
Time delay relay	T2	24 VAC+10% Shall have 1 NO contact Time delay setting shall be min 2 Sec
Auxiliary relay	R1	24 VAC+10% Shall have 1 NC contact
Shunt Trip	ST	24 VAC+10% Shunt trip opens the MDP input main breaker when the shunt trip is energized
2 Pilot lights Green	-	Vin+10%, 50 Hz or 60 Hz
Transformer	TR1	Power rating: 50 VA or Based on power ratings of components used at transformer output Input: 380 VAC or 400 VAC or 415 VAC Output: 24V Frequency: 50 or 60 Hz Double insulation as per standard IEC61558 Sum of power ratings of R1, shunt trip and timer shall be less than transformer power rating

continued		
Component	Label (refer to Figure 116 on page 147)	Rating
EPO	-	Mushroom button with 2 NC contacts Rated for 24 VAC, 50 mA
Cable for MDP internal Control circuitry	-	Min 1 mm <sup>2</sup> and in accordance with the fuses rating

### 5.3.8.3 Recommended UL Schematics

Figure 118 UL MDP - Power and Control

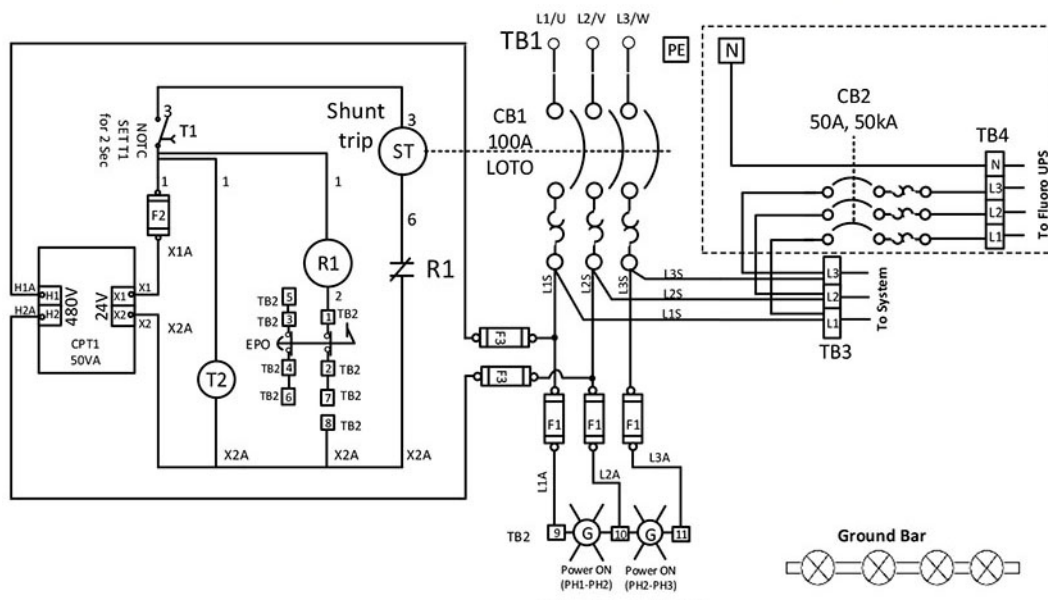

**NOTE**

- Neutral is not required by Imaging system.
- Neutral is required when Fluoro UPS is used.

Figure 119 UL MDP - I/O Interfaces

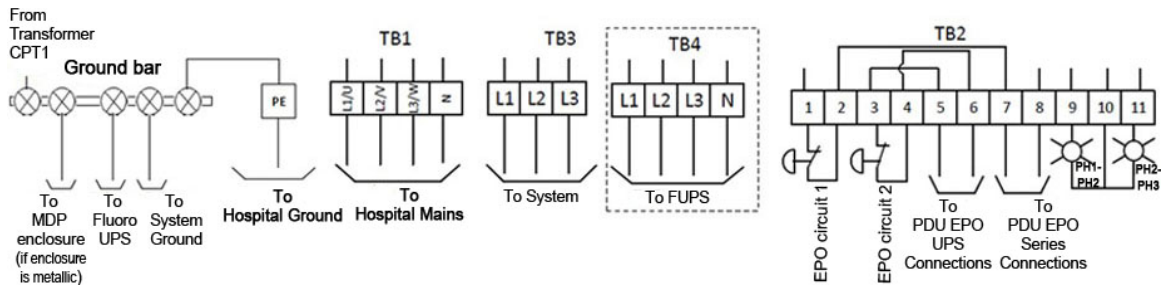

### 5.3.8.4 Minimum Components Specifications for the UL MDP

Table 34

Component	Label (refer to <a href="#">Figure 118</a> on <a href="#">page 149</a> )	Rating
Input Circuit Breaker	CB1	3 Pole, 100 A, 50 kA, 480 VAC+10% 60 Hz 2000 A inrush current withstand capability for at least 10 ms
Circuit Breaker	CB2	50 A, 50 kA, 480 VAC+10% 60 Hz
Fuse	F1	2A Time delay, 480 VAC+10% Based on Green indicator lights power ratings
Fuse	F2	2A, 24 VAC+10% Based on transformer power rating and transformer load current rating
Fuse	F3	1A Time delay, 480 VAC+10% Based on transformer power rating and transformer input current
Time delay relay	T2	24 VAC+10% Shall have 1 NO contact Time delay setting shall be min 2 s
Auxiliary relay	R1	24 VAC+10% Shall have 1 NC contact

continued		
Component	Label (refer to Figure 118 on page 149)	Rating
Shunt Trip	ST	24 VAC+10% Shunt trip shall open the MDP input breaker when shunt trip is energized
2 Pilot lights Green	PH1-PH2 PH2-PH3	480 VAC +10%
Transformer	CP T1	Power rating: 50 VA or Based on power ratings of components used at transformer output Input: 480 VAC Output: 24 VAC Frequency: 60 Hz +/-3 Hz Double insulation as per UL 5085-1 standard Sum of power ratings of R1, shunt trip and timer shall be less than transformer power rating
EPO	-	Mushroom button with 2 NC contacts Rated for 24 VAC, 50 mA
Cable for MDP internal Control circuitry	-	Min AWG16 and in accordance with the fuses rating

## 5.3.9 Checklist

The following checklist shall be filled and given to the Field Engineer before connecting the MDP to the system.

**Table 35**

Test	Expected Result	OK / NOK
Functional Tests		
Initial state: the MDP main breaker is off, power is available at its input. A jumper is installed between TB2 7 & 8 Turn on the MDP main breaker.	The indicator lights on MDP front panel are ON.	
	The voltage at TB3 is the same as the MDP input voltage.	
	For systems with the FUPS, the voltage at TB4 is the same as the MDP input voltage.	
Press the EPO push button on MDP front panel.	The indicator lights on the MDP front panel are turned off.	
	The MDP main breaker is opened.	

continued		
Test	Expected Result	OK / NOK
	There is no voltage at TB3.	
	For systems with the FUPS, there is no voltage at TB4.	
	The dry contact between TB2 5 & 6 is open.	
Check it is possible to apply the LOTO on the MDP input breaker or on the disconnecting device.	It is possible to apply the LOTO on the MDP input breaker or on the disconnecting device.	
Documentation		
Check a LOTO procedure is provided with the MDP.	The LOTO procedure is present.	
Components Ratings		
Check that the components ratings are compliant with the requirements of <a href="#">Minimum Components Specifications for the CE MDP on page 148</a> or <a href="#">Minimum Components Specifications for the UL MDP on page 150</a> .	The components ratings are compliant with the requirements of <a href="#">Minimum Components Specifications for the CE MDP on page 148</a> or <a href="#">Minimum Components Specifications for the UL MDP on page 150</a> .	

## 5.4 External Interfaces

### 5.4.1 Emergency Power Off (EPO)

The PDU is provided with an EPO button on its front panel and provides the connection for additional EPO buttons (in Exam Room or Control Room).

The customer is responsible for the procurement, delivery and installation of the cables and EPO buttons. The EPO buttons shall be "Push to activate - Push to release" type, 2 contacts Normally Closed, compatible with 24 V AC and in accordance with the MDP transformer rating. The maximum length of the cables shall be 24 m, the recommended diameter is AWG14/2 mm<sup>2</sup>.

The EPO buttons shall be protected from accidental activation.

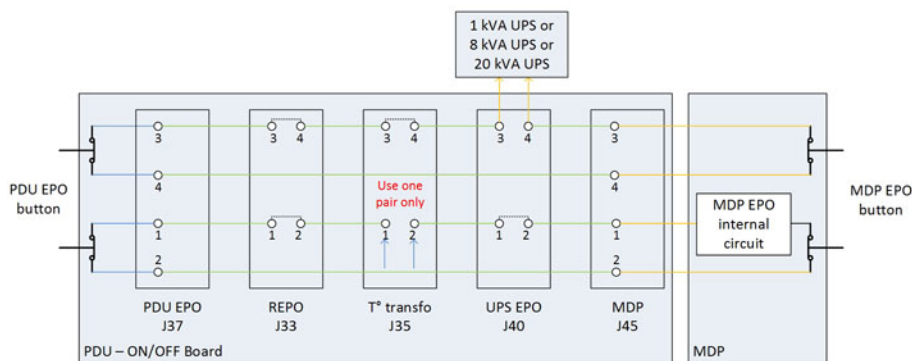

**NOTE**

J35 connection:

- UPS 1 kVA: pair 1, 2 connected to Transformer EPO output, pair 3, 4 is shorted.
- UPS 8 kVA: pair 1, 2 connected to Transformer EPO output, pair 3, 4 is shorted.
- UPS 20 kVA (Fluoro UPS): pair 3, 4 connected to Transformer EPO output, pair 1, 2 is shorted.

**5.4.2 X-Ray ON lights****NOTICE**

The X-Ray ON lamp must be installed in the Exam Room in conformity to the standard IEC/EN 60601-2-43. The X-Ray ON lamp shall be visible by the operator in all the locations defined for the personnel who may receive scattered radiation.

The System provides a dry contact to trigger a low voltage relay (24 V max) that drives the X-Ray ON lights. The Customer is responsible for the procurement, delivery and installation of the power supplies, relay, cables and the X-Ray ON lights.

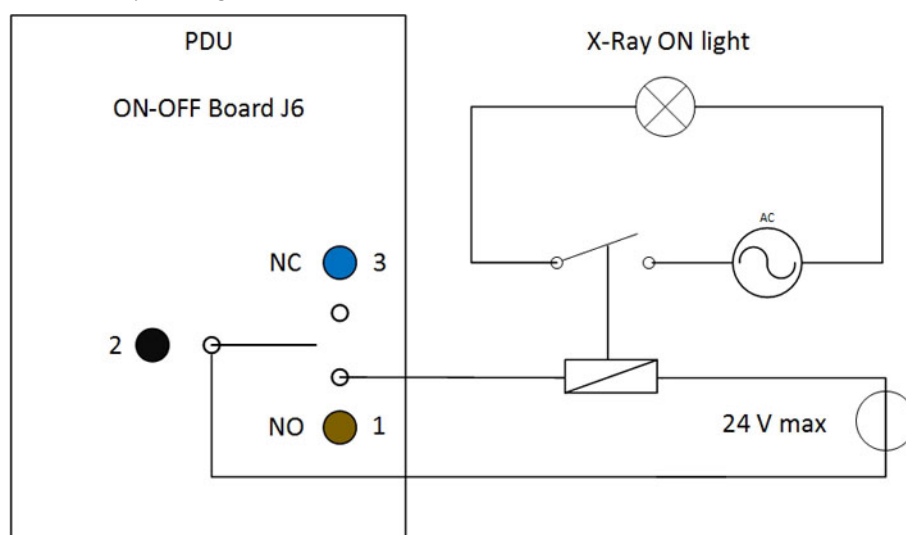

The cables are connected to the PDU on an open contact. The diameter of the cables shall be 2 mm<sup>2</sup> maximum.

**5.4.3 System ON light**

The System provides a dry contact to trigger a low voltage relay (24 V max) that can drive a System ON light. The Customer is responsible for the procurement, delivery and installation of the power supplies, relay, cables and the System ON light.

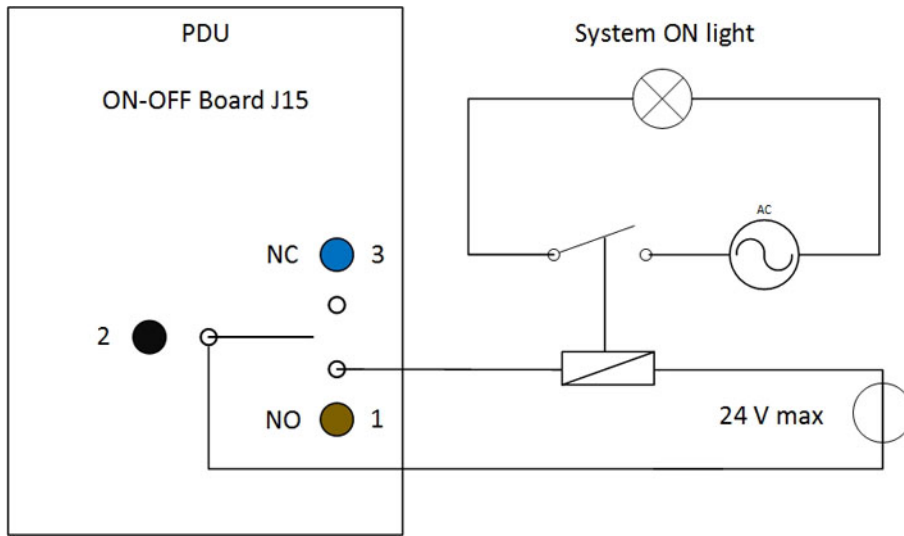

The cables are connected to the PDU on an open contact. The diameter of the cables shall be 2 mm<sup>2</sup> maximum.

#### 5.4.4 Room lights

The System provides a dry contact to trigger a low voltage relay (24 V max) that can drive the Exam Room lights. The Customer is responsible for the procurement, delivery and installation of the power supplies, relay, cables and the room lights.

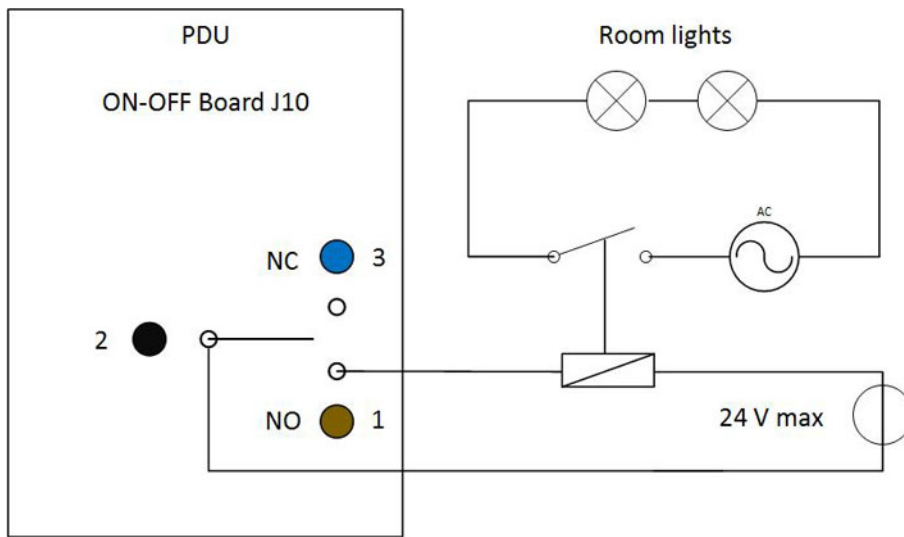

The cables are connected to the PDU on an open contact. The diameter of the cables shall be 2 mm<sup>2</sup> maximum.

#### 5.4.5 Room door interlock

The system provides a room door interlock that can prevent X-Ray emission when the door is open. The IEC 60601-2-43 requires not to install door interlocks. It is the responsibility of the installer to verify that the connection of this interlock is not in contradiction with local regulation. In case of conflict, the local regulation shall prevail.

This switch shall be closed when the door is closed, it shall be compatible with 24 V DC.

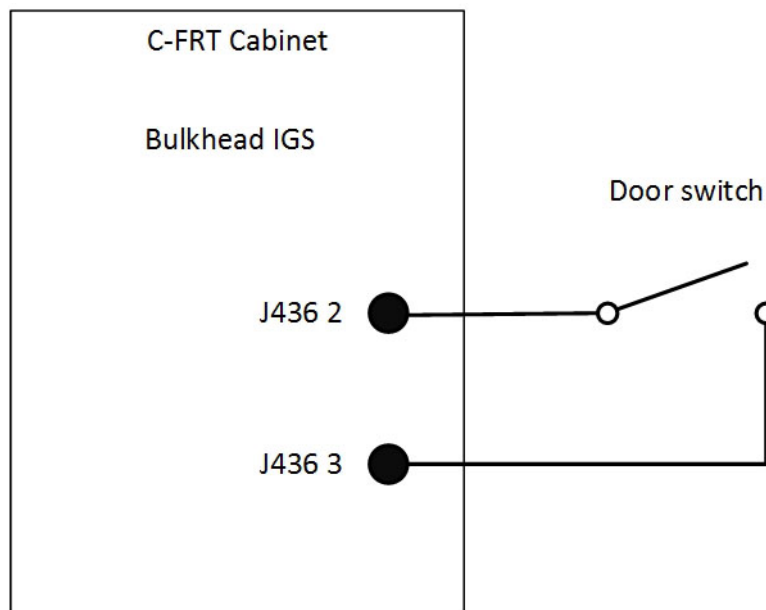

To disable the door interlock: the pins 2 and 3 from J436 shall be shorted. The diameter of the cables connected to the cabinet shall be 2 mm<sup>2</sup> maximum.

#### 5.4.6 Video distribution

The system can provide a DVI output (1280 x 1024, 60 Hz) of its 3 displays (live, roadmap and review). Only 4 streams of each display can be provided (included the images displayed on the LDM).

With the LDM option, a 2MP copy of the LDM image (DVI 1920 x 1080, 60 Hz) can be provided as an option.

These video links are optical cables and their length is 36 m.

#### 5.4.7 Other options

**(For USA only)** A purchasable option I-sense (catalog number E4504B) allows the monitoring of the hospital main power line. It is recommended to install this option everywhere RMS and waveform variation events can impact the standard behavior of the system. I-sense is connected to each phase conductor and the ground. An analog telephone line also needs to be line to I-sense.

## 5.5 System Cable Information

### 5.5.1 Physical Runs

#### 5.5.1.1 Physical Run Synoptic

Figure 120 Interconnection Length - System with 1 kVA UPS or 8 kVA UPS

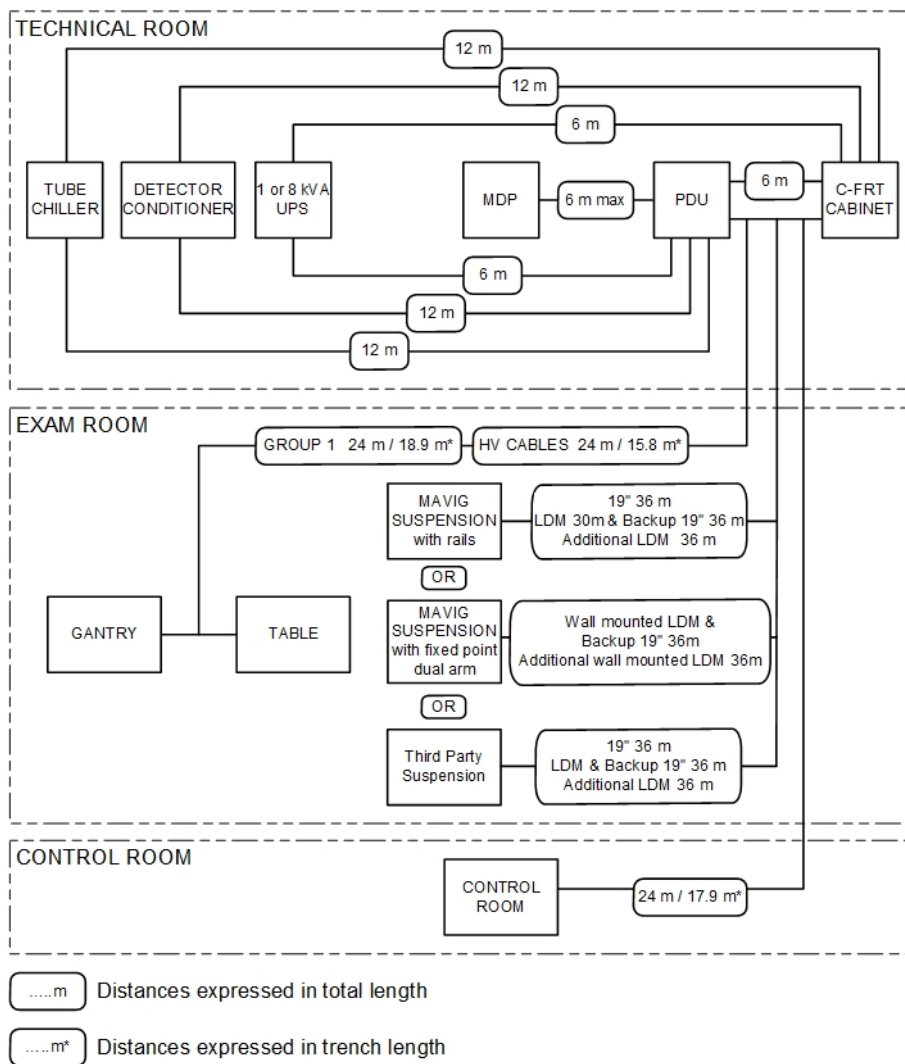

**NOTE**

1 kVA UPS is only provided with Omega Table.

Figure 121 Interconnection Length - System with 20 kVA UPS (Fluoro UPS)

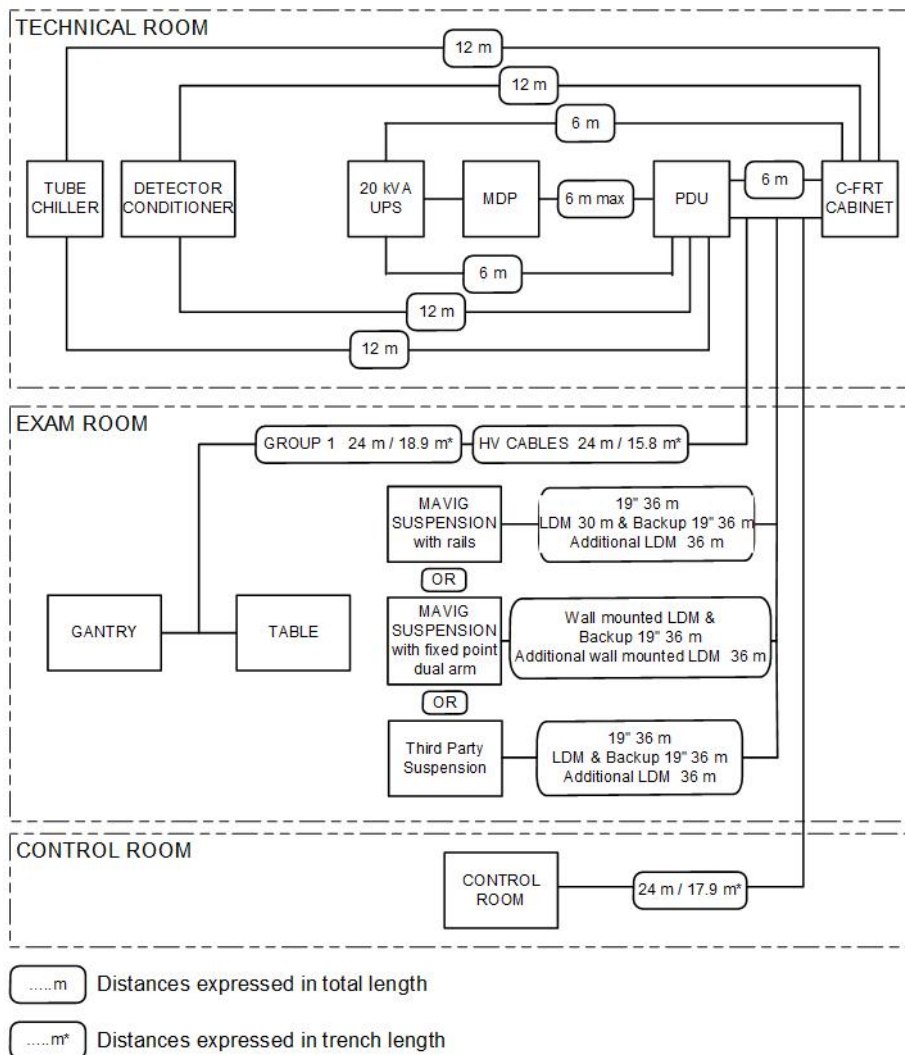

### 5.5.1.2 System Core Matrix

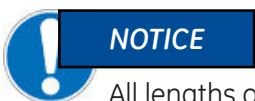

**NOTICE**

All lengths of cable are:

- in useable meter when you look at group level, or
- in meters (connector to connector) when you look at the cable level.

For a description of how to use the following cable group schematics, see below:

Figure 122 Example of cable group schematic

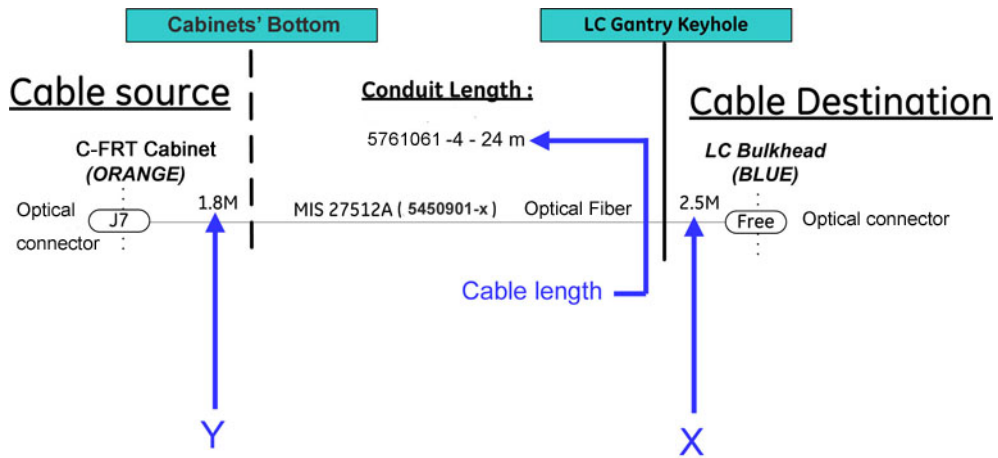

Cable length data is as follows:

- **Cable Length** = the total cable length, connector to connector (example above is 24 meters).
- **X + Y** = used length for connection within system (example above is 4.3 meters).
- **Cable Length - (X + Y)** = available length for conduit run (example above is 19.7 meters).

Figure 123 Cable Group 1 and Ground Cable Group – From Technical Room to Exam Room

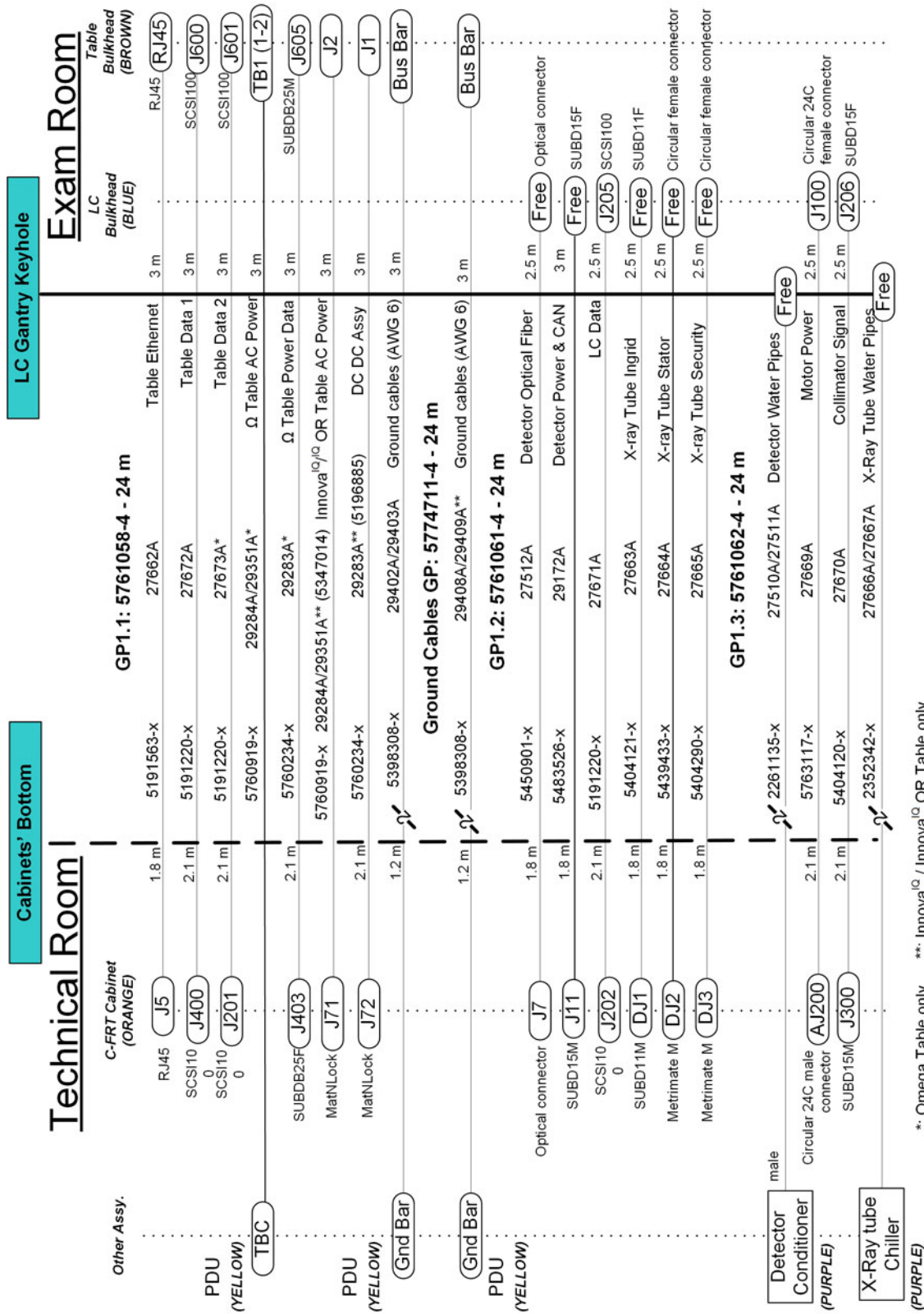

Figure 124 Cable Group 2 – From Technical Room to Control Room

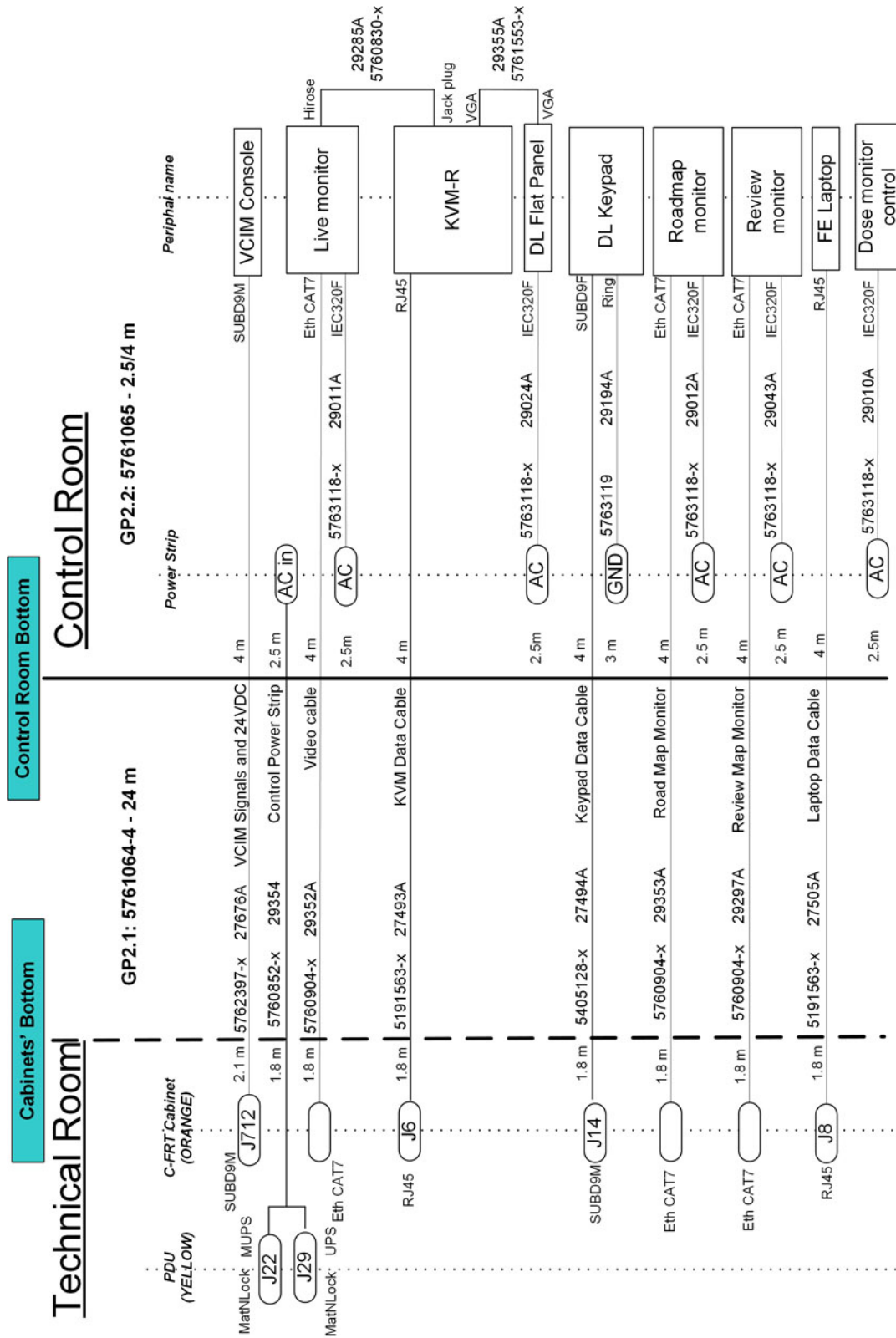

Figure 125 Fast Link Cable Group - Option

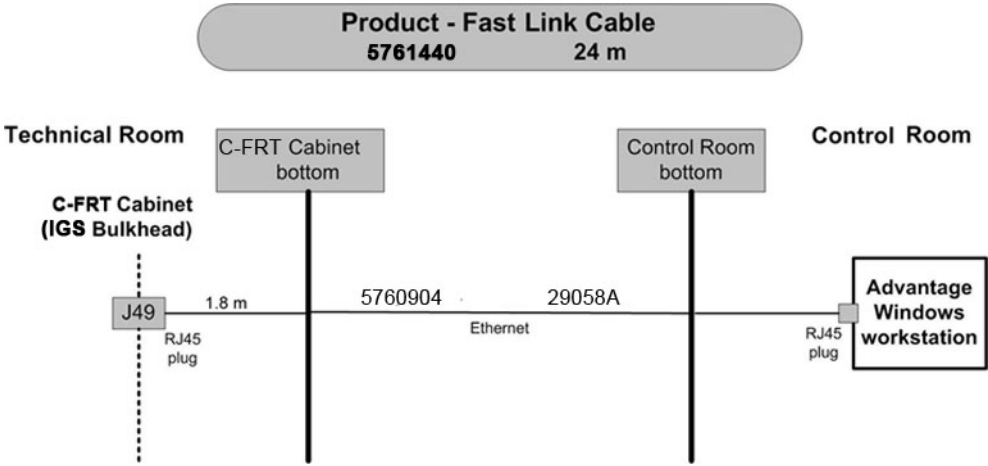
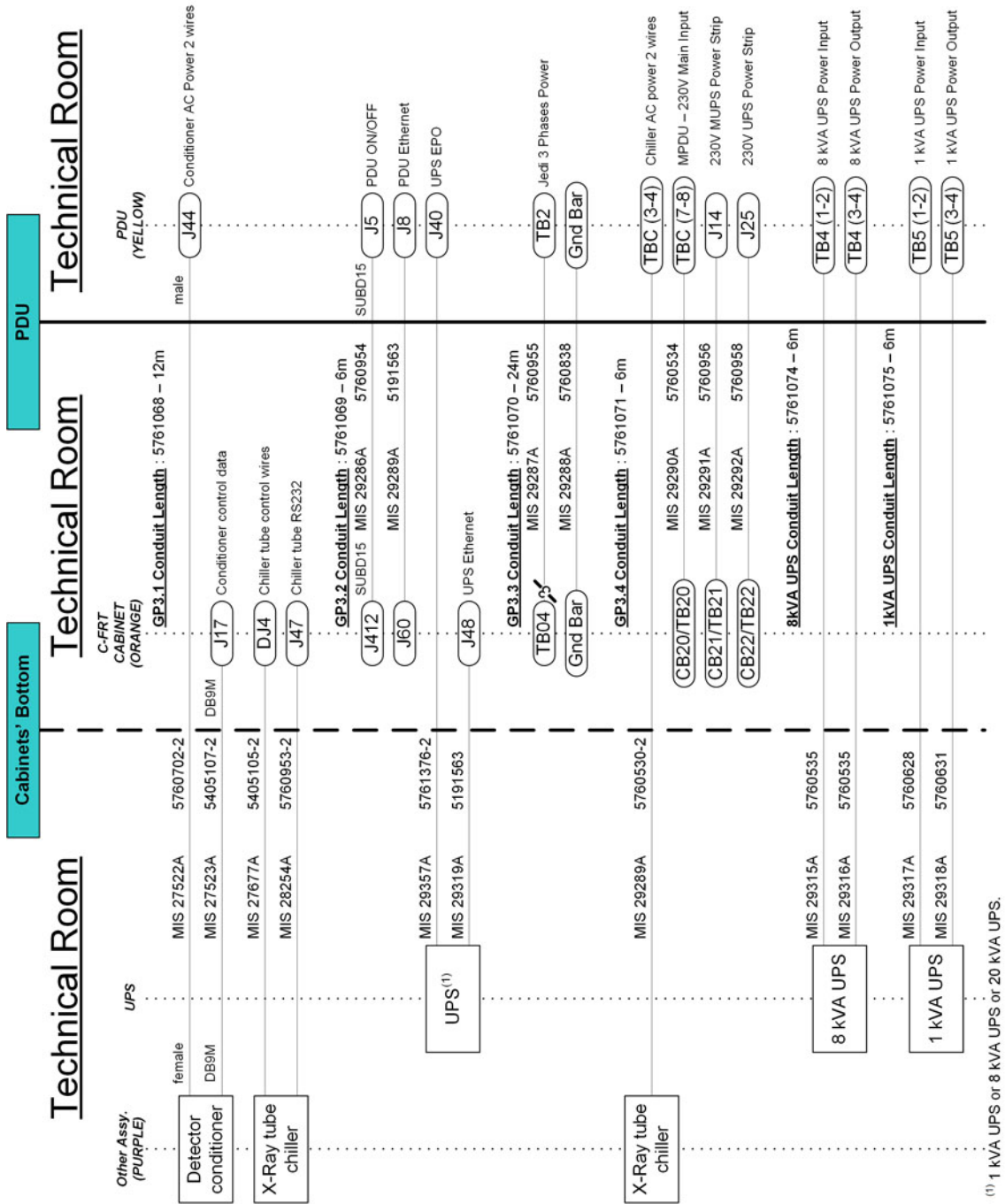

Figure 126 Cable Group 3 – From Technical Room to Technical Room



(1) 1 kVA UPS or 8 kVA UPS or 20 kVA UPS.

Figure 127 Cable Group 4 – From Technical Room to optional Monitors

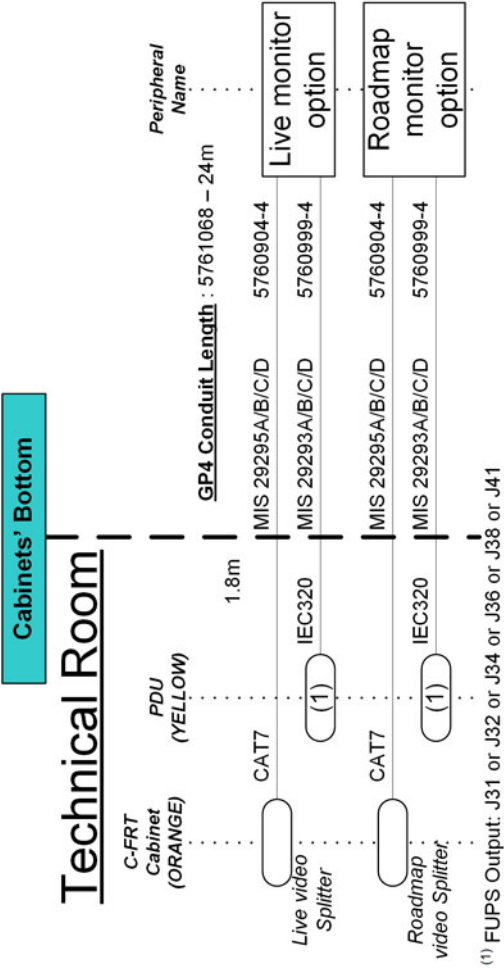

Figure 128 Cable Group – From Technical Room to LCD Monitor Suspension

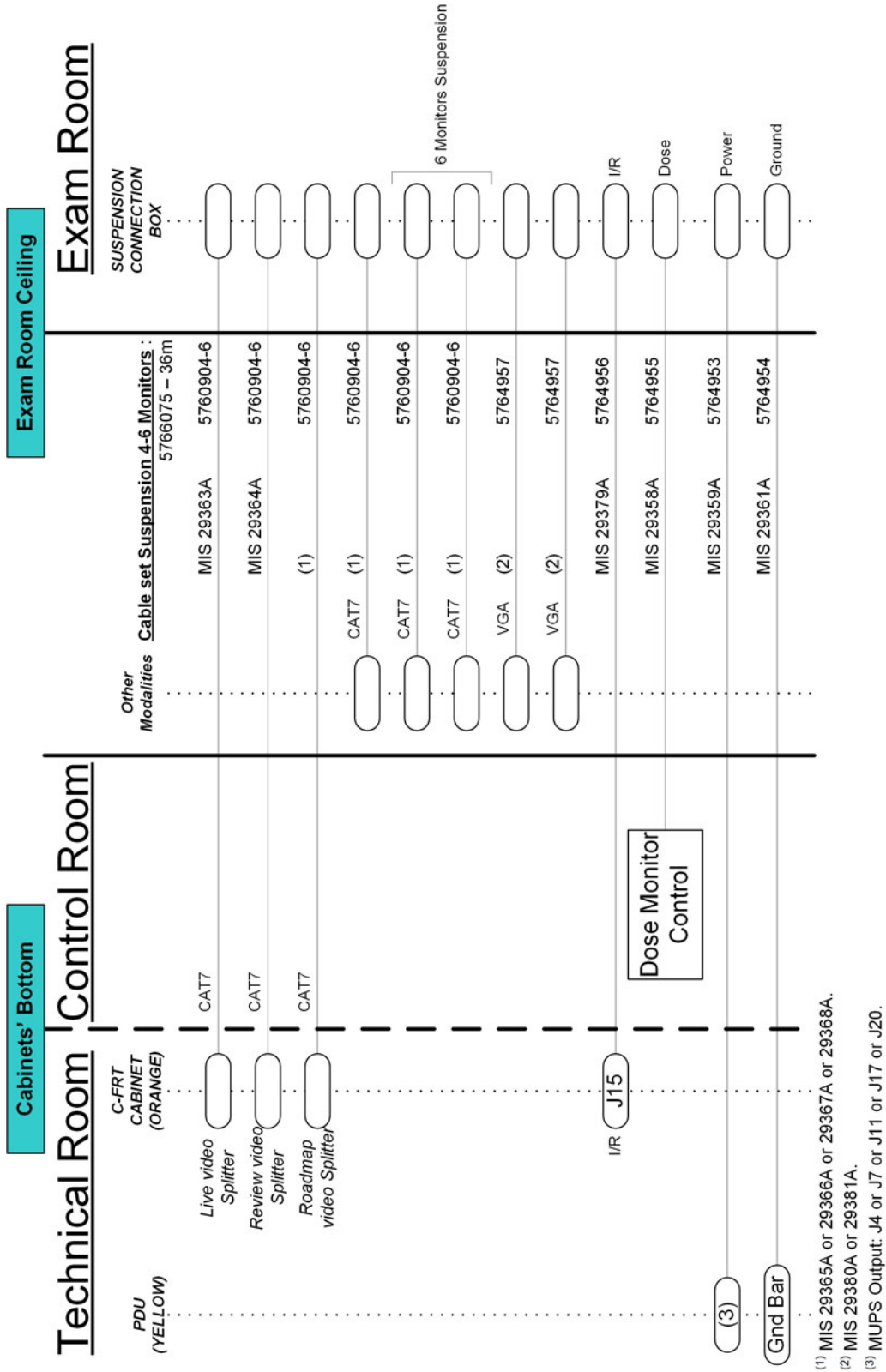

Figure 129 Cable Group - From Technical Room to LDM Mavig Suspension

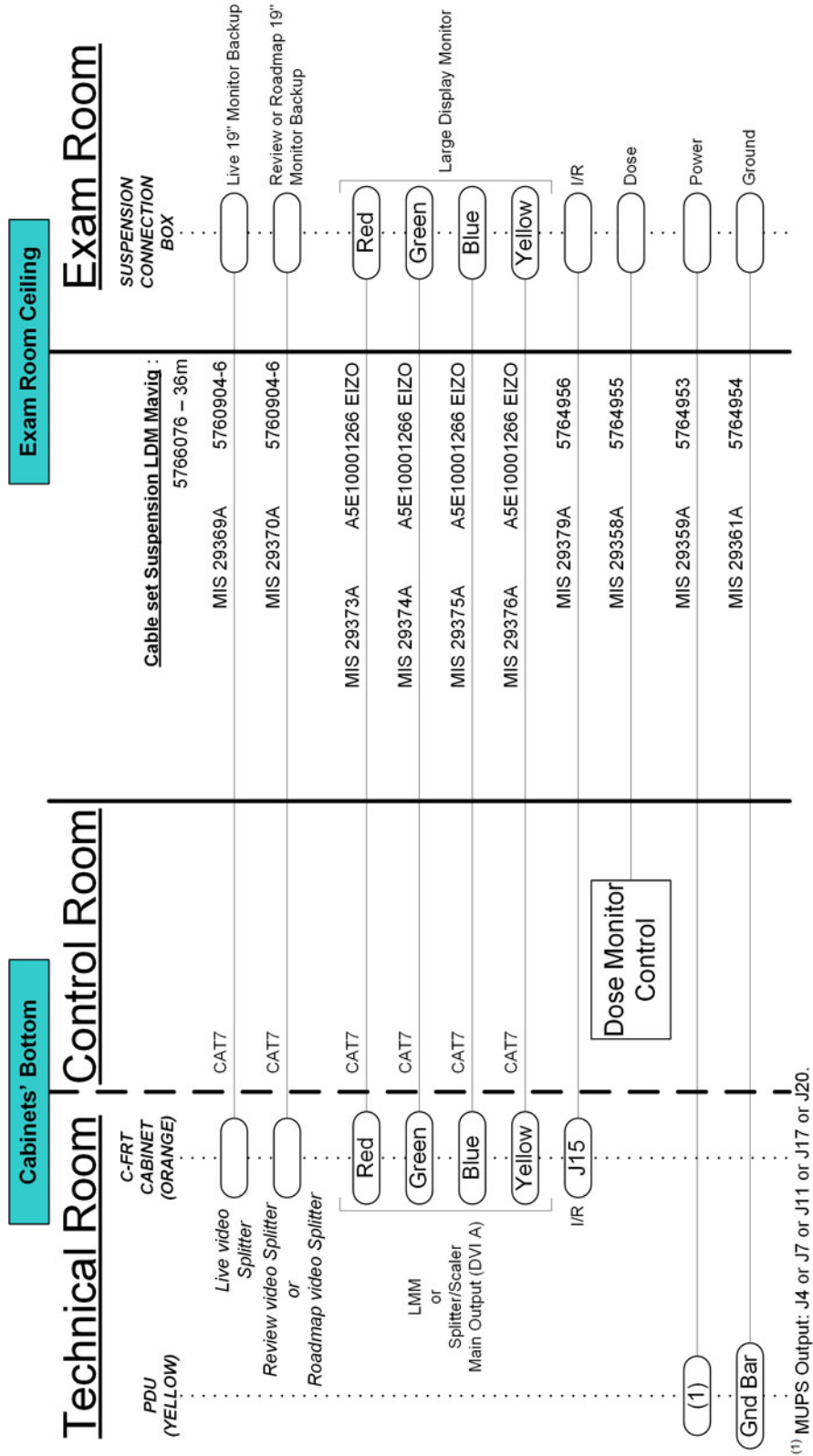

Figure 130 Cable Group – From Technical Room to LDM 3rd Party Suspension

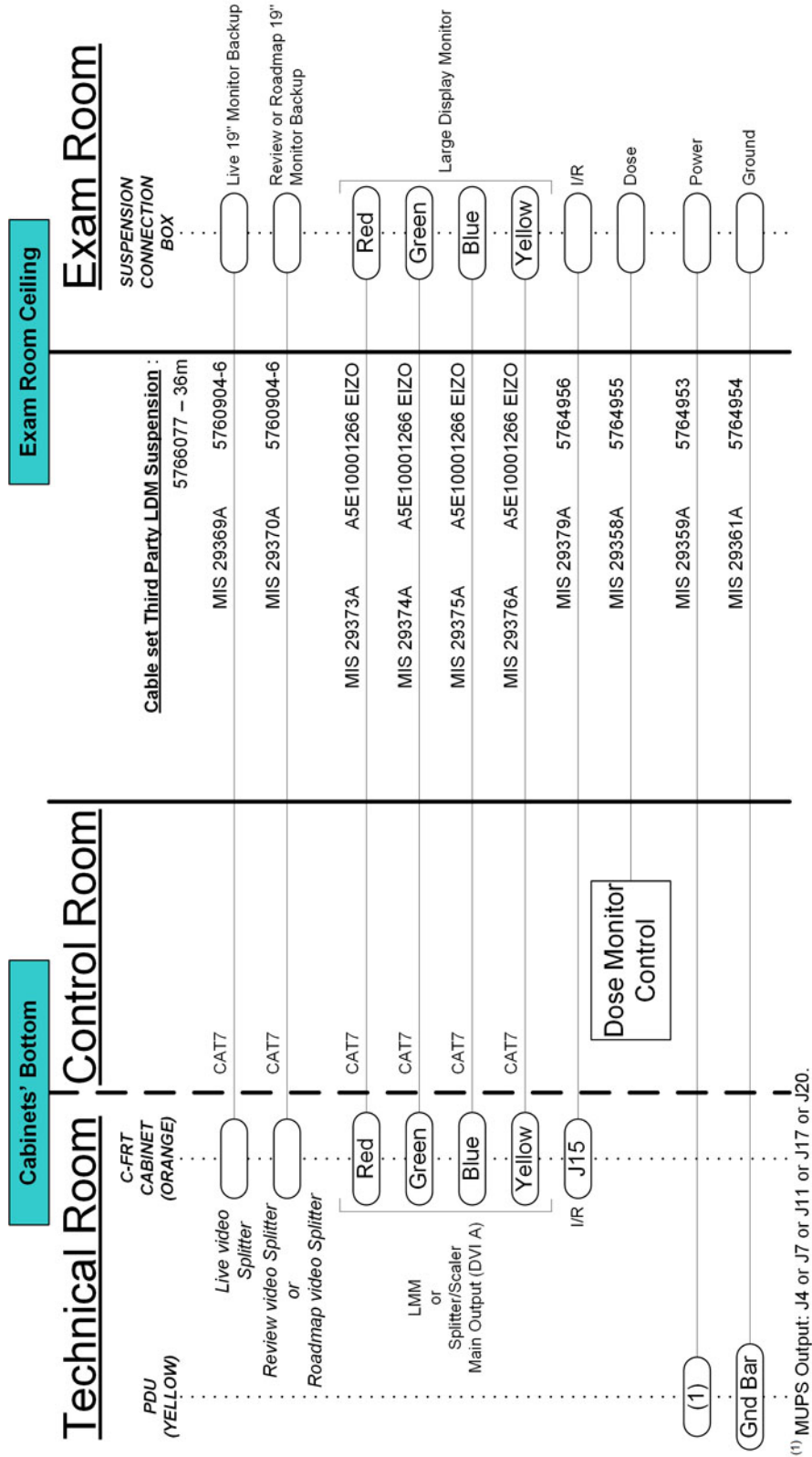
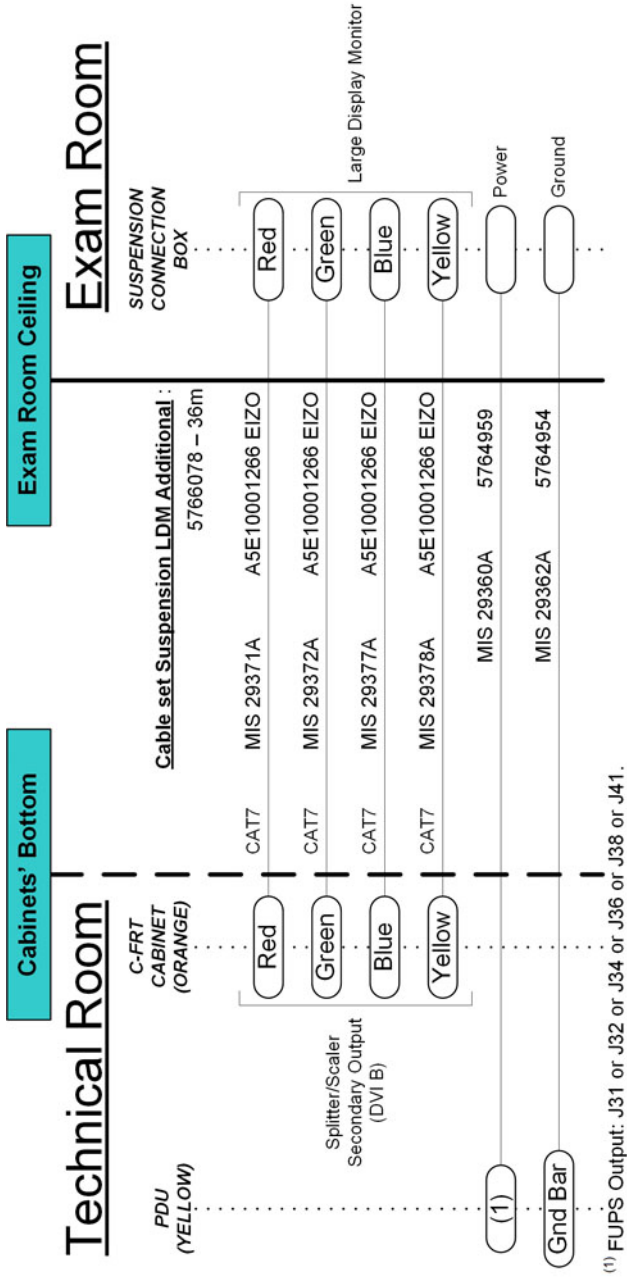

Figure 131 Cable Group – From Technical Room to additional LDM



## 5.5.1.3 Physical Run - System Core Detail

Table 36

MIS number	Cable Assembly	UL Style	Voltage rating (V)	Max Voltage carried (V)	Cable diameter (mm)	Connector type	Bigger Plug size (mm)
<b>Group n°1 (From Technical Room to Exam Room)</b>							
27510A	2261135					WATER HOSE	
27511A	2261135					WATER HOSE	
27512A	5450901					OPTICAL FIBER	
27662A	5191563		30		7	AMP 8 pin RJ45	
27663A	5404121	2789	600		13.8	DB 11 pin	34.4
27664A	5439433						
27665A	5404290	2463	300		9.2	Metrimate 6 pin	29
27666A	2352342					WATER HOSE	
27667A	2352342					WATER HOSE	
27669A	5763117						
27670A	5404120	2789	300			HES 15 pin	
27671A	5404120	2789	30		10.9	Amplimite 100 pin	84.6
27672A	5191220	2789	30		10.9	Amplimite 100 pin	84.6
27673A	5191220	2789	30		10.9	Amplimite 100 pin	84.6
29172A	5483526	2464	300		12.7		
29284A / 29351A	5760919	2587	600				
29283A	5760234						
29402A	5398308						
29403A	5398308						
<b>Ground Cables Group</b>							
29408A	5398308	1019	600		9.1	Pre-stripping, ring terminal (only with Innova <sup>IQ</sup> and Innova <sup>IQ</sup> OR table (P/N 5142213-001)	12

continued							
MIS number	Cable Assembly	UL Style	Voltage rating (V)	Max Voltage carried (V)	Cable diameter (mm)	Connector type	Bigger Plug size (mm)
29409A	5398308	1019	600		9.1	Pre-stripping, ring terminal (only with Innova <sup>IQ</sup> and Innova <sup>IQ</sup> OR table (P/N 5142213-001)	12
<b>Group n°2 (From Technical Room to Control Room)</b>							
27493A	5191563						
27494A	5405128	2464	300		6	DB 9 pin	30.9
27505A	5191563						
27676A	5762397						
29010A	5763118						
29011A	5763118						
29012A	5763118						
29024A	5763118		1				
29043A	5763118						
29194A	5763119						
29285A	5760830						
29297A	5760904						
29352A	5760904						
29353A	5760904						
29354A	5760852					I	
29355A	5761553						
<b>Optional Fast Link Cable</b>							
29058A	5760904						
<b>Group n°3 (From Technical Room to Technical Room)</b>							
27677A	5405105	2463	600		8.3	Metrimate 6 pin	29.8
28254A	5760953						
29356A	5760702						
27523A	5405107						

continued							
MIS number	Cable Assembly	UL Style	Voltage rating (V)	Max Voltage carried (V)	Cable diameter (mm)	Connector type	Bigger Plug size (mm)
29286A	5760954						
29287A	5760955						
29288A	5760838						
29289A	5760530						
29290A	5760534						
29291A	5760956						
29292A	5760958						
29298A	5191563					RJ45	
29319A	5191563					RJ45	
29357A	5761376						
<b>Group n°4 (Optional Monitor)</b>							
29293A /B/C/D	5760999	2343					
29295A /B/C/D	5760904						
<b>1 kVA UPS Cable Group</b>							
29317A	5760628						
29318A	5760631						
<b>8 kVA UPS Cable Group</b>							
29315A	5760535						
29316A	5760535						
<b>Cable Set Suspension 4–6 Monitors</b>							
29358A	5764955						
29359A	5764953						
29361A	5764954						
29363A	5760904						
29364A	5760904						
29365A	5760904						

continued							
MIS number	Cable Assembly	UL Style	Voltage rating (V)	Max Voltage carried (V)	Cable diameter (mm)	Connector type	Bigger Plug size (mm)
29366A	5760904						
29367A	5760904						
29368A	5760904						
29379A	5764956						
29380A	5764957						
29381A	5764957						
<b>Cable Set Suspension LDM Mavig Suspension</b>							
29358A	5764955						
29359A	5764953						
29361A	5764954						
29369A	5760904						
29370A	5760904						
29373A	A5E1000 1266 EI-ZO						
29374A	A5E1000 1266 EI-ZO						
29375A	A5E1000 1266 EI-ZO						
29376A	A5E1000 1266 EI-ZO						
29379A	5764956						
<b>Cable Set Suspension LDM Additional</b>							
29360A	5764859						
29362A	5764954						
29371A	A5E1000 1266 EI-ZO						

continued							
MIS number	Cable Assembly	UL Style	Voltage rating (V)	Max Voltage carried (V)	Cable diameter (mm)	Connector type	Bigger Plug size (mm)
29372A	A5E1000 1266 EI-ZO						
29377A	A5E1000 1266 EI-ZO						
29378A	A5E1000 1266 EI-ZO						
<b>Cable Set Suspension LDM 3rd Party Suspension</b>							
29358A	5764955						
29359A	5764953						
29361A	5764954						
29369A	5760904						
29370A	5760904						
29373A	A5E1000 1266 EI-ZO						
29374A	A5E1000 1266 EI-ZO						
29375A	A5E1000 1266 EI-ZO						
29376A	A5E1000 1266 EI-ZO						
29379A	5764956						

### 5.5.2 MIS (Master Interconnect System)

Innova system interconnect cables are described in MIS (Master Interconnect System) documents. These documents specify all interconnections between components within the system.

Reference: For specific Vascular system interconnect maps and connection details, refer to the following

- *System MIS Map*

- *System MIS Charts*

### **General Guidelines**

Innova System introduces a new system interconnect with a star distribution for all cables from the technical area. The cables are shipped on spools to create cable groups. Cable group 1 for Exam room and cable group 2 for control room. The cable group shall be put in place during the same action. The cables are routed in the same duct.

The HV cables could be pulled separately.

## **5.5.3 Cable Channeling**

### **5.5.3.1 General**

High voltage and power cables must be separated from other cables. Use a separate trough in the duct system, or use a separate conduit. Minimize cable length between the MDP and the PDU to reduce voltage regulation problems and wiring costs.

For information about the cables supplied with your system, please refer to [5.5.1 Physical Runs on page 156](#).

### **5.5.3.2 Conduit**

Separate conduits must be used for power and signal wires. These wires must be kept separated from each other.

Using conduit imposes some important considerations when used with this system. Of primary concern, the majority of cables used are pre-terminated. Pre-termination greatly simplifies interconnection but makes cable-pulling difficult because of the added dimensions of the connectors.

Conduit must be large enough to pass the cable and connector through with all other cables already in the conduit. Also, the size of conduit chosen must allow for future growth. There is the possibility of additional cables being added later as the system is developed and options are added.

The use of conduit is recommended for cables running overhead between rooms, especially when a diagonal run provides the shortest cable path

### **5.5.3.3 Electrical Ducts**

It's important that electrical ducts have separate compartments for power and signal wires. These wires must be kept separated from each other for proper system operation.

Electrical ducts have advantages, when used with a single room or two adjacent rooms. Electrical ducts combine cabling in a neat and functional appearance, with accessibility and room for expansion.

#### **NOTE**

Medrad AVANTA and Mac-lab cables exit behind the table in the Exam Room.

#### **NOTE**

For **Fast Link** cable (C-FRT Cabinet - AW station), the static operation bending radius must be at least 4 times the outer cable diameter.

It is the responsibility of the site planner to provide the appropriate solution to the table exit (e.g gas box, Clab II, Tram module, connection interface box).

**NOTE**

Specific Recommendations for installation with GE ECG Device such as Maclab, CardioLab or ComboLab:

- TRAM RAC in Exam Room with cable 2016134-106 routed back to Control Room where the other modules & PC are installed
- If no GE Maclab cable 2016134-106 installed between the TRAM (Exam Room) and the Control Room, need to route it so that installation/connection of Physio module can be made in Control Room.

**NOTE**

**MEDRAD Avanta Table mount with floor Medrad bracket (this configuration is not authorized with an Innova<sup>IQ</sup> and Innova<sup>IQ</sup> OR Table):** A 76.2 mm (3 in) and max 25 m (984 in) length conduit between Technical Room and Exam Room shall be prepared below the floor for the three injector cables. It is recommended to use the MEDRAD Avanta floor mounting bracket to cover the duct hole in the Exam Room if there is no gases box.

**Figure 132 MEDRAD Avanta mounting bracket**

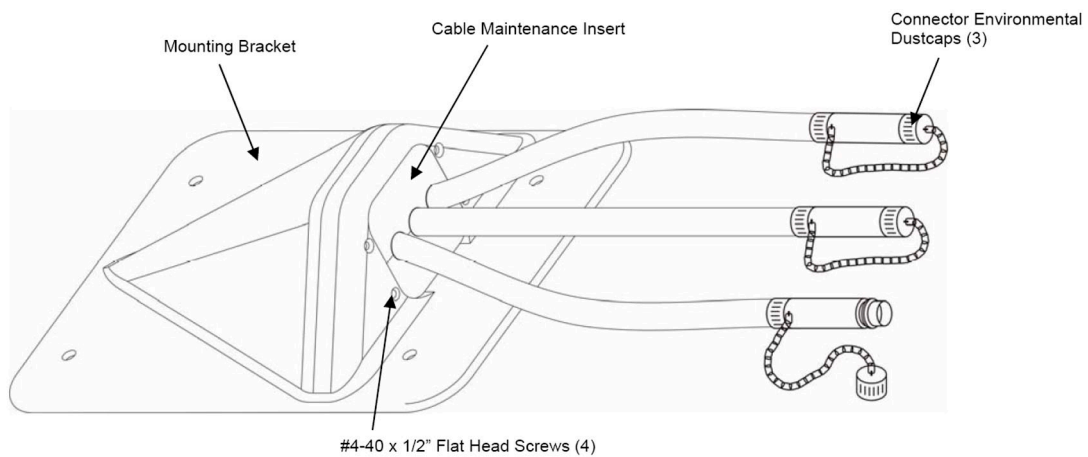

Floor mount installation can be accomplished one of two ways:

- Connectors mounted in trough under mounting bracket (Figure 1)
- Connectors mounted above mounting bracket (Figure 2)

**Figure 133 MEDRAD Avanta floor mounting methods**

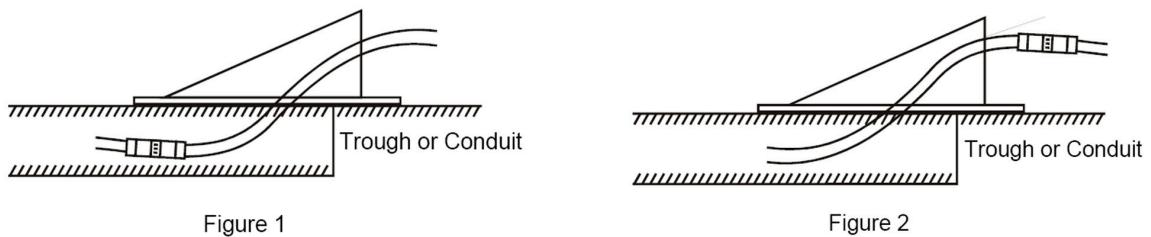

For further MEDRAD Avanta floor mounting, see the Installation guide MEDRAD Avanta Floor Mounting Bracket.

Figure 134 Cable Channeling Layout

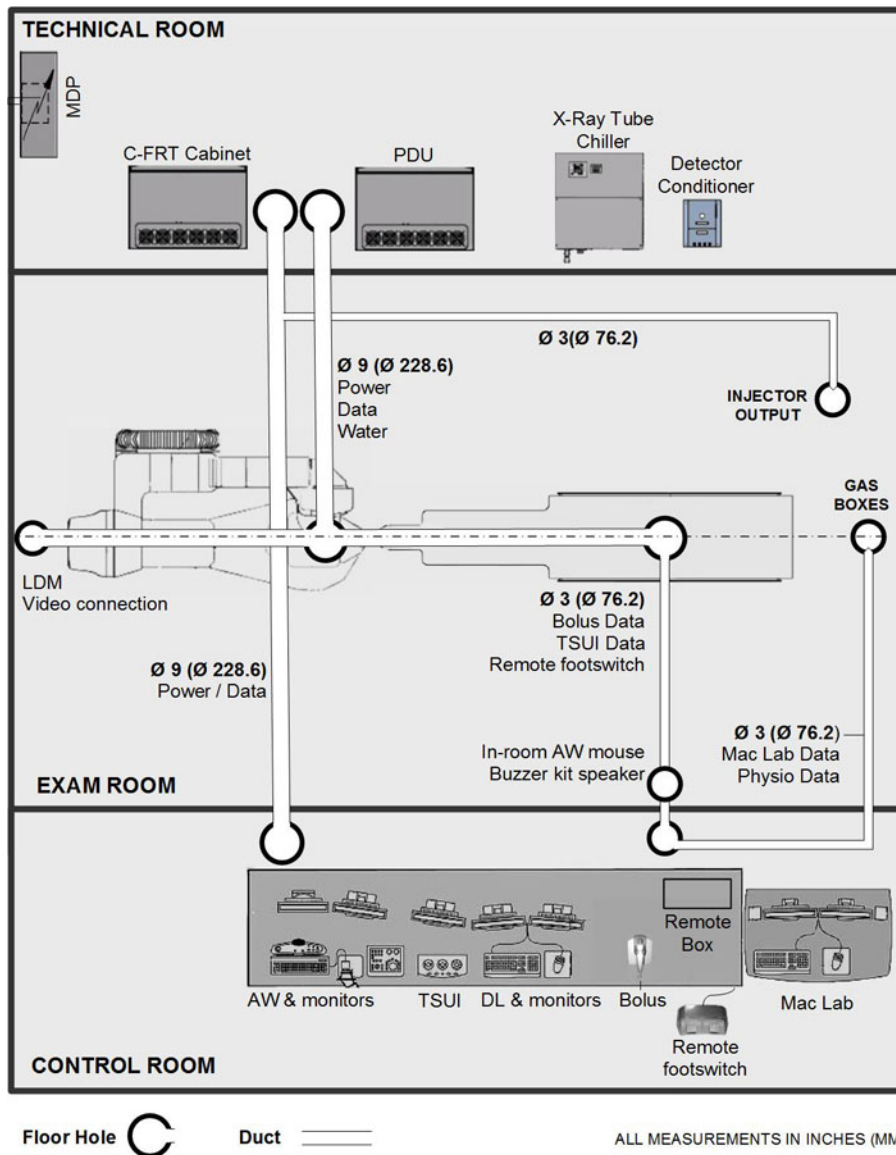

**NOTICE**

In some countries, it is forbidden to run electrical cables and water pipes in the same conduit. In this case, two separate conduits are required.



**NOTICE**

Raceways or cable trays containing electrical conductors shall not contain any pipe, tube or equal for steam, water, air, gas, drainage or any service other than electrical.

**NOTE**

The length of the cable between the Table and the Remote Box is 18 m. The length of the cables between the Remote Box and the Control Room TSUI is 4 m.

**NOTE**

Only the MEDRAD Mark 7 injector with extension cable and the MEDRAD Avanta injector with extension cable require a separate duct.

**NOTE**

The Physio cable can run in the same conduit as the Bolus cable. In this case, it is required to have a conduit between the table and the physio gases box.

If no conduit available between rear of table and Control Room (no Remote TSUI, no MacLab...), need to define proper cable routing or create new conduit as per PIM requirements.

If there is no physio gases box behind the table in the lay out, find a local solution to hide the hole in the floor and the cable exit.

# Chapter 6 Communication Requirements

## 6.1 Network Requirements

### 6.1.1 General Information

The system is provided with a firewall unit, that allows connection to the hospital network for pushing the DICOM images or for service remote access (InSite). This firewall is compatible with 10/100/1000 (Gigabit Ethernet) networks.

The C-FRT Cabinet provides an Ethernet RJ45 plug, the hospital is responsible for providing the Ethernet cable between the system and the hospital network.

For complete descriptions of these connectivity solutions, please refer to the Broadband Solutions catalogue available through your local GEHC sales and service representative.

Connectivity Process and pre-installations checklists are available in the Broadband Connectivity PIM available through your local GEHC sales and service representative.

### 6.1.2 InSite Connection

InSite requires a VPN connection to the system. To create this connection, the system IP and site IT contact information, should be given to your local GEHC sale and service representative before the system installation begins. Once submitted, a member of the GEHC Broadband Solutions team will contact the site IT to set up the VPN connection.

The SupportCentral links where information from the InSite Connectivity Team or Insite Request Form can be found are:

- **Americas:** [http://supportcentral.ge.com/products/sup\\_products.asp?prod\\_id=73661](http://supportcentral.ge.com/products/sup_products.asp?prod_id=73661)
- **Asia:** [http://supportcentral.ge.com/products/sup\\_products.asp?prod\\_id=19181](http://supportcentral.ge.com/products/sup_products.asp?prod_id=19181)
- **Europe:** [http://supportcentral.ge.com/products/sup\\_products.asp?prod\\_id=24026](http://supportcentral.ge.com/products/sup_products.asp?prod_id=24026)

### 6.1.3 IP Addresses

IP addresses for DL and AW PCs have to be requested to the Hospital IT at the time of pre-install to not delay the installation.

New requirements related to the Privacy and Security configurations also apply with the new system software generation. Refer to [6.2 Privacy and Security Configuration on page 177](#).

## 6.2 Privacy and Security Configuration

The new Privacy and Security features available with the System require to be configured according to the security policy requested by the hospital.

To ensure the installation is successful and is not delayed because of missing information, it is required to gather all needed information as part of the pre-install process.

The typical parameters are the one listed below. The complete list is provided in Tab "Security Configuration" of the document *IGS System Installation Prerequisites - DOC2024755*. See also Important Notice below.

- **Machine Account**
- **User Authentication**
- **Authorization**
- **Audit Trail**
- **Malware protection**
- **Network Security**
- **Data Transmission**
- **Other Requirements**



**NOTICE**

- Always refer to the detailed Checklist provided in the document *IGS System Installation Prerequisites - DOC2024755* available from MyWorkshop. Always use the last revision which will contain all mandatory updates.
- For details on the new Privacy and Security features available with this machine, refer to the document *Privacy and Security Guide - DOC1972949* available from MyWorkshop.
- Support on Privacy and Security can also be found here (USCAN only): [http://supportcentral.ge.com/products/sup\\_products.asp?prod\\_id=259836](http://supportcentral.ge.com/products/sup_products.asp?prod_id=259836).



Innova™ IGS 5