



GE Healthcare

Technical Publications

Direction No 2118780

Release 3.12 and 4.2

CentricityTM RISi DICOM Conformance Statement

© - General Electric Company - All rights reserved.

Table of Contents

1	<i>Introduction</i>	4
1.1	Overview	4
1.2	OVERALL DICOM CONFORMANCE STATEMENT DOCUMENT STRUCTURE	4
1.3	INTENDED AUDIENCE	6
1.4	SCOPE AND FIELD OF APPLICATION	7
1.5	IMPORTANT REMARKS	7
1.6	REFERENCES	8
1.7	DEFINITIONS	8
1.8	SYMBOLS AND ABBREVIATIONS	9
2	<i>Summary</i>	10
3	<i>MedoraCOM Server</i>	12
3.1	Implementation Model	12
3.1.1	Application Data Flow Diagram	12
3.1.2	Functional Definition of AE	13
3.1.3	Sequencing of Real-World Activities	13
3.2	Application Entity Specification	14
3.2.1	Association Establishment Policies	14
3.2.2	Association Acceptance Policy	15
4	<i>MedoraCOM Image Query/Retrieve services</i>	23
4.1	Implementation Model	23
4.1.1	Application Data Flow Diagram	23
4.1.2	Functional Definition of AE	24
4.1.3	Sequencing of Real-World Activities	24
4.2	Application Entity Specification	24
4.2.1	Association Establishment Policies	24
4.2.2	Association Initiation Policy	25
5	<i>MedoraCOM PPS MANAGER</i>	28
5.1	Implementation Model	28
5.1.1	Application Data Flow Diagram	28
5.1.2	Functional Definition of AE	29
5.1.3	Sequencing of Real-World Activities	29
5.2	Application Entity Specification	29
5.2.1	Association Establishment Policies	30
5.2.2	Association Acceptance Policy	30
5.2.3	Association Initiation Policy	40
6	<i>Communication Profiles</i>	42

6.1	Supported Communication Stacks	42
6.1.1	TCP/IP Stack	42
6.1.2	Physical Media Support	42
7	Configuration	43
8	Support of Extended Character Sets	44
9	Codes and Controlled Terminology	45
10	Security profiles	46

1 INTRODUCTION

1.1 OVERVIEW

This DICOM Conformance Statement is divided into sections as described below:

Section 1 (Introduction) describes the overall structure, intent, and references for this Conformance Statement

Section 2 (Summary) gives a summary of all DICOM services that Centricity RISi supports and the references to the Chapters where the conformance statement of these services are present.

Section 3 (MedoraCOM Server) specifies the Centricity RISi compliance to DICOM requirements for Basic Modality Worklist SOP Class and Basic Study Content Notification SOP Class.

Section 4 (MedoraCOM Image Query / Retrieve) specifies the Centricity RISi compliance to DICOM requirements for Image Query / Retrieve SOP Classes.

Section 5 (MedoraCOM PPS Manager) specifies the Centricity RISi compliance to DICOM requirements for Modality Performed Procedure Step SOP Classes.

Section 6 - 8 give the general information applied to all of the services described in sections 3 - 5, like network interface, configuration, character set support, etc.

1.2 OVERALL DICOM CONFORMANCE STATEMENT DOCUMENT STRUCTURE

The Documentation Structure of the GE Conformance Statements and their relationship with the DICOM Conformance Statements is shown in the illustration below.

Illustration 1-1

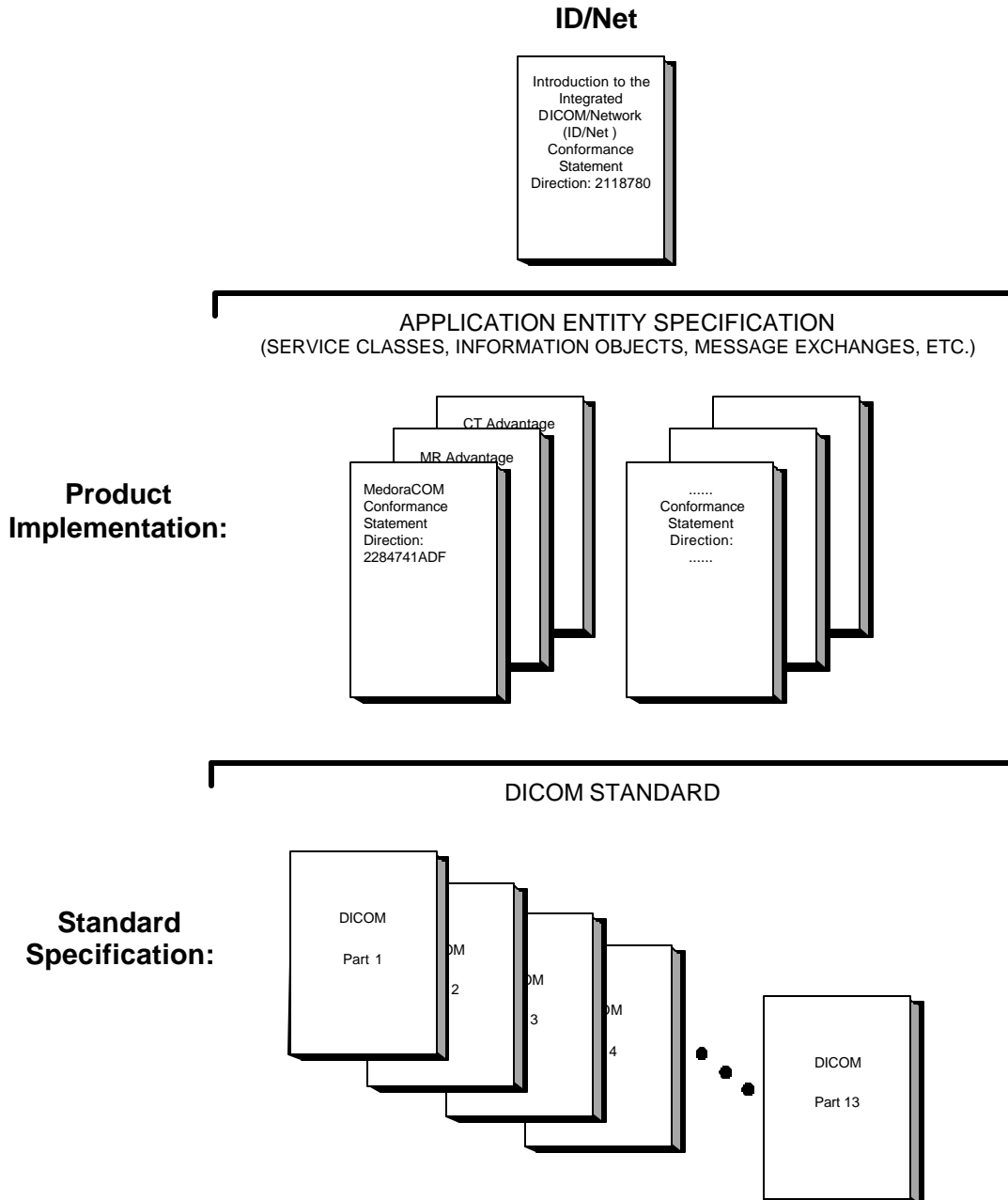

This document specifies the DICOM implementation. It is entitled:

MedoraCOM - RIS-PACS Communication Manager 4.2
Conformance Statement for DICOM
Direction: 2118780.

This DICOM Conformance Statement documents the DICOM Conformance Statement and Technical Specification which are required to interoperate with the GE network interface. Introductory information, which is applicable to all GE Conformance Statements, is described in the document:

Introduction to the Integrated DICOM/Network (ID/Net)
Conformance Statement
Direction: 2118780.

This Introduction familiarises the reader with DICOM terminology and general concepts. It should be read prior to reading the individual products' GE Conformance Statements. The GE Conformance Statement, contained in this document, also specifies the Lower Layer communications, which it supports (e.g., TCP/IP). However, the Technical Specifications are defined in the DICOM Part 8 standard.

For more information including Network Architecture and basic DICOM concepts, please refer to the Introduction.

For the convenience of software developers, there is "collector" Direction available. By ordering the collector, the Introduction described above and all of the currently published GE Product Conformance Statements will be received. The collector Direction is:

ID/Net Conformance Statements
Direction: 2117016

For more information regarding DICOM, copies of the Standard may be obtained on the Internet at <http://medical.nema.org>. Comments on the standard may be addressed to:

DICOM Secretariat
NEMA
1300 North 17th Street
Suite 1847
Rosslyn, VA 22209
USA
Phone: (703) 841-3200

1.3 INTENDED AUDIENCE

The reader of this document is concerned with software design and/or system integration issues. It is assumed that the reader of this document is familiar with the DICOM Standards and with the terminology and concepts, which are used in those Standards.

If readers are unfamiliar with DICOM terminology they should first refer to the document listed below, then read the DICOM Standard itself, prior to reading this DICOM Conformance Statement document.

Introduction to the Integrated DICOM/Network (ID/Net)
Conformance Statement
Direction: 2118780

1.4 SCOPE AND FIELD OF APPLICATION

It is the intent of this document, in conjunction with the *Introduction to the Integrated DICOM/Network (ID/Net) Conformance Statement, Direction: 2118780*, to provide an unambiguous specification for GE implementations. This specification, called a Conformance Statement, includes a DICOM Conformance Statement and is necessary to ensure proper processing and interpretation of GE medical data exchanged using DICOM. The GE Conformance Statements are available to the public.

The reader of this DICOM Conformance Statement should be aware that different GE devices are capable of using different Information Object Definitions. For example, a GE CT Scanner may send images using the CT Information Object, MR Information Object, Secondary Capture Object, etc. Included in this DICOM Conformance Statement are the Module Definitions, which define all data elements used by this GE implementation. If the user encounters unspecified private data elements while parsing a GE Data Set, the user is well advised to ignore those data elements (per the DICOM standard). Unspecified private data element information is subject to change without notice. If, however, the device is acting as a "full fidelity storage device", it should retain and re-transmit all of the private data elements, which are sent by GE devices.

1.5 IMPORTANT REMARKS

The use of these DICOM Conformance Statements, in conjunction with the DICOM Standards, is intended to facilitate communication with GE imaging equipment. However, **by itself, it is not sufficient to ensure that inter-operation will be successful**. The **user (or user's agent)** needs to proceed with caution and address at least four issues:

- **Integration** - The integration of any device into an overall system of interconnected devices goes beyond the scope of standards (DICOM), and of this introduction and associated DICOM Conformance Statements when interoperability with non-GE equipment is desired. The responsibility to analyse the applications requirements and to design a solution that integrates GE imaging equipment with non-GE systems is the **user's** responsibility and should not be underestimated. The **user** is strongly advised to ensure that such an integration analysis is correctly performed.
- **Validation** - Testing the complete range of possible interactions between any GE device and non-GE devices, before the connection is declared operational, should not be overlooked. Therefore, the **user** should ensure that any non-GE provider accepts full responsibility for all validation required for their connection with GE devices. This includes the accuracy of the image data once it has crossed the interface between the GE imaging equipment and the non-GE device and the stability of the image data for the intended applications. Such a validation is required before any clinical use (diagnosis and/or treatment) is performed. It applies when images acquired on GE imaging equipment are processed/displayed on a non-GE device, as well as when images acquired on non-GE equipment is processed/displayed on a GE console or workstation.

- **Future Evolution** - GE understands that the DICOM Standard will evolve to meet the user's growing requirements. GE is actively involved in the development of the DICOM Standard. DICOM will incorporate new features and technologies and GE may follow the evolution of the Standard. The GE protocol is based on DICOM as specified in each DICOM Conformance Statement. Evolution of the Standard may require changes to devices, which have implemented DICOM. **In addition, GE reserves the right to discontinue or make changes to the support of communications features (on its products) reflected on by these DICOM Conformance Statements.** The user should ensure that any non-GE provider, which connects with GE devices, also plans for the future evolution of the DICOM Standard. Failure to do so will likely result in the loss of function and/or connectivity as the DICOM Standard changes and GE Products are enhanced to support these changes.
- **To be informed of the evolution of the implementation described in this document, the User is advised to regularly check the GE Internet Server <http://www.ge.com/dicom>.**
- **Interaction** - It is the sole responsibility of the non-GE provider to ensure that communication with the interfaced equipment does not cause degradation of GE imaging equipment performance and/or function.

1.6 REFERENCES

A list of references, which is applicable to all GE Conformance Statements, is included in the *Introduction to the Integrated DICOM/Network (ID/Net) Conformance Statement, Direction: 2118780*.

The information object implementation refers to DICOM PS 3.3 (Information Object Definition).

1.7 DEFINITIONS

A set of definitions which is applicable to all GE Conformance Statements is included in the *Introduction to the Integrated DICOM/Network (ID/Net) Conformance Statement, Direction: 2118780*.

1.8 SYMBOLS AND ABBREVIATIONS

A list of symbols and abbreviations which is applicable to all GE Conformance Statements is included in the *Introduction to the Integrated DICOM/Network (ID/Net) Conformance Statement, Direction: 2118780*.

Nevertheless there are the following abbreviations used in this document:

- MCSRV **MedoraCOM SeRVer**
- MCWLP **MedoraCOM WorkList Provider**
- MCSCNP **MedoraCOM Study Content Notification Provider**
- MCQRS **MedoraCOM Query/Retrieve Services**
- MCPPS **MedoraCOM PPS Manager**

2 SUMMARY

This document is the DICOM Conformance Statement for MedoraCOM. MedoraCOM is the DICOM conformant connectivity package for Centricity RISi. **As MedoraCOM is available on different operating system platforms there are however some differences in implementation and not all of these operating system dependant editions support all of the DICOM Service Classes listed below. Even if all editions provide the service class there may be some differences in implementation. The main deviations are between MedoraCOM running on Windows[®] and MedoraCOM running on Unix derivatives. If there are differences in implementation there will be some remarks in the chapters describing the DICOM service classes.** In summary MedoraCOM supports the following DICOM functions for the demographic data exchange, work flow management and image communication:

- Service Class Provider (SCP) of the DICOM Verification Service Class
- Service Class User (SCU) of the DICOM Verification Service Class
- Service Class Provider (SCP) of the DICOM Basic Modality Worklist Service Class
- Service Class Provider (SCP) of the DICOM Basic Study Content Notification Service Class
- Service Class User (SCU) of the DICOM Query / Retrieve Service Class
- Service Class User (SCU) of the DICOM Modality Performed Procedure Step Service Class
- Service Class Provider (SCP) of the DICOM Modality Performed Procedure Step Service Class

These DICOM services have been implemented in a number of applications, which can be configured, to share the same DICOM Application Entity Title or use their own DICOM Application Entity Titles. In MedoraCOM, all DICOM applications are configured to support the same DICOM Application Entity. In this text, we use the term *MedoraCOM Application Entity* to refer to this global Application Entity. All MedoraCOM DICOM applications share the same *MedoraCOM DICOM Application Entity Title*.

This text presents the DICOM Conformance Statement information of these applications in several chapters organised logically according to their functionality. In the following, a brief road map to these chapters is given to facilitate the reading of this document:

MedoraCOM Server

This chapter includes the SCP of the following service classes:

- **Basic Modality Worklist**
This chapter includes the SCP of the DICOM Basic Modality Worklist Service Class for modality worklist sending after having received a request from a remote DICOM application entity.
- **Basic Study Content Notification**
This chapter includes the SCP of the DICOM Basic Study Content Notification Service Class for study content notification receiving from a remote DICOM node.

- **Image Query & Retrieve**

This chapter includes the SCU of the DICOM Query & Retrieve Service Class for either Centricity RISi users or internal server processes to query/retrieve image information/images from a remote DICOM Query & Retrieve Service Class Provider.

- **Modality Performed Procedure Step (MPPS)**

This chapter includes the SCP and the SCU of the DICOM Modality Performed Procedure Step Service Class. The Modality Performed Procedure Step MPPS Service Class is only supported by the Windows® edition of MedoraCOM. This component has been implemented to provide reception of information related to a performed procedure step from medical modalities or other systems that are acting as an SCU of the Modality Performed Procedure Step Service Class. Furthermore the MedoraCOM PPS manager is able to forward the received information to a third system in order to fulfil the requirements to a PPS manager in terms of IHE.

3 MEDORACOM SERVER

This chapter gives the technical specification of the MedoraCOM Server (MCSRVS) - a part of the DICOM communication interface of GE's Radiology Information System Centricity RISi.

As MCSRVS is not a stand-alone process on the respective system environment, it is part of the so-called "MedoraCOM Server" process.

MCSRVS provides access to a worklist database maintained in Centricity RISi using DICOM protocols and messages. More specifically, it implements the Modality Worklist Management SOP Class as an SCP. As a second functionality MCSRVS provides access to a RIS database maintained in Centricity RISi using DICOM protocols and messages. More specifically, it also implements the Study Content Notification SOP Class as an SCP.

MCSRVS supports a single application entity (AE).

3.1 IMPLEMENTATION MODEL

MedoraCOM is implemented as a collection of one or several components and each of these components provide the support of one or several DICOM Service Classes - SOPs. With this component architecture, MedoraCOM can be configured as really demanded in a concrete installation site. The components can be configured as separate DICOM Application Entities, or they can share one same AE Title. In the first case, MedoraCOM supports multiple AE Titles and in the later case MedoraCOM supports one AE Title.

Usually, all components of MedoraCOM share one same AE Title and MedoraCOM appears as one DICOM application. The installation manual of MedoraCOM provides the configuration information of a concrete installation.

The component MCSRVS has been implemented to act as a Service Class Provider (SCP) of the DICOM Standard Basic Worklist Management Service Class and the Basic Study Content Notification SOP Class. In a client-server-environment, a DICOM SCP acts as a server. In the MedoraCOM documents, therefore, MCSRVS may be also called MedoraCOM Server. The application is either a UNIX® application and can run on most UNIX® platforms or a Windows® process to run on a Windows® system.

The MedoraCOM Server supports one AE Title. The AE Title can be the same AE Title that other components of MedoraCOM support, or another specialised AE Title.

3.1.1 Application Data Flow Diagram

MedoraCOM Server is either a WIN 32 process controlled by the RIS-PACS Communication Manager service able to run on a Microsoft Windows® machine or on a Unix machine.

MedoraCOM Server may be automatically started when the machine is booted or it may be started when the Centricity RISi server processes are launched what means that no user login is required.

A remote DICOM Application Entity initiates an association for DICOM Modality Worklist Service Class to MedoraCOM. When MCSRVS accepts the association, the remote AE transmits the DICOM information objects within the worklist request to MCSRVS. Using these attributes MCSRVS queries the Centricity RISi database for worklist according to the matching keys given in the worklist request. Af-

terwards MCWLP transmits the worklist item(s) within the worklist response back to the remote DICOM node.

A remote DICOM Application Entity initiates an association for DICOM Study Content Notification to MedoraCOM. When MCSRVS accepts the association, the remote AE transmits the study information to MCSRVS. If an SOP instance is successfully received on the association, MCSRVS saves the study information in the Centricity RISi database and tries to build a link between the received data and the corresponding study object in the RIS.

Illustration 3-1

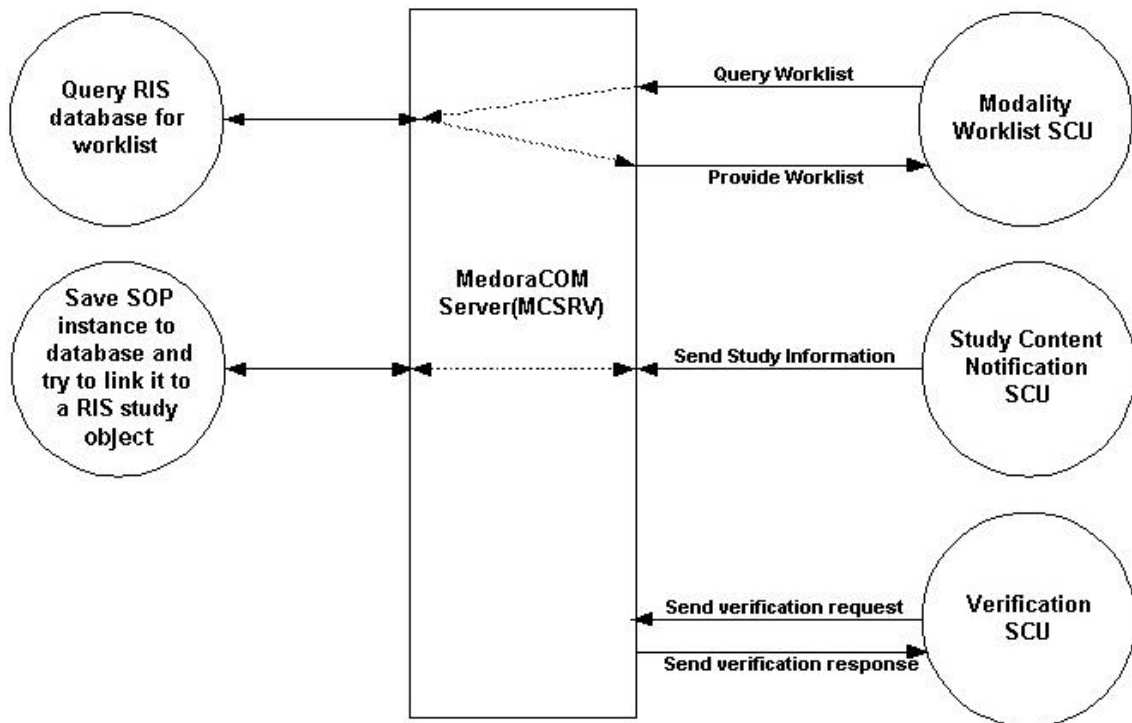

3.1.2 Functional Definition of AE

After being started, MCSRVS is always waiting for an association request from a remote DICOM application entity. MCSRVS will accept an association with the supported SOP classes only for those remote DICOM applications, which are specified in the configuration of MedoraCOM. This means that not all remote DICOM application entities are permitted for example to query a modality worklist from MedoraCOM.

3.1.3 Sequencing of Real-World Activities

3.1.3.1 Basic Modality Worklist

With the Centricity RISi application a radiological examination can be scheduled either by user interaction or by receiving the data by the HIS interface. Based on these actions a study object is created in

the RIS and stored in the RIS database. Based on the configuration of the basic data “workplace” and “medical device” and the dependence between these data also a worklist item is created in the RIS database. In the configuration of the medical device also the DICOM application entity title of the remote modality worklist SCU has to be specified.

Note: Centricity RISi and MedoraCOM support multiple scheduled AE titles per study object. Therefore a single RIS study object can be available as a worklist item in the responses of different modality worklist SCUs. This option may be very useful for scenarios in which the user is not able to decide on what imaging equipment the examination shall take place at the time the study is scheduled.

From the time on the patient is admitted the study will appear in every worklist message, which is transmitted if the given matching keys of a worklist request match the study parameters. After the status of the RIS study object has changed to completed, the study will be no longer included as an item in the worklist message.

3.1.3.2 Basic Study Content Notification

If MCSRVS receives a valid Study Content Notification SOP instance, the related tables of the database will be updated to keep the track of the images archived in the client’s data. Using the information in the database tables, Centricity RISi users can retrieve these images at any later time.

3.2 APPLICATION ENTITY SPECIFICATION

MCSRVS is one functional component of MedoraCOM and supports the DICOM Basic Worklist Service Class and the DICOM Study Content Notification SOP Class. All operational parameters (such as AE titles, port numbers) can be accessed and changed by using the MedoraCOM Monitor application on a Windows® based system or by editing configuration files on Unix based systems.

MCSRVS provides Standard Conformance to the following DICOM SOP Class as an SCP:

Table 3-1

SOP Class Name	SOP Class UID	Role
Modality Worklist Management	1.2.840.10008.5.1.4.31	SCP
Basic Study Content Notification	1.2.840.10008.1.9	SCP
Verification	1.2.840.10008.1.1	SCP

3.2.1 Association Establishment Policies

3.2.1.1 General

MCSRVS accepts associations for the purposes of Modality Worklist Management - query and the Study Content Notification - store. MCSRVS accepts association requests from a remote DICOM AE only when it is registered in the configuration of MCSRVS (including AE Title (mandatory), optional TCP Port Number and Network Address) but MCSRVS does not initiate any association to a remote DICOM application entity.

The maximal PDU size, which MCSRVS supports, is configurable while the default value is 16 KB.

In general, MCSRVS obeys the association establishment policies of MedoraCOM.

3.2.1.2 Number of Associations

MCSRVS for UNIX® can accept and process multiple associations simultaneously. The maximum number of simultaneous associations is configurable. MedoraCOM Server will create a new process for each connection request it receives. MCSRVS for Windows® does not support simultaneous association handling.

3.2.1.3 Asynchronous Nature

MCSRVS will not perform asynchronous operations window negotiation.

3.2.1.4 Implementation Identifying Information

MCSRVS will provide a single Implementation Class UID of

”1.2.840.113619.6.95.31.0.3.4.1”

and an implementation version name of

”MDRCOM42”

3.2.2 Association Acceptance Policy

MCSRVS accepts associations for the purposes of retrieving worklist information, saving study, series and image information. MCSRVS accepts an association request only from remote DICOM application entities, which are known in the configuration of MedoraCOM.

For MCSRVS running on UNIX® the limitations on processing multiple associations simultaneously are adjustable.

3.2.2.1 Real-World Activities for Basic Modality Worklist

3.2.2.1.1 Associated Real-World Activities

MCSRVS supports a client to query the modality worklist database of the Centricity RISi. The client is usually an imaging modality or a system, which is delegated by imaging modalities. Each worklist item (organised as a Scheduled Procedure Step defined in the DICOM Standard) represents a scheduled imaging examination for a particular patient. To achieve a minimum of user interaction for assignments of PACS study objects to RIS study objects within a complete RIS-PACS workflow, it is recommended that all returned key attributes will be encoded in the generated images. Currently MCSRVS does not support more than one scheduled procedure step per requested procedure.

3.2.2.1.2 Presentation Context Table

For Basic Modality Worklist MCSRVS will accept the presentation contexts shown in the following table.

Table 3-2 Acceptable Presentation Contexts

Presentation Context Table					
Abstract Syntax		Transfer Syntax		Role	Extended Negotiation
Name	UID	Name	UID		

Modality Worklist Information Model – FIND	1.2.840.10008.5.1.4.31	DICOM Implicit VR Little Endian	1.2.840.10008.1.2	SCP	None
		DICOM Explicit VR Little Endian	1.2.840.10008.1.2.1		
		DICOM Explicit VR Big Endian	1.2.840.10008.1.2.2		

3.2.2.1.2.1 SOP Specific Conformance to the Modality Worklist Management SOP Class

MCSRVS supports the attributes listed in the following tables for matching and returning, respectively. MCSRVS does not support the attribute Specific Character Set (0008,0005) as matching key. The return value for this attribute is always ISO_IR 100.

The Centricity RISi Modality Worklist Server supports matching on the Matching Key Attributes listed in the following table.

Table 3-3 Supported Matching Key Attributes

Description / Module	Tag	Matching Key Type	Supported by Windows® Edition	Supported by Unix Edition
Scheduled Procedure Step			☒	☒
Scheduled Procedure Step Sequence	(0040,0100)	R	☒	☒
>Scheduled Station AE Title	(0040,0001)	R	☒	☒
>Scheduled Procedure Step Start Date	(0040,0002)	R	☒	☒
>Scheduled Procedure Step Start Time	(0040,0003)	R	☒	☒
>Modality	(0008,0060)	R	☒	☒
>Scheduled Station Name	(0040,0010)	O	☒	☒
>Scheduled Procedure Step Location	(0040,0011)	O	☒	☒
>Scheduled Performing Physician's Name	(0040,0006)	R	☒	☒
Patient Identification			☒	☒
Patient's Name	(0010,0010)	R	☒	☒
Patient ID	(0010,0020)	R	☒	☒
Imaging Service Request				
Accession Number	(0008,0050)	O	☒	☒
Patient Demographic				
Patients Birth Date	(0010,0030)	O	☒	☒
Patient Sex	(0010,0040)	O	☒	☒

The Centricity RISi Modality Worklist Server supports the Return Key Attributes listed in the following table.

Table 3-4 Supported Return Key Attributes

Description / Module	Tag	Return Key Type	Supported by Windows® Edition	Supported by Unix Edition
SOP Common			<input checked="" type="checkbox"/>	<input checked="" type="checkbox"/>
Specific Character Set	(0008,0005)	1C	<input checked="" type="checkbox"/>	<input checked="" type="checkbox"/>
Scheduled Procedure Step			<input checked="" type="checkbox"/>	<input checked="" type="checkbox"/>
Scheduled Procedure Step Sequence	(0040,0100)	1	<input checked="" type="checkbox"/>	<input checked="" type="checkbox"/>
>Scheduled Station AE Title	(0040,0001)	1	<input checked="" type="checkbox"/>	<input checked="" type="checkbox"/>
>Scheduled Procedure Step Start Date	(0040,0002)	1	<input checked="" type="checkbox"/>	<input checked="" type="checkbox"/>
>Scheduled Procedure Step Start Time	(0040,0003)	1	<input checked="" type="checkbox"/>	<input checked="" type="checkbox"/>
>Modality	(0008,0060)	1	<input checked="" type="checkbox"/>	<input checked="" type="checkbox"/>
>Scheduled Performing Physician's Name	(0040,0006)	2	<input checked="" type="checkbox"/>	<input checked="" type="checkbox"/>
>Scheduled Procedure Step Description	(0040,0007)	1C	<input checked="" type="checkbox"/>	<input checked="" type="checkbox"/>
>Scheduled Protocol Code Sequence	(0040,0008)	2	<input checked="" type="checkbox"/>	<input type="checkbox"/>
>>Code Value	(0008,0100)	1C	<input checked="" type="checkbox"/>	<input type="checkbox"/>
>>Coding Scheme Designator	(0008,0102)	1C	<input checked="" type="checkbox"/>	<input type="checkbox"/>
>>Code Meaning	(0008,0104)	3	<input checked="" type="checkbox"/>	<input type="checkbox"/>
>Scheduled Station Name	(0040,0010)	2	<input checked="" type="checkbox"/>	<input checked="" type="checkbox"/>
>Scheduled Procedure Step Location	(0040,0011)	2	<input checked="" type="checkbox"/>	<input checked="" type="checkbox"/>
>Pre-Medication	(0040,0012)	2C	<input checked="" type="checkbox"/>	<input checked="" type="checkbox"/>
>Scheduled Procedure Step ID	(0040,0009)	1	<input checked="" type="checkbox"/>	<input checked="" type="checkbox"/>
>Requested Contrast Agent	(0032,1070)	2C	<input checked="" type="checkbox"/>	<input checked="" type="checkbox"/>
>Comments on the Scheduled Procedure Step	(0040,0400)	3	<input checked="" type="checkbox"/>	<input checked="" type="checkbox"/>
Referenced Study Sequence	(0008,1110)	2	<input checked="" type="checkbox"/>	<input checked="" type="checkbox"/>
>Referenced SOP Class UID	(0008,1150)	1C	<input checked="" type="checkbox"/>	<input checked="" type="checkbox"/>
>Referenced SOP Instance UID	(0008,1155)	1C	<input checked="" type="checkbox"/>	<input checked="" type="checkbox"/>
Requested Procedure			<input checked="" type="checkbox"/>	<input checked="" type="checkbox"/>
Requested Procedure ID	(0040,1001)	1	<input checked="" type="checkbox"/>	<input checked="" type="checkbox"/>
Requested Procedure Code Sequence	(0032,1064)	1C	<input checked="" type="checkbox"/>	<input type="checkbox"/>
>Code Value	(0008,0100)	1C	<input checked="" type="checkbox"/>	<input type="checkbox"/>
>Coding Scheme Designator	(0008,0102)	1C	<input checked="" type="checkbox"/>	<input type="checkbox"/>
>Code Meaning	(0008,0104)	3	<input checked="" type="checkbox"/>	<input type="checkbox"/>

Description / Module	Tag	Return Key Type	Supported by Windows Edition	Supported by Unix Edition
Requested Procedure Description	(0032,1060)	1C	<input checked="" type="checkbox"/>	<input checked="" type="checkbox"/>
Study Instance UID	(0020,000D)	1	<input checked="" type="checkbox"/>	<input checked="" type="checkbox"/>
Requested Procedure Priority	(0040,1003)	2	<input checked="" type="checkbox"/>	<input checked="" type="checkbox"/>
Patient Transport Arrangements	(0040,1004)	2	<input checked="" type="checkbox"/>	<input checked="" type="checkbox"/>
Imaging Service Request			<input checked="" type="checkbox"/>	<input checked="" type="checkbox"/>
Accession Number	(0008,0050)	2	<input checked="" type="checkbox"/>	<input checked="" type="checkbox"/>
Requesting Physician	(0032,1032)	2	<input checked="" type="checkbox"/>	<input checked="" type="checkbox"/>
Referring Physician's Name	(0008,0090)	2	<input checked="" type="checkbox"/>	<input checked="" type="checkbox"/>
Placer Order Number / Imaging Service Request	(0040,2016)	3	<input checked="" type="checkbox"/>	<input type="checkbox"/>
Referring Physician's Name	(0008,0090)	2	<input checked="" type="checkbox"/>	<input checked="" type="checkbox"/>
Visit Identification			<input checked="" type="checkbox"/>	<input checked="" type="checkbox"/>
Admission ID	(0038,0010)	2	<input checked="" type="checkbox"/>	<input checked="" type="checkbox"/>
Visit Status			<input checked="" type="checkbox"/>	<input checked="" type="checkbox"/>
Current Patient Location	(0038,0300)	2	<input checked="" type="checkbox"/>	<input checked="" type="checkbox"/>
Visit Relationship			<input checked="" type="checkbox"/>	<input checked="" type="checkbox"/>
Referenced Patient Sequence	(0008,1120)	2	<input checked="" type="checkbox"/>	<input checked="" type="checkbox"/>
>Referenced SOP Class UID	(0008,1150)	1C	<input checked="" type="checkbox"/>	<input checked="" type="checkbox"/>
>Referenced SOP Instance UID	(0008,1155)	1C	<input checked="" type="checkbox"/>	<input checked="" type="checkbox"/>
Patient Identification			<input checked="" type="checkbox"/>	<input checked="" type="checkbox"/>
Patient's Name	(0010,0010)	1	<input checked="" type="checkbox"/>	<input checked="" type="checkbox"/>
Patient ID	(0010,0020)	1	<input checked="" type="checkbox"/>	<input checked="" type="checkbox"/>
Patient Demographic			<input checked="" type="checkbox"/>	<input checked="" type="checkbox"/>
Patients Birth Date	(0010,0030)	2	<input checked="" type="checkbox"/>	<input checked="" type="checkbox"/>
Patient's Sex	(0010,0040)	2	<input checked="" type="checkbox"/>	<input checked="" type="checkbox"/>
Patient's Weight	(0010,1030)	2	<input checked="" type="checkbox"/>	<input checked="" type="checkbox"/>
Confidentiality constraint on patient data	(0040,3001)	2	<input checked="" type="checkbox"/>	<input checked="" type="checkbox"/>
Patient Medical			<input checked="" type="checkbox"/>	<input checked="" type="checkbox"/>
Patient State	(0038,0500)	2	<input checked="" type="checkbox"/>	<input checked="" type="checkbox"/>
Pregnancy Status	(0010,21C0)	2	<input checked="" type="checkbox"/>	<input checked="" type="checkbox"/>

Description / Module	Tag	Return Key Type	Supported by Windows Edition	Supported by Unix Edition
Medical Alerts	(0010,2000)	2	☒	☒
Contrast Allergies	(0010,2110)	2	☒	☒
Special Needs	(0038,0050)	2	☒	☒

3.2.2.2 Real-World Activities for Basic Study Content Notification

3.2.2.2.1 Associated Real-World Activities

The associated Real-World Activity is to notify the RIS on the content of an imaging study.

3.2.2.2.2 Presentation Context Table

For Basic Study Content Notification MCSRVR will accept any of the presentation contexts shown in the following table.

Table 3-5 Acceptable Presentation Contexts

Presentation Context Table					
Abstract Syntax		Transfer Syntax		Role	Extended Negotiation
Name	UID	Name	UID		
Basic Study Content Notification SOP Classes	1.2.840.10008.1.9	DICOM Implicit VR Little Endian	1.2.840.10008.1.2	SCP	None
		DICOM Explicit VR Little Endian	1.2.840.10008.1.2.1		
		DICOM Explicit VR Big Endian	1.2.840.10008.1.2.2		

3.2.2.2.2.1 SOP Specific Conformance to the Study Content Notification SOP Class

MCSRVR provides the Standard Conformance to the DICOM Study Content Notification Service Class.

In the event of a successful C-STORE operation, MCSRVR saves all UIDs identifying the notified imaging study in the RIS and uses the Study Instance UID and the patient information for trying to build a link between the study and a study object in the RIS. The RIS may use these UIDs to move the images at a later time.

In order to facilitate to link the notified imaging study appropriately to a study object in the RIS, this implementation of MCSRVR prefers that the remote DICOM application should submit a Basic Study Content Notification IOD instance with some extension, which is listed in the next chapter. In general, MCSCNP can handle any additional attributes included in the SOP instance. Those attributes not listed in Table 3-7 Additional Attributes in the Basic Study Content Notification IOD Supported by MCSRVR will be simply ignored.

The SCP behaviour as a result of receiving the Study Content Notification information consists of storing study, series and image identification data in the RIS database to provide the ability studies, series

and/or images to be retrieved by the RIS. Therefore the SCP support the 2C attribute Retrieve AE title (0008,0054).

MCSRVS returns one of the following status codes to indicate an unsuccessful the C-STORE:

Table 3-6 Reponse Codes

Response Code	Status	Further Meaning
0000	Success	Complete Study Content exists on RIS
A700	Out of Resources	Indicates that there was not enough disk space to store the information included in the SOP instance. Recovery from this condition is left to the administrator of MedoraCOM.
A800	SOP Class Not Supported	Indicates that the SOP Class of the instance dataset in the C-STORE operation did not match the Abstract Syntax negotiated for the Presentation Context. This indicates a problem with the SCU of the Service Class.
A900	Data Set does not match SOP Class	Indicates that the Data Set does not encode an instance of the SOP Class specified. This indicates a problem with SCU of the Service Class.
C000	Cannot understand	Indicates that the Data Set cannot be parsed into elements by MCSCN. This indicates a problem with the SCU.

3.2.2.2.2.2 Extension of the Basic Study Content Notification IOD

MCSRVS supports the following additional data attributes in a DICOM Standard Extended Basic Study Content Notification IOD instances:

Table 3-7 Additional Attributes in the Basic Study Content Notification IOD Supported by MCSRVS

Description / Module	Tag	Supported by Windows Edition	Supported by Unix Edition
Study Level			
Accession Number	(0008,0050)	☒	☒
Study Date	(0008,0020)	☒	☒
Study Time	(0008,0030)	☒	☒
Study Description	(0008,1030)	☒	☒
Series Level			
Modality	(0008,0060)	☒	☒
Series Date	(0008,0021)	☒	☒

Description / Module	Tag	Supported by Windows Edition	Supported by Unix Edition
Series Time	(0008,0031)	☒	☒
Series Description	(0008,103E)	☒	☒

MCSRVS will make use of these additional data attributes to facilitate the link between the notified imaging study and a study object in the RIS.

3.2.2.3 Real-World Activities for Verification

3.2.2.3.1 Associated Real-World Activities

MCSRVS allows another DICOM application to verify whether a DICOM association can be established between MCSRVS and the application.

3.2.2.3.2 Presentation Context Table

For Verification MCSRVS will accept the presentation contexts shown in the following table.

Table 3-8 Acceptable Presentation Contexts

Presentation Context Table					
Abstract Syntax		Transfer Syntax		Role	Extended Negotiation
Name	UID	Name	UID		
Verification	1.2.840.10008.1.1	DICOM Implicit VR Little Endian	1.2.840.10008.1.2	SCP	None
		DICOM Explicit VR Little Endian	1.2.840.10008.1.2.1		
		DICOM Explicit VR Big Endian	1.2.840.10008.1.2.2		

3.2.2.3.2.1 SOP Specific Conformance to the Verification SOP Class

MCSRVS provides standard conformance.

3.2.2.3.3 Presentation Context Acceptance Criterion

MCSRVS will always accept a Presentation Context for the Modality Worklist SOP Class, the Study Content Notification SOP Class and the Verification SOP Class with the DICOM Default Transfer Syntax.

MCSRVS will accept any number of presentation contexts specified in Table 3-2, Table 3-5 and Table 3-8. MCSRVS will examine proposed Presentation contexts in the order proposed. For the presentation contexts of the same abstract syntax but different transfer syntaxes, only one of these presentation contexts will be accepted with the most preferred transfer syntax chosen by MCSRVS. The policy of making this choice is described in the next section.

3.2.2.3.4 Transfer Syntax Selection Policy

MCSRVS selects the transfer syntax to accept for the worklist query, receiving study information or retrieving a diagnostic report with the following general rules: First of all, it prefers a transfer syntax, which provides the explicit VR representation. After the VR choice has been made, MCSRVS tries to select the transfer syntax using following preference in descending order:

1. Explicit VR Little Endian
2. Explicit VR Big Endian
3. Implicit VR Little Endian

Different Transfer Syntaxes will not be selected.

4 MEDORACOM IMAGE QUERY/RETRIEVE SERVICES

4.1 IMPLEMENTATION MODEL

The Centricity RISi application provides a user interface for defining pre-fetching and auto-routing rules and initiating image retrieval on demand. The user-defined rules are stored in several tables of the RIS database. The detailed specification is already available within the Centricity RISi user manual. Therefore only main issues shall be discussed within this document. Using the study, series and image information received either by the study content notification or by a query using C-FIND the RIS is able to control the image workflow by supporting mechanisms to automatically auto-route and pre-fetch of images as well as transfer images on demand. Therefore the DIMSE service C-FIND is used to gain the study, series and image information and the C-MOVE is used to request sending the images to any DICOM node known by the RIS.

4.1.1 Application Data Flow Diagram

MedoraCOM Query/Retrieve Services (MCQRS) are WIN 32 processes that are controlled by RIS-PACS Communication Manager service able to run on a Microsoft Windows®.

MCQRS initiates an association to a remote DICOM Application Entity (PACS or other IS). If the association is accepted by the remote AE, MCQRS sends either image query request or an image retrieve request based on one of the supported DICOM Retrieve Information Model (see later) by specifying the move destination.

Illustration 4-1

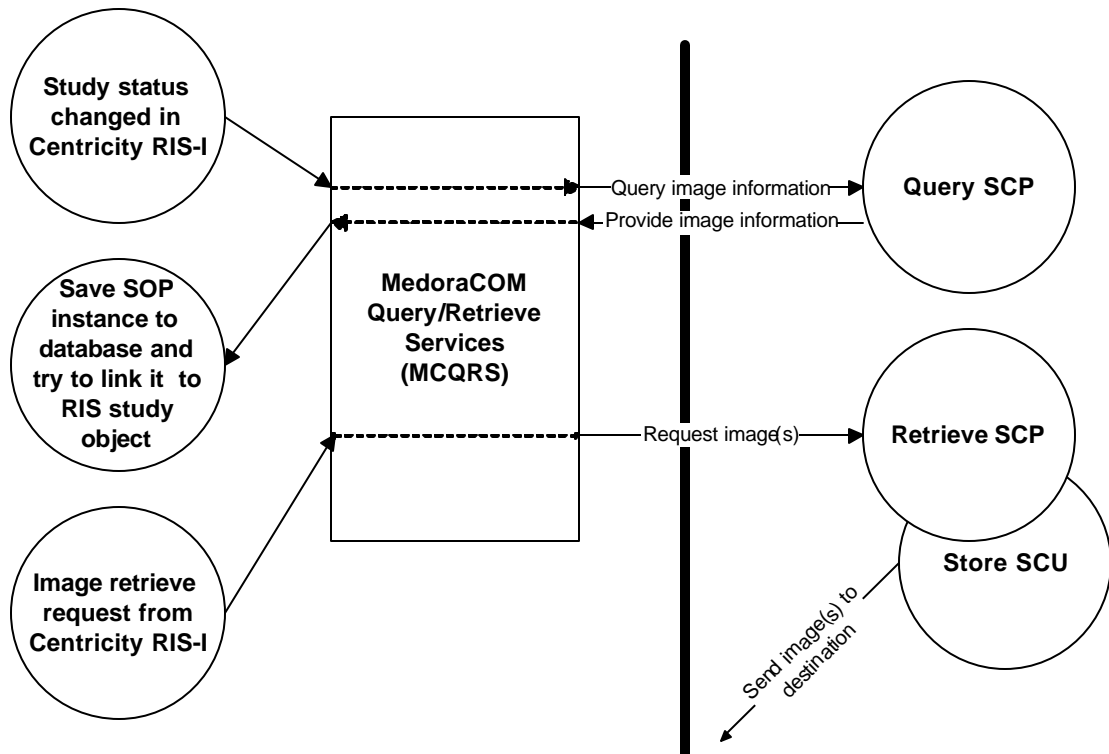

4.1.2 Functional Definition of AE

MedoraCOM Query/Retrieve Services may be automatically started when the machine is booted or it may be started when the Centricity RISi server processes are launched. Upon a service request coming from the Centricity RISi System, MCQRS is triggered to perform the DIMSE service operation.

Having been triggered, MCQRS initiates an association to the remote DICOM AE (PACS or other IS) which parameters are defined during the installation of MedoraCOM. If there are more than one remote DICOM AEs to which the Centricity RISi System wants to communicate through MedoraCOM, a concrete remote AE shall be specified with the trigger event. If the association is successfully accepted by the remote AE, MCQRS then performs the concrete job specified in the request.

4.1.3 Sequencing of Real-World Activities

MedoraCom can be set up to perform a image query to a remote DICOM AE for getting study, series and image information similar to the DICOM study contents notification. MedoraCom can be configured to initiate a query after the RIS study status has been changed to

- Patient arrived
- Study started
- Study completed
- Report transcribed and
- Report approved.

MCQRS also performs image retrieve requests. In case of unsuccessful completion MedoraCOM will retry the operation certain times or for a certain time depending on the configuration of MedoraCOM.

4.2 APPLICATION ENTITY SPECIFICATION

As stated previously, MCQRS is a component of MedoraCOM and can be configured to operate as one DICOM AE or separate AEs, according to the demand of the user. Usually, all MedoraCOM components run under one AE Title.

All operational parameters (such as AE titles, port numbers) of MCQRS are saved in the configuration data files or the Windows® registry database of MedoraCOM.

4.2.1 Association Establishment Policies

MCQRS provides Standard Conformance to the following DICOM SOP Class as an SCU:

Table 4-1

SOP Class Name	SOP Class UID	Role
Study Root Query / Retrieve Information Model - FIND	1.2.840.10008.5.1.4.1.2.2.1	SCU
Study Root Query / Retrieve	1.2.840.10008. 5.1.4.1.2.2.2	SCU

Information Model - MOVE		
--------------------------	--	--

4.2.1.1 General

MCQRS will attempt to establish an association whenever a request is coming from the Centricity RISi System with all valid parameters, including the AE title, TCP port number, host name and network address. It will only attempt to establish associations if it determines that the request / retrieve parameters are valid with respect to this Conformance Statement.

The maximum PDU size that MCQRS will use is configurable.

4.2.1.2 Number of Associations

MedoraCOM keeps at most four instances of MCQRS running - one for querying a remote AE, one for image auto-routing, one for image pre-fetching and one for image transfer on demand - simultaneously. If a new request comes when such an association is still in process, the new request is queued and will be processed later.

4.2.1.3 Asynchronous Nature

(MCQRS) will not perform asynchronous operations.

4.2.1.4 Implementation Identifying Information

(MCDMS) will provide a single Implementation Class UID of

”1.2.840.113619.6.95.31.0.3.4.1”

and an implementation version name of

”MDRCOM42”

4.2.2 Association Initiation Policy

MedoraCOM Query/Retrieve Services (MCQRS) attempt to initiate a new association each time it is requested by the internal event management of Centricity RISi.

4.2.2.1 Real-World Activities for Query Request (C-FIND)

4.2.2.1.1 Associated Real-World Activities

The associated Real-World Activity is to gain study, series and/or image information from remote using DIMSE-C-FIND applications. If the information is successfully received, MCQRS saves the study information in the Centricity RISi database and tries to build a link between the received study to the corresponding study object in the RIS.

4.2.2.1.2 Proposed Presentation Contexts

MCQRS-FIND will propose the Presentation Contexts shown in Table 4-2 Proposed Presentation Context of MCQRS for a C-FIND.

Table 4-2 Proposed Presentation Context of MCQRS for a C-FIND

Presentation Context Table					
Abstract Syntax		Transfer Syntax		Role	Extended Negotiation
Name	UID	Name List	UID List		
Study Root Query / Retrieve Information Model - FIND	1.2.840.10008.5.1.4.1.2.2.1	DICOM Explicit VR Little Endian	1.2.840.10008.1.2.1	SCU	None
		DICOM Explicit VR Big Endian	1.2.840.10008.1.2.2		
		DICOM Implicit VR Little Endian	1.2.840.10008.1.2		

4.2.2.1.2.1 SOP Specific Conformance

MCQRS provides standard conformance to the DICOM Query / Retrieve Service Class.

MCQRS does not provide extended negotiation and does not use relational retrieve. It uses only hierarchical query/retrieve on study, series or image levels.

Table 4-3 Keys Used by a Query Issued by MCQRS

Key	Tag	Level	Matching Key	Return Key	Supported by Windows® Edition	Supported by Unix Edition	Type of Matching
Study Instance UID	(0020,000D)	STUDY	4	4	<input checked="" type="checkbox"/>	<input type="checkbox"/>	Single Value
Study ID	(0020,0010)	SERIES	4	4	<input checked="" type="checkbox"/>	<input type="checkbox"/>	Single Value
Study Date	(0008,0020)	STUDY		4	<input checked="" type="checkbox"/>	<input type="checkbox"/>	Universal
Accession Number	(0008,0050)	STUDY	4	4	<input checked="" type="checkbox"/>	<input type="checkbox"/>	Single Value
Series Instance UID	(0020,000E)	SERIES	4	4	<input checked="" type="checkbox"/>	<input type="checkbox"/>	Single Value
Series Number	(0020,0011)	IMAGE		4	<input checked="" type="checkbox"/>	<input type="checkbox"/>	Universal
Modality	(0008,0060)	SERIES		4	<input checked="" type="checkbox"/>	<input type="checkbox"/>	Universal
Instance Number	(0020,0013)	IMAGE		4	<input checked="" type="checkbox"/>	<input type="checkbox"/>	Universal
Overlay Number	(0020,0022)	IMAGE		4	<input checked="" type="checkbox"/>	<input type="checkbox"/>	Universal
Curve Number	(0020,0024)	IMAGE		4	<input checked="" type="checkbox"/>	<input type="checkbox"/>	Universal
Lookup Table Number	(0020,0026)	IMAGE		4	<input checked="" type="checkbox"/>	<input type="checkbox"/>	Universal
SOP Instance UID	(0008,0018)	IMAGE		4	<input checked="" type="checkbox"/>	<input type="checkbox"/>	Universal

4.2.2.2 Real-World Activities for Image Retrieve Request

4.2.2.2.1 Associated Real-World Activities

The associated Real-World Activity is the attempt to perform the service operation DIMSE-C-MOVE issued by MedoraCOM. If MCQRS successfully establishes an association to a remote AE, it will request it to move images to the specified destination.

MedoraCOM will be informed about the move results.

4.2.2.2.2 Proposed Presentation Contexts

MCQRS-MOVE will propose the Presentation Contexts shown in Table 4-4 Proposed Presentation Context of MCQRS for a C-MOVE.

Table 4-4 Proposed Presentation Context of MCQRS for a C-MOVE

Presentation Context Table					
Abstract Syntax		Transfer Syntax		Role	Extended Negotiation
Name	UID	Name List	UID List		
Study Root	1.2.840.10008.5.	DICOM Explicit VR Little Endian	1.2.840.10008.1.2.1	SCU	None
Query / Retrieve Information Model - FIND	1.4.1.2.2.1	DICOM Explicit VR Big Endian	1.2.840.10008.1.2.2		
		DICOM Implicit VR Little Endian	1.2.840.10008.1.2		

4.2.2.2.2.1 SOP Specific Conformance

MCQRS provides standard conformance to the DICOM Query / Retrieve Service Class.

MCQRS does not provide extended negotiation and does not use relational retrieve. It uses only hierarchical query/retrieve on study, series or image levels.

5 MEDORACOM PPS MANAGER

This chapter gives the technical specification of the MedoraCOM PPS Manager (MCPPS) - a part of the DICOM communication interface of GE's Radiology Information System Centricity RISi.

MCPPS implements a PPS Manager as defined in the IHE Year 2 Technical Framework. It consists of two processes one provides a DICOM Modality Performed Procedure Step SCP listening on a TCP port waiting for DICOM associations requested by SCUs. If configured this process tries to act also as an SCU in order to forward the received messages to a third system. The second process provides a DICOM Modality Performed Procedure Step SCU in order to send PPS messages to a third system in case the first attempt which is carried out by the PPS Manager process directly after reception has failed.

Usually MCPPS supports a single application entity titles (AET) but MCPPS SCP and MCPPS SCU may also be configured to support two different application entity titles.

5.1 IMPLEMENTATION MODEL

The component MCPPS has been implemented to act as a Service Class Provider (SCP) and a Service Class User of the DICOM MPPS Service Class. The MedoraCOM PPS Manager is only available on Windows®.

The MedoraCOM PPS Manager supports one AE Title. The AE Title can be the same AE Title that other components of MedoraCOM support, or another specialised AE Title.

5.1.1 Application Data Flow Diagram

MCPPS consists of two WIN 32 processes controlled by the RIS-PACS Communication Manager service, which are able to run on any Microsoft Windows®.

MedoraCOM PPS Manager may be automatically started when the machine is booted or it may be started when the Centricity RISi server processes are launched what means that no user login is required.

A remote DICOM Application Entity initiates an association for a DICOM Modality Performed Procedure Step Service Class.

When MCPPS accepts the association, the remote AE transmits the MPPS message to MCPPS. If configured MCPPS is acting as DICOM Modality Performed Procedure Step SCU sending the PPS messages to a third system. The received data is stored in the RIS database and if possible automatically assigned to a patient/procedure in Centricity RISi.

Illustration 5-1

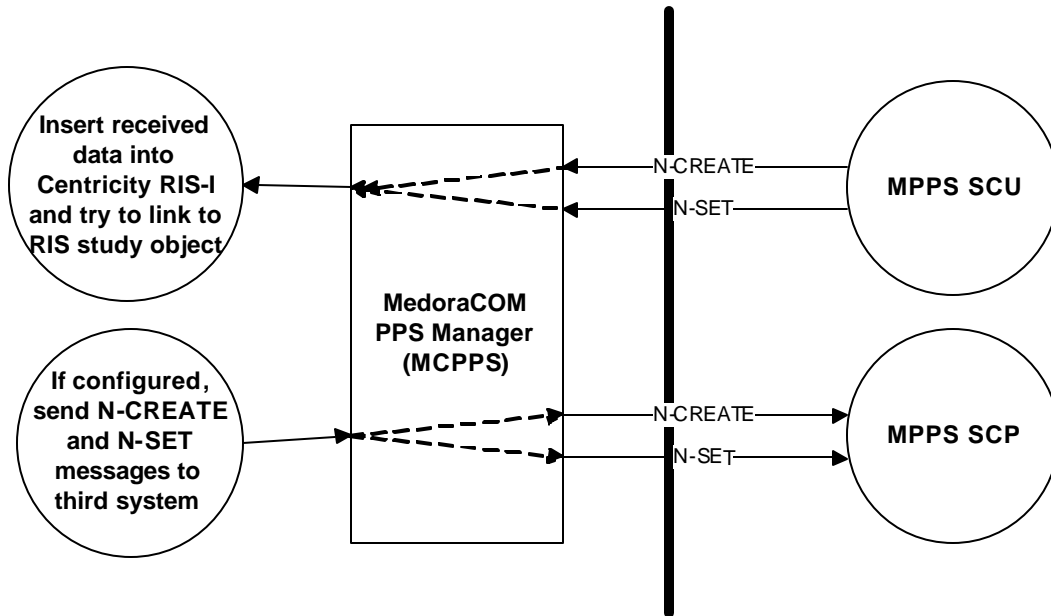

5.1.2 Functional Definition of AE

After being started, MCPPS is always waiting for an association request from a remote DICOM application entity. MCPPS will accept an association with the supported SOP class only for those remote DICOM applications, which are specified in the configuration of MedoraCOM. This means that not all remote DICOM application entities are permitted to transmit PPS messages to MedoraCOM.

5.1.3 Sequencing of Real-World Activities

Normally the medical modality (MPPS SCU) indicates

- the beginning of the PPS by sending a N-CREATE message to the MPPS SCP
- and the end of the PPS by sending a N-SET message with the status “DISCONTINUED” or “COMPLETED”

If MCPPS receives a valid Modality Performed Procedure Step SOP instance the information is stored into a structure of several database tables directly depicting the structure of the DICOM Modality Performed Procedure Step SOP Class and - if configured - forwarded to a third device. If possible the received MPPS SOP instance is assigned to a previously scheduled procedure step in the database of Centricity RISi.

5.2 APPLICATION ENTITY SPECIFICATION

MCPPS is one functional component of MedoraCOM and supports the DICOM Modality Performed Procedure Step Service Class.

All operational parameters (such as AE titles, port numbers) can be accessed and changed by using the MedoraCOM Monitor application on a Windows® based system.

5.2.1 Association Establishment Policies

MCPPS provides Standard Conformance to the following DICOM SOP Class as an SCP and SCU:

Table 5-1

SOP Class Name	SOP Class UID	Role
Modality Performed Procedure Step	1.2.840.10008.3.1.2.3.3	SCP
Modality Performed Procedure Step	1.2.840.10008.3.1.2.3.3	SCU

5.2.1.1 General

MCPPS accepts associations for the purposes of Modality Performed Procedure Step SOP Class. MCPPS accepts association requests from a remote DICOM AE only when it is registered in the configuration of MCPPS (including AE Title (mandatory), optional TCP Port Number and Network Address).

If configured, MCPPS also will attempt to establish an association to the configured peer SCP whenever a valid N-CREATE or N-SET message is received from the PPS Manager SCP.

The maximal PDU size, which MCPPS supports, is configurable while the default value is 16 KB.

In general, MCPPS obeys the association establishment policies of MedoraCOM.

5.2.1.2 Number of Associations

MCPPS can accept and process multiple associations simultaneously. The maximum number of simultaneous associations is configurable. MedoraCOM PPS Manager will create a new process for each connection request it receives.

5.2.1.3 Asynchronous Nature

MCPPS will not perform asynchronous operations window negotiation.

5.2.1.4 Implementation Identifying Information

MCPPS will provide a single Implementation Class UID of

”1.2.840.113619.6.95.31.0.3.4.1”

and an implementation version name of

”MDRCOM42”

5.2.2 Association Acceptance Policy

MCPPS accepts associations for the purposes of receiving modality performed procedure step information. MCPPS accepts an association request only from remote DICOM application entities, which are known in the configuration of MedoraCOM.

5.2.2.1 Real-World Activity MPPS SCP

5.2.2.1.1 Associated Real-World Activity

After an imaging modality has started the performance of a Procedure Step it should inform the IS by sending an N-CREATE service request to MCPPS (SCP). At the end of the Performed Procedure Step the imaging modality shall send a N-SET command with all other mandatory attributes to MCPPS (SCP).

If MCPPS (SCP) receives a valid Modality Performed Procedure Step SOP instance the information is stored into a structure of several database tables directly depicting the structure of the DICOM Modality Performed Procedure Step SOP Class. If possible the received MPPS SOP instance is assigned to a previously scheduled procedure step in the database of Centricity RISi.

5.2.2.1.2 Presentation Context Table

MCPPS (SCP) will accept of the presentation contexts shown in the following table.

Table 5-2 Acceptable Presentation Contexts for MCPPS

Presentation Context Table					
Abstract Syntax		Transfer Syntax		Role	Extended Negotiation
Name	UID	Name	UID		
Modality Performed Procedure Step SOP Class	1.2.840.10008.3.1.2.3.3	DICOM Implicit VR Little Endian	1.2.840.10008.1.2	SCP	None
		DICOM Explicit VR Little Endian	1.2.840.10008.1.2.1		
		DICOM Explicit VR Big Endian	1.2.840.10008.1.2.2		

5.2.2.1.2.1 SOP Specific Conformance

MCPPS provides the Standard Conformance to the DICOM Modality Performed Procedure Step Service Class as an SCP.

Description / Module	Tag	Type N-CREATE SCU/SCP	Type N-SET SCU/SCP	Requirement Type Final State ¹	Supported by Windows® Edition	Supported by Unix Edition
SOP Common Module					<input checked="" type="checkbox"/>	<input type="checkbox"/>
SOP Class UID	(0008,0016)	3/3	3/3		<input checked="" type="checkbox"/>	<input type="checkbox"/>
SOP Instance UID	(0008,0018)	3/3	3/3		<input checked="" type="checkbox"/>	<input type="checkbox"/>

¹ The requirement for the final state is that which applies at the time that the Performed Procedure Step Status (0040,0252) is N-SET to a value of COMPLETED or DISCONTINUED, as described in F.7.2.2.2. It is only described if it is different from the SCP requirement for the N-CREATE.

Description / Module	Tag	Type N-CREATE SCU/SCP	Type N-SET SCU/SCP	Re- quire- ment Type Final State ¹	Supported by Windows® Edition	Supported by Unix Edition
Specific Character Set	(0008,0005)	1C/1C (Required if an extended or replacement character set is used)	Not allowed		<input checked="" type="checkbox"/>	<input type="checkbox"/>
Instance Creation Date	(0008,0012)	3/3	3/3		<input checked="" type="checkbox"/>	<input type="checkbox"/>
Instance Creation Time	(0008,0013)	3/3	3/3		<input checked="" type="checkbox"/>	<input type="checkbox"/>
Instance Creator UID	(0008,0014)	3/3	3/3		<input checked="" type="checkbox"/>	<input type="checkbox"/>
Performed Procedure Step Relationship Mod- ule					<input checked="" type="checkbox"/>	<input type="checkbox"/>
Patient's Name	(0010,0010)	3/3 ²	Not allowed		<input checked="" type="checkbox"/>	<input type="checkbox"/>
Patient ID	(0010,0020)	3/3 ²	Not allowed		<input checked="" type="checkbox"/>	<input type="checkbox"/>
Patient's Birth Date	(0010,0030)	3/3 ²	Not allowed		<input checked="" type="checkbox"/>	<input type="checkbox"/>
Patient's Sex	(0010,0040)	3/3 ²	Not allowed		<input checked="" type="checkbox"/>	<input type="checkbox"/>
Referenced Patient Se- quence	(0008,1120)	3/3 ²	Not allowed		<input checked="" type="checkbox"/>	<input type="checkbox"/>
>Referenced SOP Class UID	(0008,1150)	1C/1C	Not allowed		<input checked="" type="checkbox"/>	<input type="checkbox"/>
>Referenced SOP Instance UID	(0008,1155)	1C/1C	Not allowed		<input checked="" type="checkbox"/>	<input type="checkbox"/>
Scheduled Step Attribute Sequence	(0040,0270)	1/1	Not allowed		<input checked="" type="checkbox"/>	<input type="checkbox"/>
>Study Instance UID	(0020,000D)	1/1	Not allowed		<input checked="" type="checkbox"/>	<input type="checkbox"/>
>Referenced Study Se- quence	(0008,1110)	3/3 ²	Not allowed		<input checked="" type="checkbox"/>	<input type="checkbox"/>

² The original attribute type defined in the DICOM Standard is 2/2 or 2C/2. The PPS Manager SCP handles these attributes like type 3 attributes in case some tags are missing. **However** the PPS Manager SCU forwards the message as it was received by the SCP, what means that the PPS Manager does not add any information that is missing.

Description / Module	Tag	Type N-CREATE SCU/SCP	Type N-SET SCU/SCP	Re- quire- ment Type Final State ¹	Supported by Windows® Edition	Supported by Unix Edition
>>Referenced SOP Class UID	(0008,1150)	1C/1C	Not allowed		<input checked="" type="checkbox"/>	<input type="checkbox"/>
>>Referenced SOP In- stance UID	(0008,1155)	1C/1C	Not allowed		<input checked="" type="checkbox"/>	<input type="checkbox"/>
>Accession Number	(0008,0050)	3/3 ²	Not allowed		<input checked="" type="checkbox"/>	<input type="checkbox"/>
>Placer Order Number/ Imaging Service Request	(0040,2006)	3/3	Not allowed		<input checked="" type="checkbox"/>	<input type="checkbox"/>
>Filler Order Number/ Imaging Service Request	(0040,2007)	3/3	Not allowed		<input checked="" type="checkbox"/>	<input type="checkbox"/>
>Requested Procedure ID	(0040,1001)	3/3 ²	Not allowed		<input checked="" type="checkbox"/>	<input type="checkbox"/>
>Requested Procedure Description	(0032,1060)	3/3 ²	Not allowed		<input checked="" type="checkbox"/>	<input type="checkbox"/>
>Placer Order Number/ Procedure	(0040,1006)	3/3	Not allowed		<input checked="" type="checkbox"/>	<input type="checkbox"/>
>Filler Order Number/ Procedure	(0040,1007)	3/3	Not allowed		<input checked="" type="checkbox"/>	<input type="checkbox"/>
>Scheduled Procedure Step ID	(0040,0009)	3/3 ²	Not allowed		<input checked="" type="checkbox"/>	<input type="checkbox"/>
>Scheduled Procedure Step Description	(0040,0007)	3/3 ²	Not allowed		<input checked="" type="checkbox"/>	<input type="checkbox"/>
>Scheduled Action Item Code Sequence	(0040,0008)	3/3 ²	Not allowed		<input checked="" type="checkbox"/>	<input type="checkbox"/>
>>Code Value	(0008,0100)	1C/1C	Not allowed		<input checked="" type="checkbox"/>	<input type="checkbox"/>
>>Coding Scheme designa- tor	(0008,0102)	1C/1C	Not allowed		<input checked="" type="checkbox"/>	<input type="checkbox"/>
>>Code Meaning	(0008,0104)	3/3	Not allowed		<input checked="" type="checkbox"/>	<input type="checkbox"/>
Performed Procedure Step Information					<input checked="" type="checkbox"/>	<input type="checkbox"/>
Performed Procedure Step ID	(0040,0253)	1/1	Not allowed		<input checked="" type="checkbox"/>	<input type="checkbox"/>
Performed Station AE Title	(0040,0241)	1/1	Not allowed		<input checked="" type="checkbox"/>	<input type="checkbox"/>

Description / Module	Tag	Type N-CREATE SCU/SCP	Type N-SET SCU/SCP	Re- quire- ment Type Final State ¹	Supported by Windows® Edition	Supported by Unix Edition
Performed Station Name	(0040,0242)	3/3 ²	Not allowed		<input checked="" type="checkbox"/>	<input type="checkbox"/>
Performed Location	(0040,0243)	3/3 ²	Not allowed		<input checked="" type="checkbox"/>	<input type="checkbox"/>
Performed Procedure Step Start Date	(0040,0244)	1/1	Not allowed		<input checked="" type="checkbox"/>	<input type="checkbox"/>
Performed Procedure Step Start Time	(0040,0245)	1/1	Not allowed		<input checked="" type="checkbox"/>	<input type="checkbox"/>
Performed Procedure Step Status	(0040,0252)	1/1	3/1		<input checked="" type="checkbox"/>	<input type="checkbox"/>
Performed Procedure Step Description	(0040,0254)	3/3 ²	3/2		<input checked="" type="checkbox"/>	<input type="checkbox"/>
Performed Procedure Type Description	(0040,0255)	3/3 ²	3/2		<input checked="" type="checkbox"/>	<input type="checkbox"/>
Procedure Code Sequence	(0008,1032)	3/3 ²	3/2		<input checked="" type="checkbox"/>	<input type="checkbox"/>
>Code Value	(0008,0100)	1C/1 (Required if Sequence Item is present)	1C/1 (Required if Sequence Item is present)		<input checked="" type="checkbox"/>	<input type="checkbox"/>
>Coding Scheme Designator	(0008,0102)	1C/1 (Required if Sequence Item is pre- sent)	1C/1 (Required if Sequence Item is present)		<input checked="" type="checkbox"/>	<input type="checkbox"/>
>Code Meaning	(0008,0104)	3/3	3/3		<input checked="" type="checkbox"/>	<input type="checkbox"/>
Performed Procedure Step End Date	(0040,0250)	3/3 ²	3/1	1	<input checked="" type="checkbox"/>	<input type="checkbox"/>
Performed Procedure Step End Time	(0040,0251)	3/3 ²	3/1	1	<input checked="" type="checkbox"/>	<input type="checkbox"/>
Performed Procedure Step End Time	(0040,0251)	3/3 ²	3/1	1	<input checked="" type="checkbox"/>	<input type="checkbox"/>
Comments on the Per- formed Procedure Step	(0040,0280)	3/3	3/3		<input checked="" type="checkbox"/>	<input type="checkbox"/>
Performed Procedure Step Discontinuation Reason Code Sequence	(0040,0281)	3/3	3/3		<input checked="" type="checkbox"/>	<input type="checkbox"/>

Description / Module	Tag	Type N-CREATE SCU/SCP	Type N-SET SCU/SCP	Re- quire- ment Type Final State ¹	Supported by Windows® Edition	Supported by Unix Edition
>Code Value	(0008,0100)	1C/1 (Required if Sequence Item is present)	1C/1 (Required if Sequence Item is present)		<input checked="" type="checkbox"/>	<input type="checkbox"/>
>Coding Scheme Designator	(0008,0102)	1C/1 (Required if Sequence Item is pre- sent)	1C/1 (Required if Sequence Item is present)		<input checked="" type="checkbox"/>	<input type="checkbox"/>
>Code Meaning	(0008,0104)	3/3	3/3		<input checked="" type="checkbox"/>	<input type="checkbox"/>
Image Acquisition Re- sults					<input checked="" type="checkbox"/>	<input type="checkbox"/>
Modality	(0008,0060)	1/1	Not allowed		<input checked="" type="checkbox"/>	<input type="checkbox"/>
Study ID	(0020,0010)	3/3 ²	Not allowed		<input checked="" type="checkbox"/>	<input type="checkbox"/>
Performed Protocol Code Sequence	(0040,0260)	3/3 ²	3/2		<input checked="" type="checkbox"/>	<input type="checkbox"/>
>Code Value	(0008,0100)	1C/1 (Required if Sequence Item is pre- sent)	1C/1 (Required if Sequence Item is present)		<input checked="" type="checkbox"/>	<input type="checkbox"/>
>Coding Scheme Designator	(0008,0102)	1C/1 (Required if Sequence Item is pre- sent)	1C/1 (Required if Sequence Item is present)		<input checked="" type="checkbox"/>	<input type="checkbox"/>
>Code Meaning	(0008,0104)	3/3	3/3		<input checked="" type="checkbox"/>	<input type="checkbox"/>
Performed Series Sequence	(0040,0340)	3/3 ²	3/1	1 ³	<input checked="" type="checkbox"/>	<input type="checkbox"/>
>Performing Physician's Name	(0008,1050)	3/3 ²	3/3 ²	2	<input checked="" type="checkbox"/>	<input type="checkbox"/>

³ The Performed Series Sequence (0040,0340) may not be empty (zero length) at the time that the Performed Procedure Step Status (0040,0252) is N-SET to a value of COMPLETED or DISCONTINUED. In other words a Series must exist for every Performed Procedure Step, though it may contain no Images or Standalone objects, if none were created, as described in F.7.2.2.2. (DICOM Standard).

Description / Module	Tag	Type N-CREATE SCU/SCP	Type N-SET SCU/SCP	Re- quire- ment Type Final State ¹	Supported by Windows® Edition	Supported by Unix Edition
>Performing Physician Identification Sequence	(0008,1052)	3/3	3/3		<input checked="" type="checkbox"/>	<input type="checkbox"/>
>>Person Identification Code Sequence	(0040,1101)	1/1	1/1		<input checked="" type="checkbox"/>	<input type="checkbox"/>
>>>Code Value	(0008,0100)	1C/1 (Required if Sequence Item is present)	1C/1 (Required if Sequence Item is present)		<input checked="" type="checkbox"/>	<input type="checkbox"/>
>>>Coding Scheme Designator	(0008,0102)	1C/1 (Required if Sequence Item is present)	1C/1 (Required if Sequence Item is present)		<input checked="" type="checkbox"/>	<input type="checkbox"/>
>>>Code Meaning	(0008,0104)	3/3	3/3		<input checked="" type="checkbox"/>	<input type="checkbox"/>
>>Person's Address	(0040,1102)	3/3	3/3		<input checked="" type="checkbox"/>	<input type="checkbox"/>
>>Person's Telephone Numbers	(0040,1103)	3/3	3/3		<input checked="" type="checkbox"/>	<input type="checkbox"/>
>>Institution Name	(0008,0080)	1C/1	1C/1		<input checked="" type="checkbox"/>	<input type="checkbox"/>
>>Institution Address	(0008,0081)	3/3	3/3		<input checked="" type="checkbox"/>	<input type="checkbox"/>
>>Institution Code Sequence	(0008,0082)	1C/1	1C/1		<input checked="" type="checkbox"/>	<input type="checkbox"/>
>>>Code Value	(0008,0100)	1C/1 (Required if Sequence Item is present)	1C/1 (Required if Sequence Item is present)		<input checked="" type="checkbox"/>	<input type="checkbox"/>
>>>Coding Scheme Designator	(0008,0102)	1C/1 (Required if Sequence Item is present)	1C/1 (Required if Sequence Item is present)		<input checked="" type="checkbox"/>	<input type="checkbox"/>
>>>Code Meaning	(0008,0104)	3/3	3/3		<input checked="" type="checkbox"/>	<input type="checkbox"/>

Description / Module	Tag	Type N-CREATE SCU/SCP	Type N-SET SCU/SCP	Re- quire- ment Type Final State ¹	Supported by Windows® Edition	Supported by Unix Edition
>Protocol Name	(0018,1030)	1C/1 (Required if Sequence Item is pre- sent)	1C/1 (Required if Sequence Item is present)	1	<input checked="" type="checkbox"/>	<input type="checkbox"/>
>Operator's Name	(0008,1070)	3/3 ²	3/3 ²	2	<input checked="" type="checkbox"/>	<input type="checkbox"/>
>Operator Identification Sequence	(0008,1072)	3/3	3/3		<input checked="" type="checkbox"/>	<input type="checkbox"/>
>>Person Identification Code Sequence	(0040,1101)	1/1	1/1		<input checked="" type="checkbox"/>	<input type="checkbox"/>
>>>Code Value	(0008,0100)	1C/1 (Required if Sequence Item is pre- sent)	1C/1 (Required if Sequence Item is present)		<input checked="" type="checkbox"/>	<input type="checkbox"/>
>>>Coding Scheme Designator	(0008,0102)	1C/1 (Required if Sequence Item is pre- sent)	1C/1 (Required if Sequence Item is present)		<input checked="" type="checkbox"/>	<input type="checkbox"/>
>>>Code Meaning	(0008,0104)	3/3	3/3		<input checked="" type="checkbox"/>	<input type="checkbox"/>
>>Person's Address	(0040,1102)	3/3	3/3		<input checked="" type="checkbox"/>	<input type="checkbox"/>
>>Person's Telephone Numbers	(0040,1103)	3/3	3/3		<input checked="" type="checkbox"/>	<input type="checkbox"/>
>>Institution Name	(0008,0080)	1C/1	1C/1		<input checked="" type="checkbox"/>	<input type="checkbox"/>
>>Institution Address	(0008,0081)	3/3	3/3		<input checked="" type="checkbox"/>	<input type="checkbox"/>
>>Institution Code Sequen- ce	(0008,0082)	1C/1	1C/1		<input checked="" type="checkbox"/>	<input type="checkbox"/>
>>>Code Value	(0008,0100)	1C/1 (Required if Sequence Item is pre- sent)	1C/1 (Required if Sequence Item is present)		<input checked="" type="checkbox"/>	<input type="checkbox"/>

Description / Module	Tag	Type N-CREATE SCU/SCP	Type N-SET SCU/SCP	Re- quire- ment Type Final State ¹	Supported by Windows® Edition	Supported by Unix Edition
>>>Coding Scheme Designator	(0008,0102)	1C/1 (Required if Sequence Item is present)	1C/1 (Required if Sequence Item is present)		<input checked="" type="checkbox"/>	<input type="checkbox"/>
>>>Code Meaning	(0008,0104)	3/3	3/3		<input checked="" type="checkbox"/>	<input type="checkbox"/>
>Series Instance UID	(0020,000E)	1C/1 (Required if Sequence Item is present)	1C/1 (Required if Sequence Item is present)	1	<input checked="" type="checkbox"/>	<input type="checkbox"/>
>Series Description	(0008,103E)	3/3 ²	3/3 ²	2	<input checked="" type="checkbox"/>	<input type="checkbox"/>
>Retrieve AE Title	(0008,0054)	3/3 ²	3/3 ²	2	<input checked="" type="checkbox"/>	<input type="checkbox"/>
>Referenced Image Sequence	(0008,1140)	3/3 ²	3/3 ²	See F.7.2.2.2. (DICOM Standard)	<input checked="" type="checkbox"/>	<input type="checkbox"/>
>>Referenced SOP Class UID	(0008,1150)	1C/1 (Required if Sequence Item is present)	1C/1 (Required if Sequence Item is present)		<input checked="" type="checkbox"/>	<input type="checkbox"/>
>>Referenced SOP Instance UID	(0008,1155)	1C/1 (Required if Sequence Item is present)	1C/1 (Required if Sequence Item is present)		<input checked="" type="checkbox"/>	<input type="checkbox"/>
>Referenced Non-Image Composite SOP Instance Sequence	(0040,0220)	3/3 ²	3/3 ²	See F.7.2.2.2. (DICOM Standard)	<input checked="" type="checkbox"/>	<input type="checkbox"/>
>>Referenced SOP Class UID	(0008,1150)	1C/1 (Required if Sequence Item is present)	1C/1 (Required if Sequence Item is present)		<input checked="" type="checkbox"/>	<input type="checkbox"/>

Description / Module	Tag	Type N-CREATE SCU/SCP	Type N-SET SCU/SCP	Re- quire- ment Type Final State ¹	Supported by Windows® Edition	Supported by Unix Edition
>>Referenced SOP Instance UID	(0008,1155)	1C/1 (Required if Sequence Item is present)	1C/1 (Required if Sequence Item is present)		<input checked="" type="checkbox"/>	<input type="checkbox"/>
>All other attributes from Performed Series Sequence		3/3	3/3		<input checked="" type="checkbox"/>	<input type="checkbox"/>
All other attributes from Radiation Dose Module and Billing and Material Code Module		3/3	3/3		<input checked="" type="checkbox"/>	<input type="checkbox"/>

In the event of an successful N-CREATE and N-SET operation, MCPPS saves all UIDs identifying the received performed procedure step in the RIS and uses the Study Instance UID and the patient information for trying to build a link between the performed procedure step and a scheduled procedure step/study object in the RIS. The RIS may use these UIDs to move the images at a later time.

The SCP behaviour as a result of receiving the Performed Procedure Step information consists of storing the data assigned to the PPS SOP Instance in the RIS database. The PPS SOP Instance will remain in the RIS database – there is no deletion mechanism in place. After receiving a PPS SOP Instance with status COMPLETED or DISCONTINUED the corresponding SPS is flagged as completed or discontinued respectively.

MCPPS returns one of the following status codes to indicate an unsuccessful N-CREATE/N-SET:

Table 5-3 Reponse Codes

Response Code	Status	Further Meaning
0000	Success	Receiving and processing of PPS was successfully.
0111	Duplicate SOP Instance	The new managed SOP Value supplied by the invoking DIMSE-service-user was already registered for a managed SOP Instance of the specified SOP Class.
0106	Invalid Attribute value	The Attribute Value specified was out of range or otherwise inappropriate.
B102	Calling Error	Any other error during parsing message was encountered.
B101	Refused-Attribute empty	A required Attribute Value was empty (Type 1).
B100	Refused-Attribute miss-	A required Attribute was missing (Type 1 and 2).

	ing	
B200	Refused-Attribute not allowed	An Attribute was included in the message, which is not defined within Table F.7.2-1 of the DICOM Standard.
0110	Processing Failure	A general failure in processing the operation was encountered.
0112	No such SOP Instance	The SOP Instance was not recognized.

5.2.2.1.2.2 Presentation Context Acceptance Criterion

MCPPS (SCP) will always accept a Presentation Context for the Modality Performed Procedure SOP Class with the DICOM Default Transfer Syntax.

MCPPS (SCP) will accept any number of presentation contexts specified in Table 5-2 Acceptable Presentation Contexts for MCPPS. MCPPS will examine proposed Presentation contexts in the order proposed. For the presentation contexts of the same abstract syntax but different transfer syntaxes, only one of these presentation contexts will be accepted with the most preferred transfer syntax chosen by MCPPS. The policy of making this choice is described in the next section.

5.2.2.1.2.3 Transfer Syntax Selection Policy

MCPPS (SCP) selects the transfer syntax to accept for receiving a Performed Procedure Step with the following general rules: First of all, it prefers a transfer syntax which provides the explicit VR representation. After the VR choice has been made, MCPPS (SCP) tries to select the transfer syntax using following preference in descending order:

1. Explicit VR Little Endian
2. Explicit VR Big Endian
3. Implicit VR Little Endian

Different Transfer Syntaxes will not be selected.

5.2.3 Association Initiation Policy

MCPPS attempts to initiate a new association to a peer PPS SCP each time it receives a valid N-CREATE/N-SET message.

5.2.3.1 Real-World Activity MPPS SCU

5.2.3.1.1 Associated Real-World Activity

If MCPPS (SCP) receives a valid Modality Performed Procedure Step SOP instance MCPPS (SCU) forwards the information - if configured - to a third device.

5.2.3.1.2 Presentation Context Table

MCPPS (SCU) will propose the Presentation Contexts shown in Table 5-4.

Table 5-4 Proposed Presentation Contexts of MCPPS

Presentation Context Table					
Abstract Syntax		Transfer Syntax		Role	Extended Negotiation
Name	UID	Name	UID		

Modality Performed Procedure Step SOP Class	1.2.840.10008.3.1.2.3.3	DICOM Implicit VR Little Endian	1.2.840.10008.1.2	SCU	None
		DICOM Explicit VR Little Endian	1.2.840.10008.1.2.1		
		DICOM Explicit VR Big Endian	1.2.840.10008.1.2.2		

5.2.3.1.2.1 SOP Specific Conformance

MCPPS provides the Standard Conformance to the DICOM Modality Performed Procedure Step Service Class as an SCU (see 5.2.2.1.2.1). MCPPS does not provide extended negotiation. The SCU behaviour as a result of receiving the Performed Procedure Step information (by PPS-Manager SCP) consists of forwarding the data to a third device. In case the association could not be established or the response code from the third system is unequal Success (0000) the PPS information objects are queued and the PPS-Manager SCU attempts later to forward the information. This is repeated until the data could be forwarded successfully or the system administrator deletes the PPS object from the queue.

6 COMMUNICATION PROFILES

6.1 SUPPORTED COMMUNICATION STACKS

MedoraCOM provides DICOM TCP/IP Network Communication Support as defined in PS 3.8.

6.1.1 TCP/IP Stack

MedoraCOM inherits its TCP/IP stack from the base operating system upon which it executes.

6.1.2 Physical Media Support

MedoraCOM is indifferent to the physical medium over which TCP/IP executes. Support for the physical network medium is provided by the underlying base operating system.

7 CONFIGURATION

MedoraCOM Server (MCSR) and MedoraCOM PPSManager SCP (MCPSP) can be configured for the TCP/IP port number on which it will listen for incoming TCP/IP connections.

MedoraCOM Image Query/Retrieve Server (MCQRS) and MedoraCOM PPSManager SCU (MCPSC) can be configured for the TCP/IP port number on which it will try to connect to a remote AE.

8 SUPPORT OF EXTENDED CHARACTER SETS

MedoraCOM supports the ISO-IR 100 character set in addition to the default character repertoire.

9 CODES AND CONTROLLED TERMINOLOGY

All code sequences in the MWL response are configurable for the specific institution. The user is able to add and change these values using the Centricity RISi application. Thus the value for Coding Scheme Designator (0008,0102) is always 'L'.

10 SECURITY PROFILES

The product does not conform to any defined DICOM Security Profiles.

It is assumed that the product is used within a secured environment. It is assumed that a secured environment includes at a minimum:

1. Firewall or router protections to ensure that only approved external hosts have network access to the product.
2. Firewall or router protections to ensure that the product only has network access to approved external hosts and services.
3. Any communications with external hosts and services outside the locally secured environment use appropriate secure network channels (such as a Virtual Private Network (VPN))