

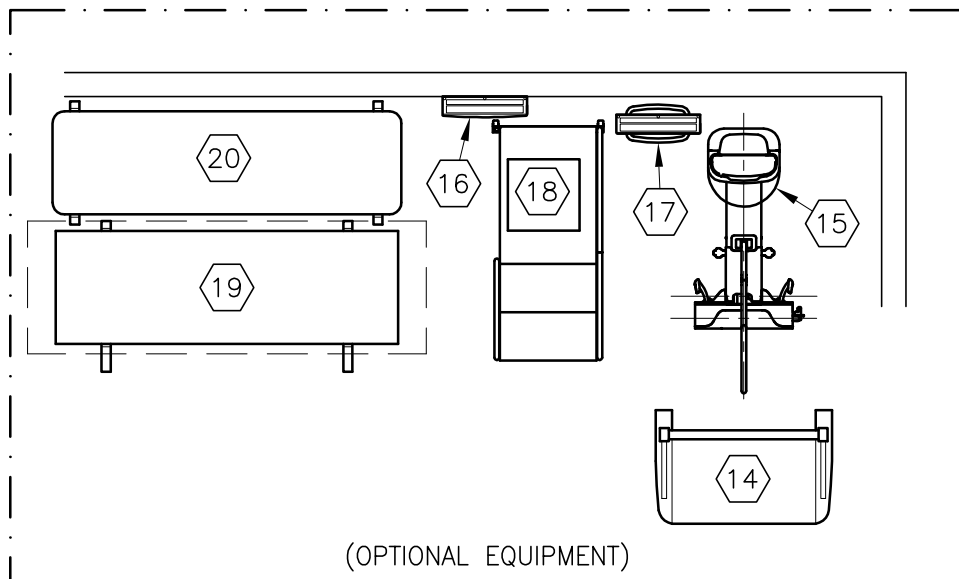

# DISCOVERY XR656 HD

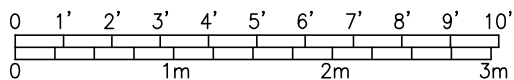

THE FOLLOWING SHOTS ARE NOT AVAILABLE IN THIS LAYOUT:  
 REAR TO FRONT CROSS TABLE SHOT TO TABLE CENTERLINE

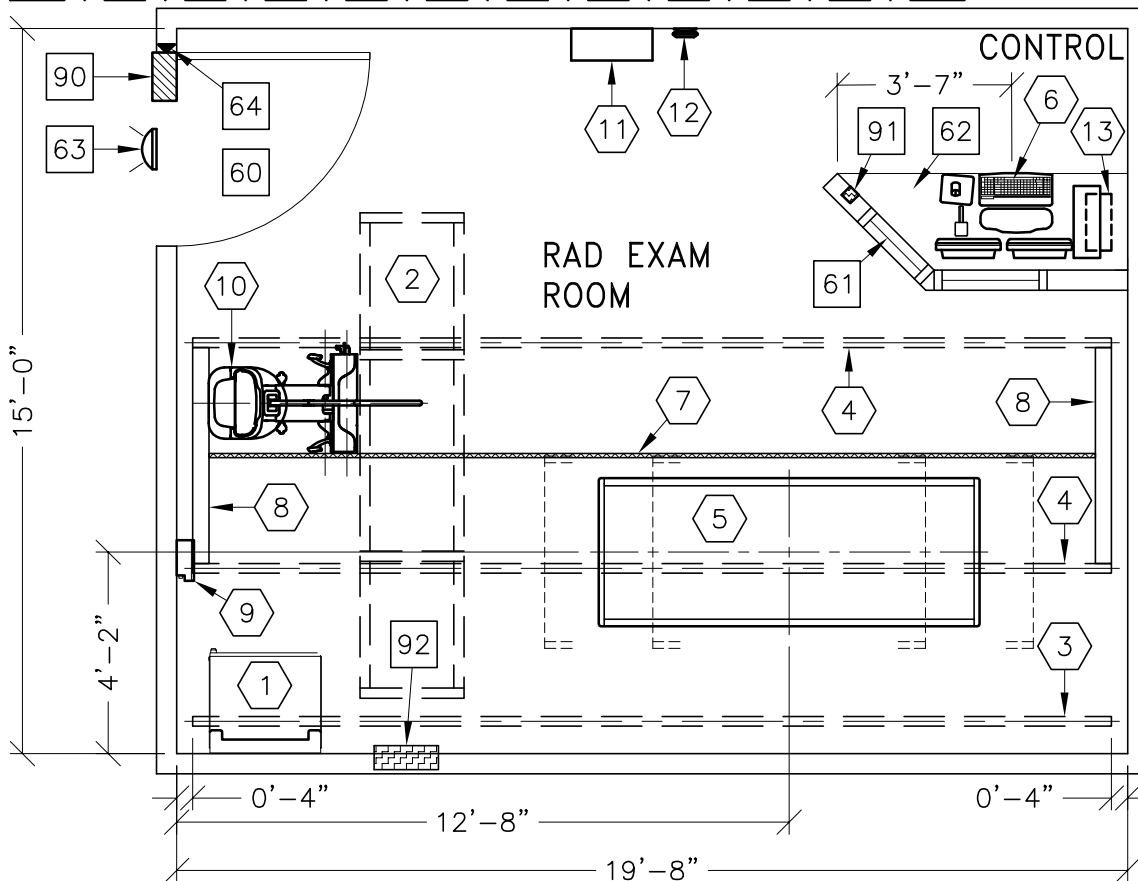

ROOM DIMENSIONS	LENGTH & WIDTH	CEILING HEIGHT
MINIMUM:	VARIABLES: BASED ON EQUIPMENT AND APPLICATIONS	8'-10" [2693mm]

ROOM PLAN LOCATED ON PAGE 1-168

ITEM	QUANTITY	ITEM DESCRIPTION	WEIGHT	HEAT OUTPUT
①	1	SYSTEM CABINET	705 lbs	2440 btu
②	1	XT RADIOGRAPHIC SUSPENSION WITH INBOARD MOUNTING.	787 lbs	501 btu
③	1	CABLE DRAPE RAIL.	180 lbs	
④	2	LONGITUDINAL STATIONARY RAIL FOR XT SUSPENSION	68 lbs	
⑤	1	XR656 G3 DIGITAL ELEVATING TABLE	838 lbs	372 btu
⑥	1	OPERATORS CONSOLE	79 lbs	604 btu
⑦	1	LONGITUDINAL DRIVE BELT 1 IN. WIDE	44 lbs	
⑧	2	ANCHOR RAILS		
⑨	1	TETHER INTERFACE BOX	15 lbs	10 btu
⑩	1	DIGITAL CHEST UNIT	595 lbs	136 btu
⑪	1	GRID HOLDER <FIELD VERIFY IDEAL LOCATION>	30 lbs	
⑫	1	ACCESS POINT	2 lbs	
— OPTIONAL —				
⑬	1	PARTIAL SYSTEM UNINTERRUPTIBLE POWER SUPPLY	77 lbs	30 btu
⑭	1	IMAGE PASTING BARRIER	121 lbs	
⑮	1	DIGITAL CHEST UNIT WITH EXTENDED RECEPTOR	642 lbs	136 btu
⑯	1	DETECTOR BIN <WALL MOUNT>	33 lbs	
⑰	1	DETECTOR BIN <FLOOR MOUNT>	33 lbs	
⑱	1	WEIGHT BEARING STAND	123 lbs	
⑲	1	MOBILE TABLE	224 lbs	
⑳	1	CARBON FIBER TABLE	70 lbs	

ENVIRONMENT

Ambient Operation Temperature: 59-95° <F> [15-35° <C>]  
 Allowable Temperature Change: <50° <F> [<10° <C>] per hour  
 Humidity: 30-60 percent non condensing  
 Allowable Humidity Change: <30 percent per hour  
 Max - Altitude: 9,842.52 FT. [3000 M]

ROOM PLAN LOCATED ON PAGE 1-168

ITEM	QUANTITY	ITEM DESCRIPTION	WEIGHT	HEAT OUTPUT
***** <b>CUSTOMER/CONTRACTOR SUPPLIED AND INSTALLED ITEMS</b> *****				
60		MINIMUM DOOR OPENING FOR EQUIPMENT DELIVERY IS 37.5 IN. W x 75 IN. H [950mm x 1900mm], CONTINGENT ON A 98.5 IN. [2500mm] CORRIDOR WIDTH NOTE: IMAGE PASTE OPTION REQUIRES AN 82 IN. H [2100mm] HIGH OPENING FOR ACCESS.		
61		CONTROL WALL, 7 FT. HIGH WITH LEAD GLASS VIEWING WINDOW.		
62		COUNTER TOP FOR EQUIPMENT-MINIMUM DEPTH 24 IN. AND ADDITIONAL SHELVING MAY BE REQUIRED BELOW COUNTER TOP FOR PC TOWER. PROVIDE GROMMETED OPENINGS AS REQUIRED TO ROUTE CABLES.		
63		X-RAY ON WARNING LIGHT - AVAILABLE FROM GE SUPPLY CALL: 800-200-9760 GE CAT. NO. WXIABWW-0F-XIU		
64		DOOR LIMIT SWITCH <NEEDED ONLY IF REQUIRED BY STATE/LOCAL CODES>		
90		X-RAY ROOM WARNING LIGHT CONTROL PANEL REFERENCE JUNCTION POINT 'XRLC' ON SHEET 'E1' FOR DETAILED DESCRIPTION -E4502RL FOR WARNING LIGHT CONTROL ONLY.		
91		EMERGENCY OFF SWITCH <NEEDED ONLY IF REQUIRED BY STATE/LOCAL CODES>		
92		MAIN DISCONNECT, REFERENCE JUNCTION POINT 'A' ON SHEET E1. <16" W x 24" H x 6" D>		