

Aestiva/5 anesthesia machine

More than superior ventilation

Features

Superior ventilation: 7900 SmartVent™

- Volume Mode, pressure
- Volume Mode, Pressure Control Mode, Pressure Support (PSVPro®), Synchronized Intermittent Mandatory Ventilation (SIMV), electronic PEEP
- Tidal volume compensation
- One motion from mechanical to manual mode
- Two key presses to total standby: end case
- Cardiac bypass case mode

Open systems architecture

- Lower overall height
- User configurable drawers/shelving

Innovative patient breathing system

- Eight machine hoses/cables integrated
- “No tools” disassembly of components
- Autoclavable and latex-free
- Responsive location of common gas outlet

Improved low flow/reduced life cycle costs

- Fresh gas flow compensation-automatically
- Smooth, faster acting fresh gas flow control
- Minimum O₂ flow of 50 mL
- Dual air flow tube for low flow
- Two scheduled maintenance checks per year



Aestiva®/5
Two vaporizer configuration



Aestiva/5
Three vaporizer configuration



Physical Specifications

Dimensions

	2 vaporizer configuration	3 vaporizer configuration
Height:	135.8 cm/ 53.4 in	135.8 cm/53.4 in
Width:	75 cm/29.5 in	93 cm/36.6 in
Depth:	83 cm/32.7 in	83 cm/32.7 in
Weight:	Approximately 136 kg/300 lb	Approximately 154 kg/340 lb

Top shelves (optional)

	2 vaporizer configuration	3 vaporizer configuration
Weight limit:	46 kg/100 lb	46 kg/100 lb
Width:	47.5, 67.5 or 87.5 cm/ 18.7, 26.6 or 34.4 in	87.5 or 67.5 cm/ 34.4 or 26.6 in
Depth:	41 cm/16.1 in	41 cm/16.1 in

Work surface

Height:	87.6 cm/34.5 in
Width:	47 cm/18.5 in
Depth:	31.5 cm/12.4 in

Folding side shelf (optional)

Height:	87.5 cm/34.5 in
Width:	26.5 cm/10.4 in
Depth:	31.5 cm/12.4 in
Weight limit:	11.3 kg/25 lb

DIN rail (optional)

Side of tabletop:	30 cm/12 in
Side of machine:	23.5 cm/9.25 in

Top drawer (1 standard)-locking (internal dimensions)

Height:	10.5 cm/4.1 in
Width:	38.5 cm/15.2 in
Depth:	26 cm/10.2 in

Lower drawers (optional)*

Height:	14.5 cm/5.7 in
Width:	38.5 cm/15.2 in
Depth:	26 cm/10.2 in

Lower shelves (optional)*

Heights:	9.2 cm/3.7 in	13.2 cm/5.2 in
	20.6 cm/8.2 in	24.6 cm/9.8 in
	28.6 cm/11.4 in	36 cm/14.4 in
Width:	42.5 cm/16.75 in	42.5 cm/16.75 in
Depth:	36 cm/14 in	36 cm/14 in

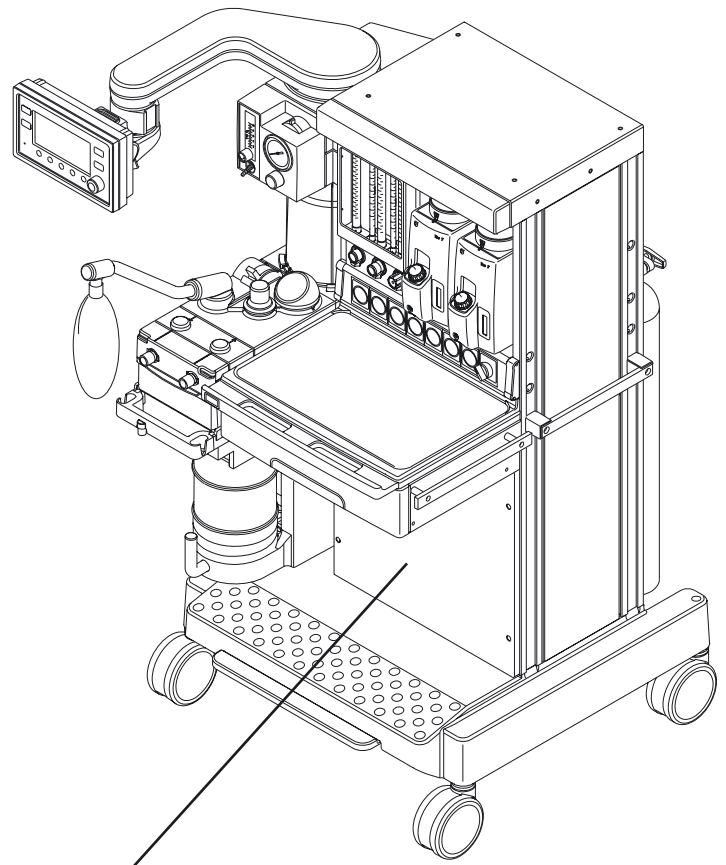

Space for additional shelves and drawers

* Lower cabinet can be configured with a variety of shelf and drawer combinations

Ventilator screen

Height: 7.6 cm/3 in
Width: 15.2 cm/6 in

Casters

Diameter: 12.5 cm/5 in
Brakes: Single foot lever locks and unlocks two front casters

Ventilator operating specifications

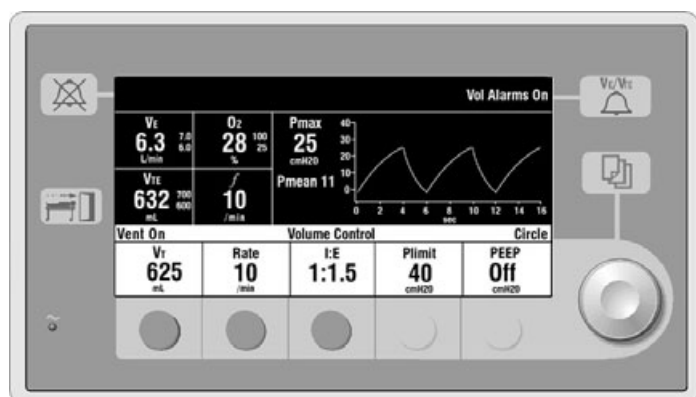

Ventilation operating modes

Volume Control

Pressure Control

Synchronized Intermittent Mandatory Ventilation (SIMV) – (optional)

Pressure Support (PSVPro) with Apnea Backup ventilation – (optional)

Ventilator (V_T) parameter ranges

Tidal volume range: 20 to 1500 mL (Volume Control and SIMV modes)

Incremental settings:
20 to 100 mL (increments of 5 mL)
100 to 300 mL (increments of 10 mL)
300 to 1000 mL (increments of 25 mL)
1000 to 1500 mL (increments of 50 mL)

Minute volume range: 0 to 99.9 L/min

Pressure ($P_{Inspired}$) range: 5 to 60 cm H₂O (increments of 1 cm H₂O)

Pressure (P_{limit}) range: 12 to 100 cm H₂O (increments of 1 cm H₂O)

Pressure ($P_{support}$) range: Off, 2 to 40 cm H₂O (increments of 1 cm H₂O)

Rate: 4 to 100 breaths per minute for Volume Control and Pressure Control; 2 to 60 breaths per minute for SIMV, PSVPro and SIMV-PC+PSV (increments of 1 breath per minute)

Inspiratory/expiratory ratio: 2:1 to 1:8 (increments of 0.5)

Inspiratory time: 0.2 to 5.0 seconds (increments of 0.1 seconds) (SIMV and PSV Pro)

Trigger window: 0 to 80% (increments of 5%)

Flow trigger: 0.2 to 1 L/min (increments of 0.2 L/min)
1 to 10 L/min (increments of 0.5 L/min)

Inspiration termination level: 5 to 75% (increments of 5%)

Backup mode delay: 10 to 30 seconds (increments of 5 seconds)

Positive End Expiratory Pressure (PEEP)

Type: Integrated, electronically controlled

Range: OFF, 4 to 30 cm H₂O (increments of 1 cm H₂O)

Ventilator performance

Pressure range at inlet: 240 kPa to 700 kPa/
35 psig to 100 psig

Peak gas flow: 120 L/min + fresh gas flow

Flow valve range: 1 to 120 L/min

Flow compensation range: 200 mL/min to 15 L/min

Ventilator monitoring

Expiratory minute volume range:	0 to 99.9 L/min
Expiratory tidal volume range:	0 to 9999 mL
O ₂ percent:	8 to 100%
Peak pressure:	-20 to 120 cm H ₂ O
Mean pressure:	-20 to 120 cm H ₂ O
Plateau pressure:	0 to 120 cm H ₂ O
Pressure waveform sweep speed:	4 to 25 breaths per minute (0 to 15 seconds) 26 to 75 breaths per minute (0 to 5 seconds) 75 breaths per minute (0 to 3 seconds)

Ventilator accuracy

Delivery/monitoring accuracy

Volume delivery:	> 210 mL = better than 7% < 210 mL = better than 15 mL < 60 mL = better than 10 mL
Pressure delivery:	±10% or ±3 cm H ₂ O
PEEP delivery:	±1.5 cm H ₂ O
Volume monitoring:	> 210 mL = better than 9% < 210 mL = better than 18 mL < 60 mL = better than 10 mL
Pressure monitoring:	±5% or ±2 cm H ₂ O

Alarm settings

Tidal volume (V _{TE}):	Low: OFF, 0 to 1500 mL High: 20 to 1600 mL, OFF
Minute volume (V _E):	Low: OFF, 0 to 10 L/min High: 0 to 30 L/min, OFF
Inspired oxygen (FiO ₂):	Low: 18 to 100% High: 18 to 100%, OFF
Apnea alarm:	<i>Mechanical ventilation ON:</i> < 5 mL breath measured in 30 seconds <i>Mechanical ventilation OFF:</i> < 5 mL breath measured in 30 seconds
Low airway pressure:	4 cm H ₂ O above PEEP
High pressure:	12 to 100 cm H ₂ O (increments of 1 cm H ₂ O)

Sustained airway pressure:	<i>Mechanical ventilation ON:</i> P _{limit} < 30 cm H ₂ O, the sustained limit is 6 cm H ₂ O P _{limit} 30 to 60 cm H ₂ O, the sustained limit is 20% of P _{limit} P _{limit} > 60 cm H ₂ O, the sustained limit is 12 cm H ₂ O <i>PEEP and mechanical ventilation ON:</i> Sustained limit increases by PEEP minus 2 cm H ₂ O <i>Mechanical ventilation OFF:</i> P _{limit} ≤ 60 cm H ₂ O, the sustained limit is 50% of P _{limit} P _{limit} > 60 cm H ₂ O, the sustained limit is 30 cm H ₂ O
Subatmospheric pressure:	Paw < -10 cm H ₂ O

Alarm silence countdown timer:	120 to 0 seconds
--------------------------------	------------------

Ventilator components

Flow transducer

Type:	Variable orifice flow sensor
Dimensions:	22 mm OD and 15 mm ID
Location:	Inspiratory outlet and expiratory inlet
Optional autoclavable sensor available	

Oxygen sensor

Type:	Galvanic fuel cell
Life cycle:	Approximately 18 months (dependent on usage)

Anesthetic agent delivery

Vaporizers:	Tec 4, Tec 5, Tec 6 Plus, Tec 7
Number of positions:	2 or 3
Mounting:	Tool-free installation Selectatec® manifold interlocks and isolates vaporizers



Tec 6 Plus

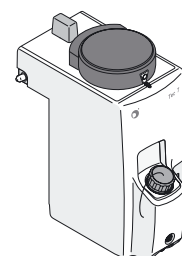

Tec 7

Electrical specifications

Current leakage

120 V:	< 300µA
220 V:	< 500µA

Light package

Task light:	12 V, 3 lamps, type 194, .270A each
Goose neck (optional):	12 V, type 1815, .200A

Power and battery backup

Power input: <i>USA/Canada/</i>	
<i>Mexico:</i>	120 Vac, 60 Hz, 10A
<i>Euro:</i>	220-240 Vac, 50 Hz, 6A
<i>France/</i>	
<i>Belgium:</i>	230 Vac, 50 Hz, 6A
<i>Japan:</i>	100 Vac, 50 or 60 Hz, 10A
<i>UK:</i>	240 Vac, 50 Hz, 6A
Backup power:	Demonstrated battery backup time under typical operating conditions is 45 minutes when fully charged
Battery type:	Internal rechargeable sealed lead acid
Power cord: <i>Length:</i>	5 m/16.4 ft
<i>Rating:</i>	10A @ 250 Vac or 15A @ 120 Vac

Communication port

Serial interface:	Isolated RS-232C compatible port
-------------------	----------------------------------

Inlet/outlet modules

	220-240 V	120 V	100 V
System circuit breakers:	<i>No outlets 3A w/outlets 6A</i>	<i>No outlets 5A w/outlets 10A</i>	<i>No outlets 5A w/ outlets 10A</i>
Outlets (optional):	4 outlets on back, 3-1A, 1-2A individual breakers and 1-3A combined outlet breaker, optional isolation transformer	4 outlets on back, 3-2A, 1-3A individual breakers and 1-5A combined outlet breaker, optional isolation transformer	3 outlets on back, 2-2A, 1-4A individual breakers and 1-5A combined outlet breaker, optional isolation transformer
Auxiliary outlet box (optional):	5 CEE 7/7 outlets on dovetail-mounted box, 5-2A breakers, isolation transformer	5 NEMA outlets on dovetail-mounted box, 5-2A breakers, isolation transformer	
Tec 6 Plus outlet:	1 IEC 320 located above vaporizer backbar		

Pneumatic specifications

Internal common gas outlet

Connector: ISO 22 mm OD and 15 mm ID

Auxiliary common gas outlet (optional)

Connector: ISO 22 mm OD and 15 mm ID

Gas supply

Pipeline input range: 240 kPa to 600 kPa/
35 psig to 88 psig

Pipeline connections: DISS-male, DISS-female,
DIN 13252, AS4059, F90-116,
PrEN737-6, or NIST (ISO 5359)
All fittings available for O₂, N₂O,
and Air, and contain pipeline
filter and check valve.

Cylinder input: Pin indexed in accordance with
CGA-V-1 or DIN (nut and gland);
contains input filter and check
valve

Note: Maximum 5 cylinders
total; one oxygen required.

Primary regulator
diaphragm minimum
burst pressure: 2758 kPa/400 psig

Primary regulator
nominal output: < 338 kPa/49 psig
Pin indexed cylinder connections

Gas power outlet (optional)

Connector: DISS indexed in accordance
with CGA-V-5

Gas: Oxygen

Pressure and flow
characteristics: Varies with source

O₂ controls

Method: Proportionate decrease of N₂O,
CO₂, O₂/He with reduction in
O₂ pressure

Supply failure alarm: Range: 193 kPa to 221 kPa/
28 psig to 32 psig

Sounds at maximum volume
every 10 seconds

O₂ flush: Range: 35 to 50 L/min

Flowmeters

O₂ ranges: Two tubes: 0.05 to 0.95 L/min
and 1 to 15 L/min

Minimum O₂ flow:
50 mL/min ±25 mL

N₂O ranges: Two tubes: 0 to 0.95 L/min
and 1 to 10 L/min

Air range: One tube option: 1 to 15 L/min

Two tube option:
0 to 0.95 and 1 to 15 L/min
(low flow tube optional)

CO₂ (optional): One tube: 0 to 0.5 L/min

Heliox range (optional): One tube: 0 to 15 L/min

Calibration:

Percent of full scale flow	Accuracy (% of flowrate)
100	±2.5%
90	±2.5%
80	±2.6%
70	±2.7%
60	±2.9%
50	±3.1%
40	±3.4%
30	±4.0%
20	±5.0%
10	±8.1%

Calibration conditions:* 20°C/68°F
101.3 kPa/760 mmHg

* Different breathing circuit pressures, barometric pressures or
temperatures change flowtube accuracy.

Hypoxic guard system

Type: Mechanical Link-25™

Range: Provides a nominal 25%
concentration of oxygen in any
O₂/N₂O mixture

Materials

All materials in contact with patient gas are free of natural
rubber latex.

Environmental specifications

System operation

Temperature:	10° to 40°C/50° to 104°F
Humidity:	15 to 95% relative humidity (non-condensing)
Altitude:	-440 to 3565 m/500 to 800 mmHg
System storage temperature:	-25° to 65°C/-13° to 149°F
Humidity:	10 to 100% relative humidity (including condensing)
Altitude:	-440 to 5860 m/375 to 800 mmHg
Oxygen cell storage:	-15° to 50°C/5° to 122°F 10 to 95% relative humidity 500 to 800 mmHg

Electromagnetic compatibility

Immunity:	Complies with all requirements of EN 60601-1-2
Emissions:	CISPR 11 group 1 class B
Approvals:	UL 2601-1, CSA C22.2 #601.1 IEC 601-1 EN 60601-1

Breathing circuit specifications

Operational modes

Breathing circuit modules: Interchangeable circle or bain (Mapleson D)

Carbon dioxide absorbent canisters (2)

Absorbent capacity:	1.35 kg/3 lb each
Canister release:	Integrated sensing mechanism CO ₂ bypass capability (optional)

Ports and connectors

Exhalation:	22 mm OD ISO 15 mm ID taper
Inhalation:	22 mm OD ISO 15 mm ID taper
Bag port:	22 mm OD

Pressure gauge

Scale range:	0 to 10 kPa/-20 to 100 cm H ₂ O
--------------	--

Bag-to-Ventilator switch

Type:	Bi-stable
Control:	Controls ventilator and direction of breathing gas within the circuit

Integrated Adjustable Pressure Limiting (APL) valve

Range:	0.8 to 70 cm H ₂ O
Tactile knob indication at:	30 cm H ₂ O and above
Adjustment range of rotation:	0.8 to 30 cm H ₂ O (0-230°) 30 to 70 cm H ₂ O (230-330°)

Materials

All materials in contact with exhaled patient gases are autoclavable, except standard flow sensors. (Autoclavable sensors optional)

All materials in contact with patient gas are free of natural rubber latex.

Breathing circuit parameters

Compliance: Bag mode:	5.15 mL/cm H ₂ O	
Mechanical mode:	Automatically compensates for compression losses within the absorber and bellows assembly	
Circuit volume:	5.5 L	
Expiratory resistance:	P_{insp}	P_{exp}
	Flow rate	Pressure drop
	10 L/min	0.74 cm H ₂ O 1.00 cm H ₂ O
	30 L/min	2.32 cm H ₂ O 2.36 cm H ₂ O
	60 L/min	5.93 cm H ₂ O 5.26 cm H ₂ O

Anesthetic gas scavenging

Type	Market	Hospital system required	Machine connection
Active low flow:	US and others	High vacuum 36 L/min (300 mmHg) @ 12 in Hg	DISS evac
Active low flow without flow indicator:	Japan	Adjustable Venturi with flowmeter > 30 L/min	12.7 mm/ 0.5 in hose barb
Active high flow:	UK/related	Low vacuum 40-130 L/min	30 mm/1.2 in BSI Male threaded
Passive:	Generic	Passive or externally attached active system	30 mm/1.2 in M ISO taper
Passive:	Sweden Norway	Venturi/Ejector > 30 L/min	12 mm/0.47 in hose barb
Passive:	Denmark	Venturi/Ejector > 30 L/min	8 mm/0.31 in hose barb

GE Healthcare
P.O. Box 7550
Madison, WI 53707-7550
USA

www.gehealthcare.com

GE Healthcare
P.O. Box 900, FIN-00031 GE, Finland
Tel. +358 10 394 11
Fax +358 9 146 3310

www.gehealthcare.com

© 2005 General Electric Company – All rights reserved.
GE and GE Monogram are trademarks of
General Electric Company.

Aestiva, Tec, PSVPro and Mechanical Link-25 are
trademarks of Datex-Ohmeda, Inc.

Datex-Ohmeda, Inc., a General Electric company,
going to market as GE Healthcare.



imagination at work